

**THE EFFECTS OF OSCILLATOR DISCHARGE CURRENT VARIATIONS
ON MAXIMUM DUTY CYCLE AND FREQUENCY
IN UC3842 AND UC3842-"A" PWM ICs**

by YEAM CHONG HOCK

Many designers try to program a precise maximum duty cycle and operating frequency by careful selection of the oscillator timing components, R_t and C_t . Because of the variations in oscillator discharge current, very accurate programming is not easily obtainable. However, it is possible with ICs which contain a "trimmed" discharge current which has specified limits. This Design Note will detail programming frequency and maximum duty cycle with both types of oscillators. Simplified equations will be used to develop obtainable ranges for these parameters over IC tolerances.

ON-TIME

Maximum on-time directly corresponds to the maximum charging time of the timing capacitor. Charging time (T_C) is determined by the timing capacitor

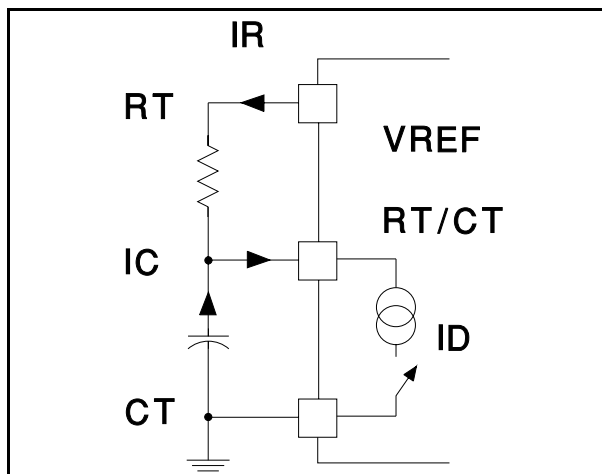

Figure 1: Basic UC3842 Oscillator Circuit

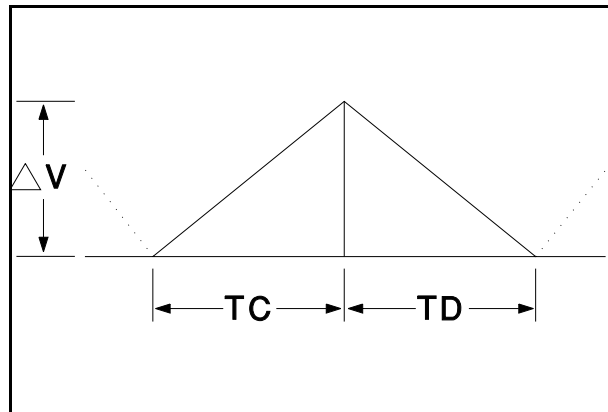

Figure 2: Timing Waveforms and Design Equations

value (C_t), the charging current (I_{Rt}) and the voltage amplitude between the upper and lower oscillator thresholds.

OFF-TIME (DEADTIME)

The off-time occurs while the timing capacitor is discharged from the oscillator upper threshold to its lower threshold. The discharge current actually sinks two currents to ground. One current is flowing from the discharging timing capacitor. Another current flows from the timing resistor (R_t) pulling to V_{ref} . Therefore, the effective timing capacitor discharge current (I_{Ct}) is the ICs discharge current (I_d) minus the timing resistor charging current (I_{Rt}). Maximum duty cycle and switching frequency can

be controlled by accurately setting the ratio of these currents and capacitor value. The related equations are listed below.

CHARGING:

$$ICt = C \times \frac{dV}{Tc} \quad ICt = C \times dV / Tc$$

$$ICt = \frac{5V}{Rt} \text{ (approximation)}$$

$$TC = c \times \frac{dV}{IRt}$$

DISCHARGING:

$$ICt = Id - IRt$$

$$Td = c \times \frac{dv}{(IRt - Id)}$$

$$Td = \frac{(Id - IRt)}{Id}$$

DUTY CYCLE:

$$D = \frac{Tc}{(Tc + Td)}$$

$$D = \frac{(Id - IRt)}{Id}$$

SWITCHING FREQUENCY:

$$F = \frac{1}{Tper} = \frac{1}{(Tc + Td)}$$

$$F = \frac{(Id - IRt)}{(Id \times Tc)}$$

EXAMPLE 1:

This example will calculate the potential variations in maximum duty cycle and frequency using a standard UC3842 device. A ten milliamp internal discharge current (Id = 10mA) will be used for initial programming. The worst case limits of 6 and 14 milliamp discharge currents will be used to analyze the possible variations. A target of 100kHz at 60% duty cycle will be used.

$$Id = 10mA \text{ (typical)}$$

$$Id (\text{min}) = 6mA, Id (\text{max}) = 14mA$$

$$F (\text{typ}) = 100kHz$$

$$D = 0.60 \text{ (60%)}$$

Based on the 10mA discharging current and the equations previously mentioned;

$$IRt = 4mA, \text{ and } Tc = 6\mu s$$

Using the same Rt and Ct values with a discharge current of 6mA results in:

$$Dmax = 0.33 \text{ (30%)}$$

$$F = 55kHz$$

When the highest discharge current of 14mA is used, the results are:

$$Dmax = 0.71 \text{ (71%)}$$

$$F = 118kHz$$

Therefore, the total possible range due to discharge current variations in maximum duty cycle and frequency is:

$$Dmax = 33 \text{ 71 percent}$$

$$Frequency = 55 \text{ 118kHz}$$

In most applications this range is far too wide to use in a high volume production environment. One technique to minimize the effects of the discharge current is to have the ICs sorted into different groups. Each group can have a tight distribution or tolerance and will use a specific timing resistor and capacitor to achieve the desired frequency and duty cycle. Each other group will also need a specific Rt and Ct for that group. Keeping these groups separated can create problems in some production situations. One alternative is to have the ICs measured and "binned" at the factory. Another way is to use only ICs within one distribution group, for example, 10mA +/- 1mA. Listed below is a general procedure to follow with grouped parts.

1. Sort ICs by discharge current range
ex: 7mA +/- 1mA (6-8mA total)
2. Select Rt and Ct using previous equations and worst case conditions.

Table 1 shows the results of selecting ICs by discharge current. The oscillator was programmed not to exceed 100kHz and 60% maximum duty cycle.

I Discharge (+/- 1mA)	Rt (k)	Ct (nF)	Minimum Duty%	Maximum Duty%	Minimum Freq (kHz)	Maximum Freq (kHz)
7mA	1.56	11.3	47	60	77.8	100
9mA	1.25	14.1	50	60	83.3	100
11mA	1.04	16.9	52	60	86.7	100

TRIMMED DISCHARGE CURRENT:

Very repeatable and predictable high volume production can be rescued from these variations by using the right IC, one with a trimmed discharge current. The UC3842A, UC3843A, UC3844A and UC3845A devices have an internal factory trimmed discharge current with a tight distribution. This is set at 8.3mA typically, and can only vary between a low of 7.5mA and a high of 8.8mA. Programming these ICs for a 50% maximum duty cycle and 100kHz switching frequency will result in worst case variations of:

$$D(\text{min}) = 56\%$$

$$D(\text{max}) = 62\%$$

$$F(\text{min}) = 92.9\text{kHz}$$

$$F(\text{max}) = 103.8\text{kHz}$$

This is a significant improvement over the non "A" version devices. The accuracy of these ICs will improve when these ICs are used at wider maximum duty cycles, for example 65 to 85 percent. The UC3844A and UC3845A are intended for 50% maximum duty cycle applications and contain a flip flop to insure that 50% D(max) is never exceeded. The UC3842A and UC3843A have maximum duty cycles near 100% and can be adjusted lower using the appropriate Rt and Ct components.