

**UC2577 Controls SEPIC Converter  
for Automotive Applications**

by Jack Palczynski

The Single Ended Primary Inductance Converter (SEPIC) can convert an input voltage to an output voltage that is higher, lower or equal to the input. Conversion is performed without the use of expensive transformers, making this a good choice for low cost, non-isolated applications. The UC2577 provides the switch and control to take advantage of this topology with a minimum of additional parts.

The circuit shown in Figure 1 was designed to provide a 5V or 12V output from an input voltage ranging between 3V and 40V. The coupling capacitor is chosen to handle the high ripple current seen in this topology, with a peak-to-peak current of approxi-

mately  $I_{IN} + I_{OUT}$ . The converter switches at 52kHz and operates in both continuous inductor current mode (CCM) and discontinuous inductor current mode (DCM). Note that both the diode and the switch have a peak voltage stress of approximately  $V_{IN} + V_{OUT}$ , and peak current stress of approximately  $I_{IN} + I_{OUT}$ . Note that when the converter is in CCM, the ratio of  $V_{OUT}/V_{IN} = D/(1-D)$  where D is the duty ratio. To calculate components for other inputs and outputs, assume CCM as a starting point and use about 1/2 max output current as a min value. For further details, consult Unitrode Design Note DN-48.

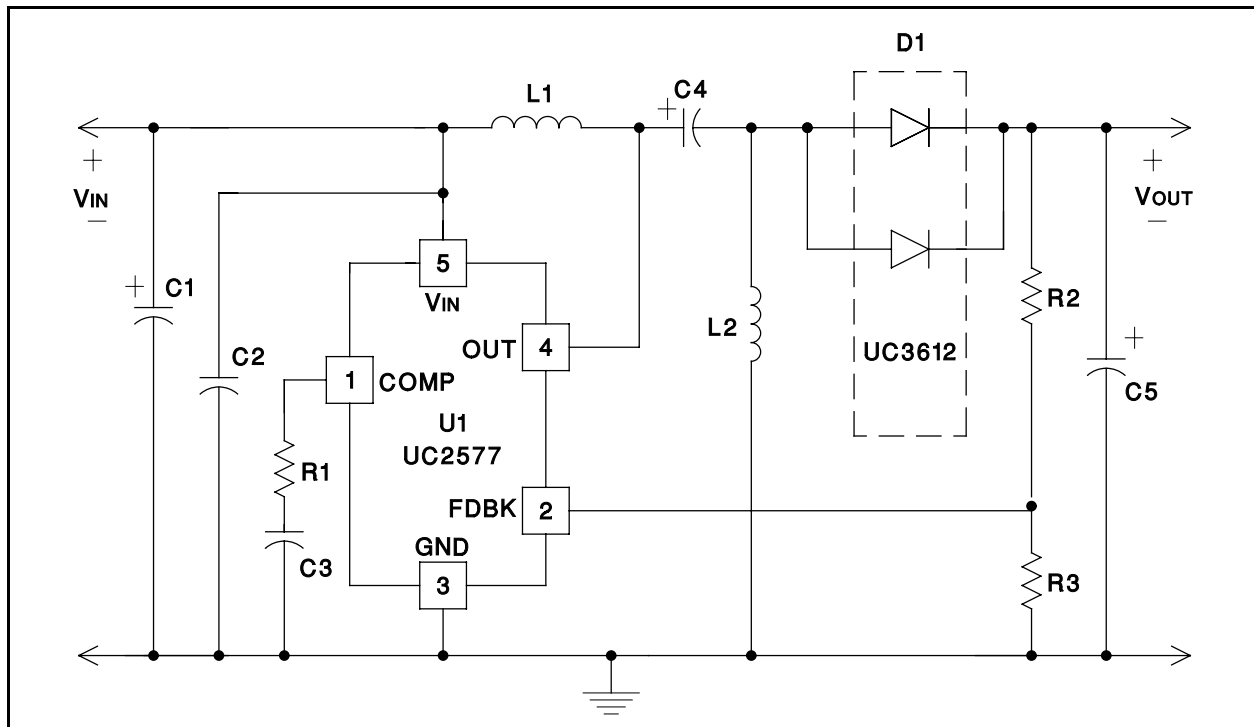
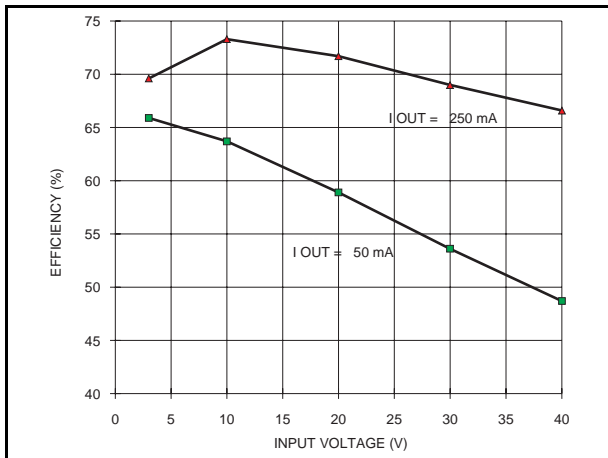


Figure 1. Easy SEPIC Converter Schematic

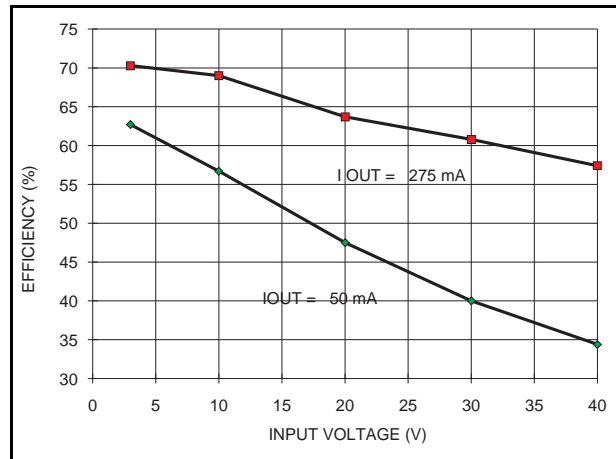
**Parts List:**

- U1 UC2577
- D1 UC3612 Dual Schottky
- L1,L2 100μH ECI # M1088  
phone (413) 562-7684
- C1 47μF/50V Sprague 515D476M050AA6A  
phone (207) 324-4140
- C2 0.1μF ceramic
- C3 0.47μF ceramic
- C4 220μF/50V Sprague 515D227M050CD6A
- C5 220μF/6V Sprague 595D227X9006D7  
(5V output)
- \* C5 12V output only, use four 68μF/16V  
Sprague 293D686X0016D2T
- R1 100 ohm 1/8W
- R2 3.01k 1/8W
- R3 1k 1/8W (5V output)
- \* R3 330 ohms 1/8W (12V output)
- \* D2,3 UC3612 Dual Schottky  
(Extended Operating Range)

Efficiency was measured for the 5V (Figure 2) and 12V (Figure 3) output at two power levels for the full range of Automotive input voltages.

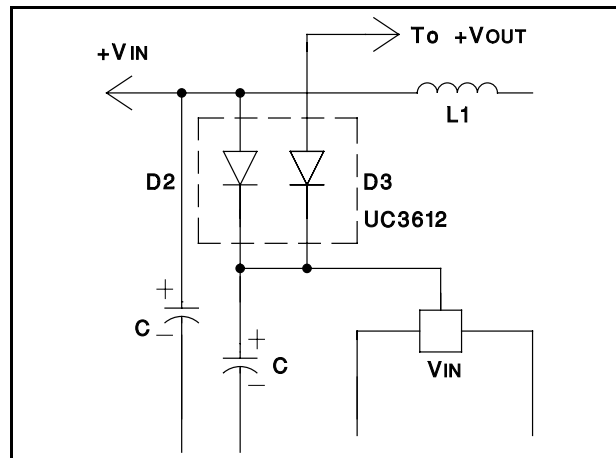


**Figure 2: 5V Converter Efficiency vs Input Voltage**



**Figure 3: 12V Converter Efficiency vs Input Voltage**

As seen in Figure one, a simple design is used to convert power for automotive applications. If longer hold up times are needed or operation at low input voltages demanded, the circuit in Figure 4 may become useful. By adding two diodes, the output voltage bootstraps the IC and allows operation even after the input voltage drops below the operating range of the IC.



**Figure 4: Extending Operation Range**