

Programming the UCC3806 Features

by Jack Palczynski

INTRODUCTION

The UCC3806 is a pin for pin compatible BiCMOS replacement for the UC3846 and UC3856. Some functions in the UCC3806 are programmed differently and these methods are explained here. In particular, the CUR LIM ADJ pin programs the maximum peak current for the current sense amplifier. This function is completely compatible with previous ICs. The second function on this pin is the latch/non-latch feature for the shutdown pin. Programming latch or non-latch mode differs from the UC3846 and UC3856 and these changes will be explained here.

Current Limit Adjust

To review, the CUR LIM ADJ pin adjusts the maximum current peak on the current sense amplifier (pin 4 to 3) by the formula: $V_{cl} = 1/3 * [(R2 * V_{REF}) / (R1 + R2) - 0.5]$. This can be verified by carefully following the path from the current sense amplifier to the CUR LIM ADJ pin. A second function is for shutdown mode programming. When the shutdown pin voltage exceeds 1V, the UCC3806 outputs shut down. At this point, a 190µA (typ) current sink pulls current from the CUR LIM ADJ pin to ground. If the voltage at the CUR LIM ADJ is above

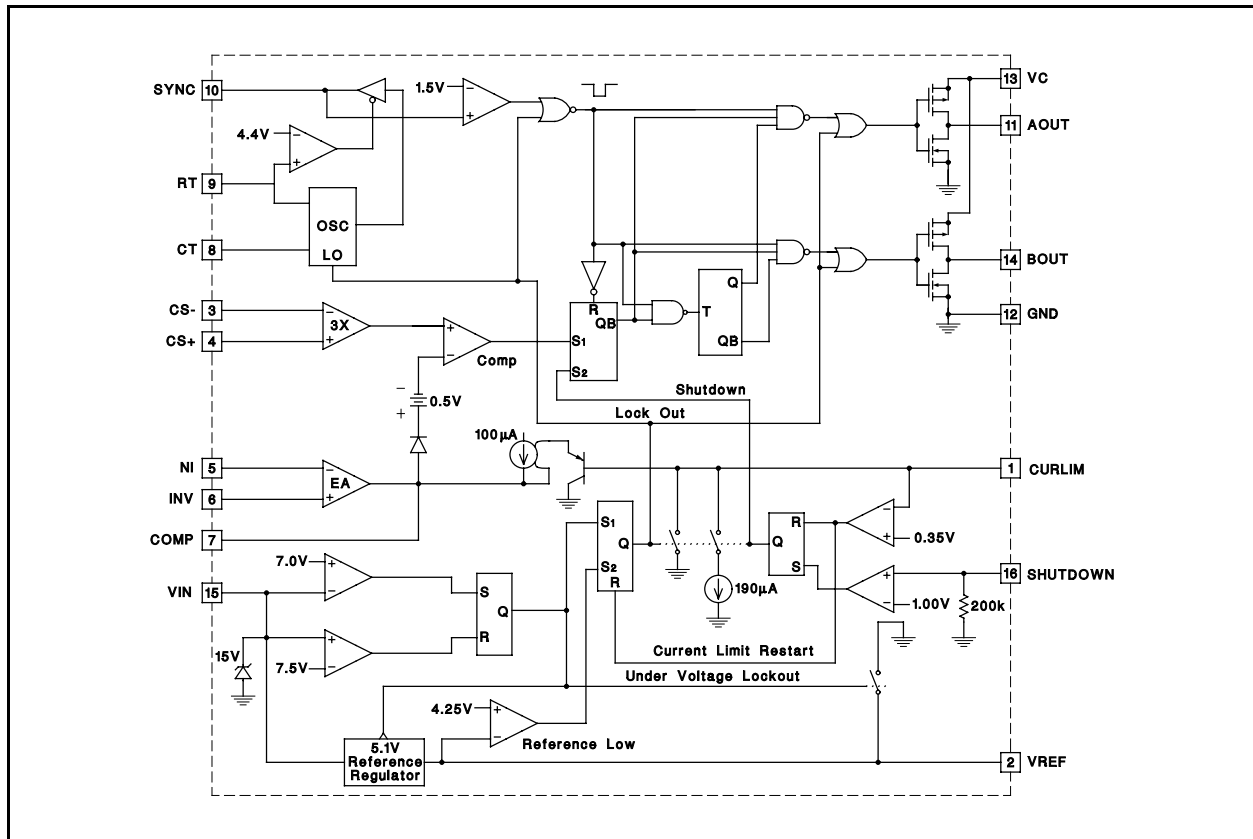

Figure 1: UCC3806 BiCMOS Current Mode PWM Block Diagram

350mV (typ), then the IC remains latched off. If this voltage falls below 350mV at any time, the shutdown is unlatched and the IC restarts. Calculating the actual voltage on the CUR LIM ADJ pin is a simple, two source superposition problem.

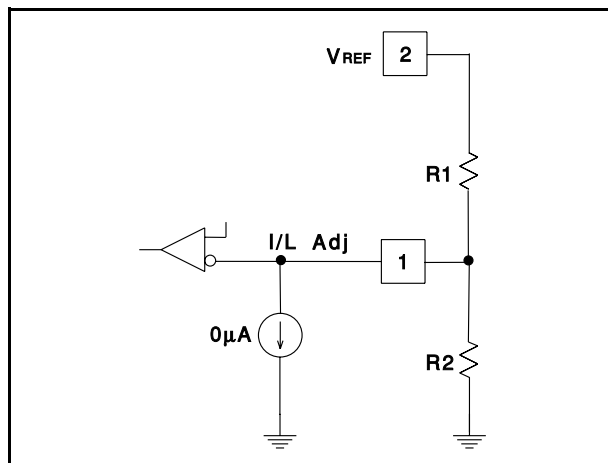

Figure 2: Superposition with current sink = 0

$$V = (V_{REF} \cdot R_2) / (R_1 + R_2)$$

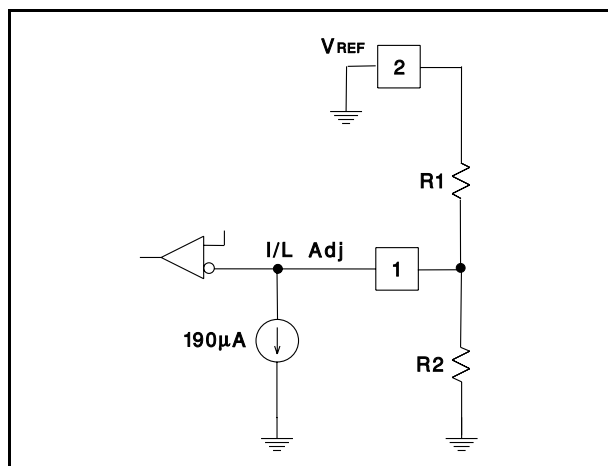

Figure 3: Superposition with VREF = 0

$$V = [-190\mu A \cdot (R_1 \cdot R_2)] / (R_1 + R_2)$$

Combining equations:

$$V = (V_{REF} - R_1 \cdot 190\mu A) / [1 + R_1/R_2]$$

The internal current sink is specified to be between 80µA to 300µA. This is the dominant source for error for this application, thus worst case values are

inserted into the above equation to determine latch and non-latch modes.

I LIM ADJ Latching Mode Voltage:

$$V = (V_{REF} - R_1 \cdot 300\mu A) / [1 + R_1/R_2] > 350mV$$

I LIM ADJ Non-Latching Mode Voltage:

$$V = (V_{REF} - R_1 \cdot 80\mu A) / [1 + R_1/R_2] < 350mV$$

Solving either of these equations and solving the equation for a desired current limit pin voltage simultaneously gives closed form solutions for R1 and R2. Some solutions are shown below.

Table of Approximate Resistor Value:

Latching Mode:			
V (pin 4)	R1	R2	V (pin 1)
1.0	16.5k	38.3k	0.1
0.77	15k	18.2k	0.3
0.5	14.7k	9.76k	0.3

Non-Latching Mode:			
V (pin 4)	R1	R2	V (pin 1)
1.0	54.9k	130k	0.5
0.77	54.9k	66.5k	0.4
0.5	51.1k	34k	0.4

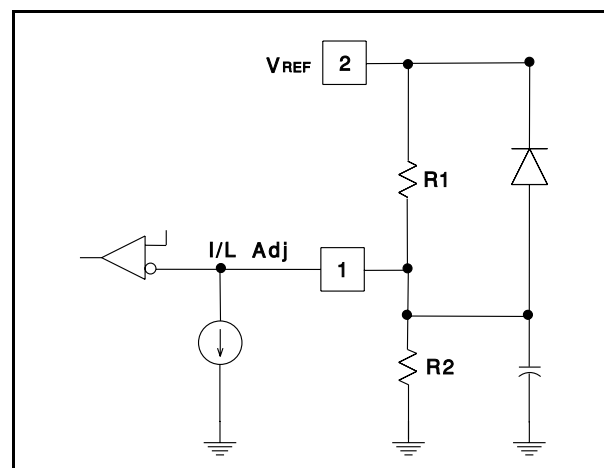

Figure 4: Soft starting the current

Softstart

The CUR LIM ADJ may also be used as a convenient soft start point. By adding a capacitor across R2, maximum current sense ramps up as the soft start capacitor charges. A diode may be added to force a quick discharge of the capacitor when IC power is removed.

SUMMARY

With a systematic approach, one may achieve a variety of maximum current peak levels and the desired shutdown mode. In addition, the UCC3806 allows for a programmed softstart by adding a capacitor to the CUR LIM ADJ pin. By understanding the internal workings of the UCC3806, designers

will find many features which can be of great help in reducing parts count and current requirements.

REFERENCES

- (1) W. Andreyca, "UCC3800/1/2/3/4/5 BiCMOS Current Mode Control ICs" Unitrode Integrated Circuits Corporation U-133, Unitrode Product & Applications Handbook '93-'94, pp. 9-344 to 9-361.
- (2) J. Palczynski, "UCC BiCMOS Current Mode Control IC" Unitrode Integrated Circuits Corporation Applications Note U-144.
- (3) W. Andreyca, "Practical Considerations in Current Mode Power Supplies" Unitrode Integrated Circuits Applications Note U-111, Unitrode Product & Applications Handbook '93-'94, pp. 9-134 to 9-151.