

Considerations in Powering BiCMOS ICs

by Jack Palczynski

Bipolar linear integrated circuits have been with us for years in the form of PWM and PFC controllers, supervisory circuits and others. Since these devices have traditionally been built using relatively high voltage (35V) Bipolar processes, powering considerations were typically never a concern. In addition, many of these ICs contained high current protection zeners to keep higher voltages from damaging the device. With a number of new BiCMOS ICs now replacing traditional Bipolars, more consideration needs to be given to powering these low voltage controllers. This Design Note will provide more details regarding the device specifications and help simplify the powering and use of these energy saving devices.

The most prolific of PWM ICs are those of the UC3842 family which are easy to use and to power. The VCC supply can be as high as 34V and an on-chip zener can sink up to 30mA of current. It consumes significantly more power in comparison to the replacement series of Unitrode UCC3802 BiCMOS PWMs. Requiring only about 10% of the current used by the UC3842, these BiCMOS parts are a logical replacement for previous UC3842 based designs. The tradeoff is that the maximum voltage is 13.5V. With these specifications in mind, several power methodologies will be described.

Upon first review of the UCC3802 data sheet, several seemingly contradictory specifications could be noted. The UVLO start threshold has a range of 11.5V to 13.5V, while the protection zener voltage can vary from 12.0V to 15.0V. However, the absolute maximum supply voltage of the IC is specified at 12.0V. This absolute maximum is defined as the lowest possible zener voltage when driven from a low impedance (voltage) source. Note, however, that the zener volt-

age is always higher than the UVLO start voltage. These two parameters track each other and the chip is tested to guarantee that the zener voltage will never be below that of the start voltage.

For low cost, off-line applications, these newly introduced control ICs offer savings in overall cost and power in comparison to their predecessors. For example, the UCC3802 PWM consumes only 1mA (approximate) for full operation – which can eliminate the need for a bias supply in many instances. To this 1mA, add estimates for the other currents consumed by the control circuitry (gate drive, slope compensation, etc.). Working backwards, calculate the resistor value for the circuit of Figure 1 to deliver this current from the rectified, filtered line voltage. Typically, the AC input voltage will range from 85VRMS to 264VRMS, or about a 3:1 ratio. The corresponding DC input will vary accordingly from 124VDC to 374VDC. Calculate R1 to provide supply current at the lowest input voltage. 3mA minimum supply current is used for this example.

$$\frac{124\text{VDC} - 12\text{VDC}}{3\text{mA}} = 37.3\text{k}\Omega \text{ (use } 36\text{k)}.$$

At high line, this current will increase to

$$\frac{374\text{VDC} - 12\text{VDC}}{36\text{k}} = 10.1\text{mA}$$

and dissipate more power. The resistor will guarantee that the ICs zener clamp will not be subjected to overcurrent since it shunts only 7.1mA, the other 3mA are consumed for operation. This configuration is generally referred to as a "current source" power supply. Before the IC starts, it only draws 100µA and C1 is charged with nearly the full supply current. Once C1 reaches the UVLO start threshold of about 13.5V, the

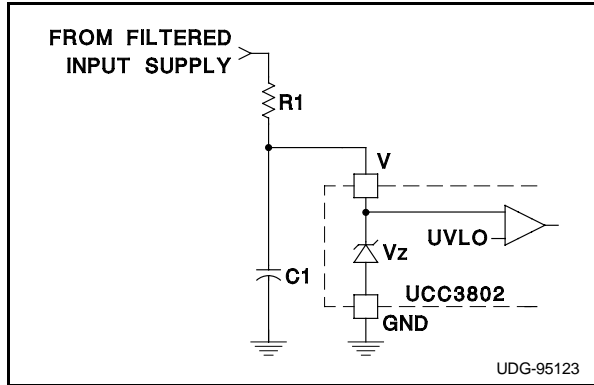

Figure 1. Off-line Current Source Power

UC3802 starts and then uses 1mA for itself, and an additional 2mA (this example) to power the gate drive and other functions.

A drawback to the above circuit is that a good percentage of power is dissipated in R1. If the input voltage range is very wide, or if a high frequency is used or a FET with high gate charge is used, it may not be possible to guarantee that the zener current is limited to 30mA at high line while still being able to provide enough current to run at low line. To create a more efficient input supply, a few alternatives are demonstrated. Figure 2 shows a typical bias supply with modifications for the BiCMOS IC. R1 limits current while the IC is in standby mode so that zener current is not exceeded as in the last example. In this case, the resistor may be made much larger since it will not be the major power source once the sup-

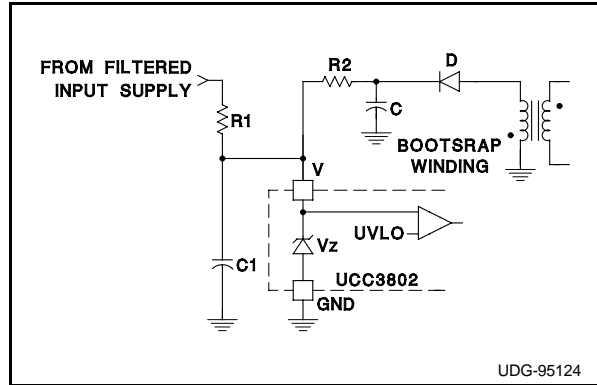

Figure 2. Adding a Bootstrap Supply

ply has started. Resistor R2 is placed in series with the bias supply coming from the transformer in order to again limit the zener current to 10mA. This circuit will result in a higher efficiency than that of the first - at the cost of additional components and a bias winding on the transformer. During start up, C1 again charges through R1 until the turn on threshold of the IC is reached. If R1 is very large, then the UVLO hysteresis of the UCC3802 allows the controller to continue running until it reaches its lower threshold. During this time, the bias supply starts supplying current and should take over as the primary IC power supply before the lower UVLO threshold is reached.

A third solution is to use the Unitrode UCC3889 bias supply control circuitry as seen in Figure 3. This patented control technology will provide a

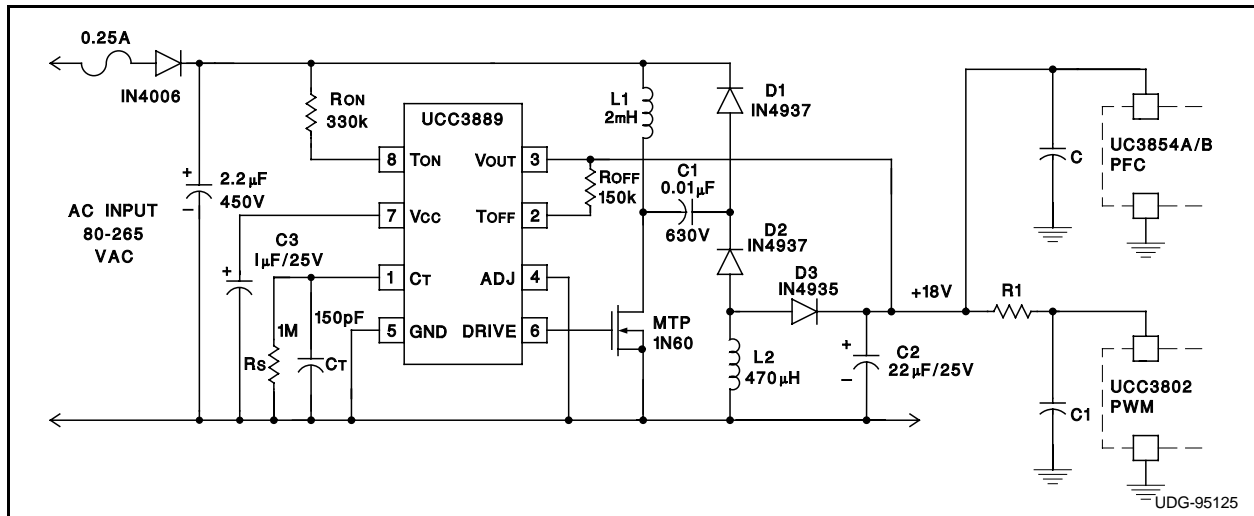

Figure 3. UCC3889 Powers Other Circuits

fully regulated supply from a high input voltage without the use of transformers. As with the last circuit, a series resistor from an 18V input to V_{cc} will limit current. With the UCC3889 IC, an input Power Factor Correction IC or other primary side PWM circuit may also be easily powered.

The UCC3802 and the entire family of Unitrode BiCMOS integrated circuits can provide added efficiency, higher speed, FET totempole output drivers (which eliminate the need for protection Schottky diodes) and other added features. With some care, input power can easily be designed to meet the ICs power requirements, and assist

in designing new, more efficient switching power supplies.

References:

- [1] W. Andreyca, "UCC3800/1/2/3/4/5 BiCMOS Current Mode Control ICs" Unitrode Applications Note U-132.
- [2] J. Palczynski, "UCC3806 BiCMOS Current Mode Control IC" Unitrode Applications Note U-144
- [3] W. Andreyca, "Elegantly Simple Off-Line Bias Supply for Very Low Power Applications" Unitrode Applications Note U-149