

Overcurrent Shutdown with the UC3853

by James Noon

Boost converters are susceptible to large inrush currents at startup and with step changes in V_{LINE} . This is due to the fact that the output capacitor is connected directly to the input through the boost diode. Therefore, controlling the boost MOSFET cannot limit the input current. However, the MOSFET can be protected from the large inrush or overcurrent by forcing the switch off when an overcurrent occurs. This is accomplished with the UC3853 by sensing when an overcurrent has occurred and forcing the FB pin high. Since the UC3853 incorporates a transconductance amplifier for the voltage loop, the FB pin has high input impedance and can easily be pulled up by external circuitry. The UC3853 uses this pin to both regulate the voltage loop and sense when an overvoltage occurs. If the FB pin is forced above 3.15V nominal, the gate drive will be terminated. By tying the overcurrent shutdown circuit into this pin, overcurrent protection can be achieved.

A circuit for providing overcurrent shutdown is shown below (the reference designators correspond with the demo board schematic). The circuit works by having R15 and R14 set the threshold level where the circuit is activated. For example, if $R15 = R14$, at approximately 1.4V across R_{SENSE} Q2 will turn on. Once Q2 turns on, Q3 will be biased on. R17 and R16 set the bias for Q3 (we're assuming negligible drop across Q2 and R14 as a first approximation). Once Q3 turns on the FB pin will be driven high. R18 is sized so that at minimum V_{cc} the voltage divider formed by R18 and the RVD1 gives greater than 3.15V at the FB pin.

The current limit is set by adjusting the voltage divider formed by R14 and R15 such that for the voltage across R_{SENSE} that corresponds to the shutdown current, there is 0.7V across R15.

For more information on the UC3853 please refer to U-159, or contact your Field Application Engineer.

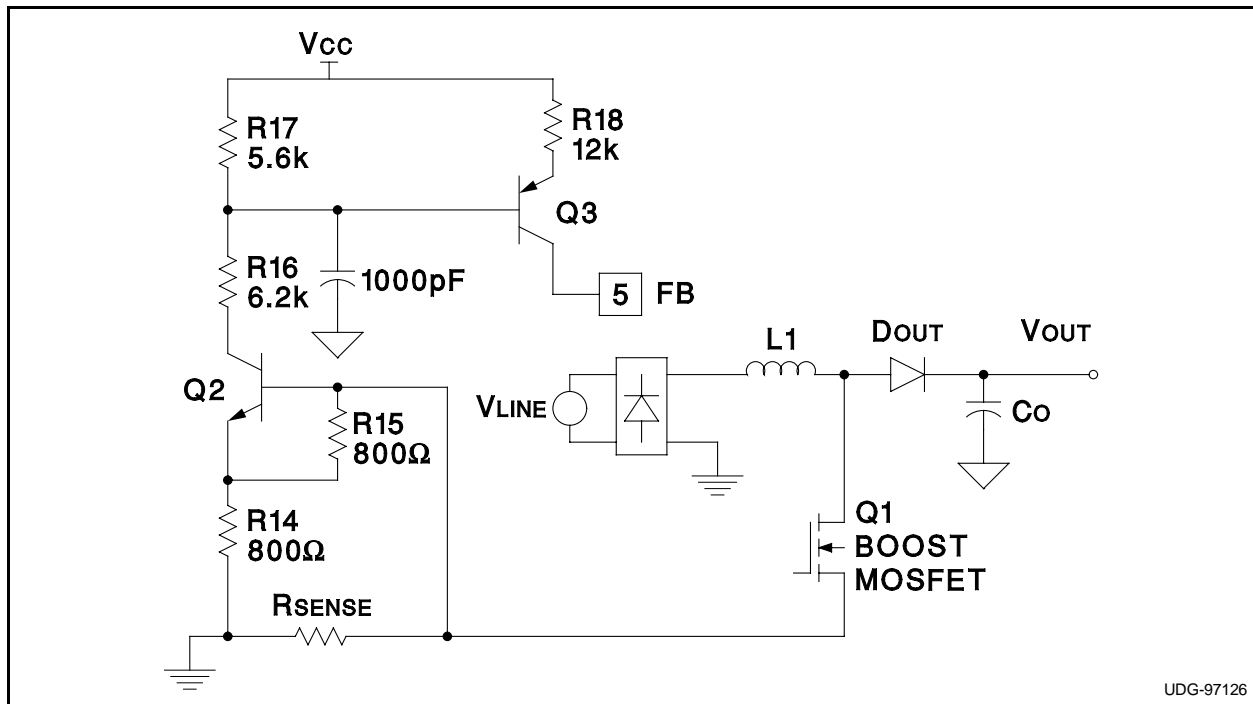

Figure 1.