

Design Note

**UCC3918 “Low On-Resistance Hot Swap Power Manager”,
Evaluation Board, Schematic, and List of Materials**

By Dave Olson

INTRODUCTION

The UCC3918 evaluation kit allows the designer to evaluate the performance of the UCC3918 Low On-Resistance Hot Swap Power Manager in a typical application circuit. The schematic for the evaluation kit is shown in Figure 1.

FEATURES

- Integrated 0.06Ω Power MOSFET
- 3V to 6V Operation
- External Analog Control of Fault Current 0A to 4A
- Independent Analog Control of Current Limit up to 5A
- Overload Protection
- 1μA ICC when Disabled
- Programmable On Time
- Programmable Start Delay
- Fixed 3% Duty Cycle During Fault Conditions

ABSOLUTE MAXIMUM RATINGS

Input Supply Voltage	8V
SOIC Power Dissipation	2.5W
Fault Output Sink Current	50mA
Fault Output Voltage	V_{IN}
Output Current (DC)	Internally Limited
TTL Input Voltage	-0.3V to V_{IN}

Functions of SW1, SW2 and SW3

SW1 and SW2 provide the designer with the flexibility of evaluating the performance of the UCC3918 when residing on either the system backplane or on an adapter card. Closing SW1 after SW2 simulates an application where the UCC3918 resides on a plug-in adapter card. Closing SW1 prior to SW2 simulates an application where the UCC3918 resides on the system backplane. SW3 provides a shutdown input to disable the IC.

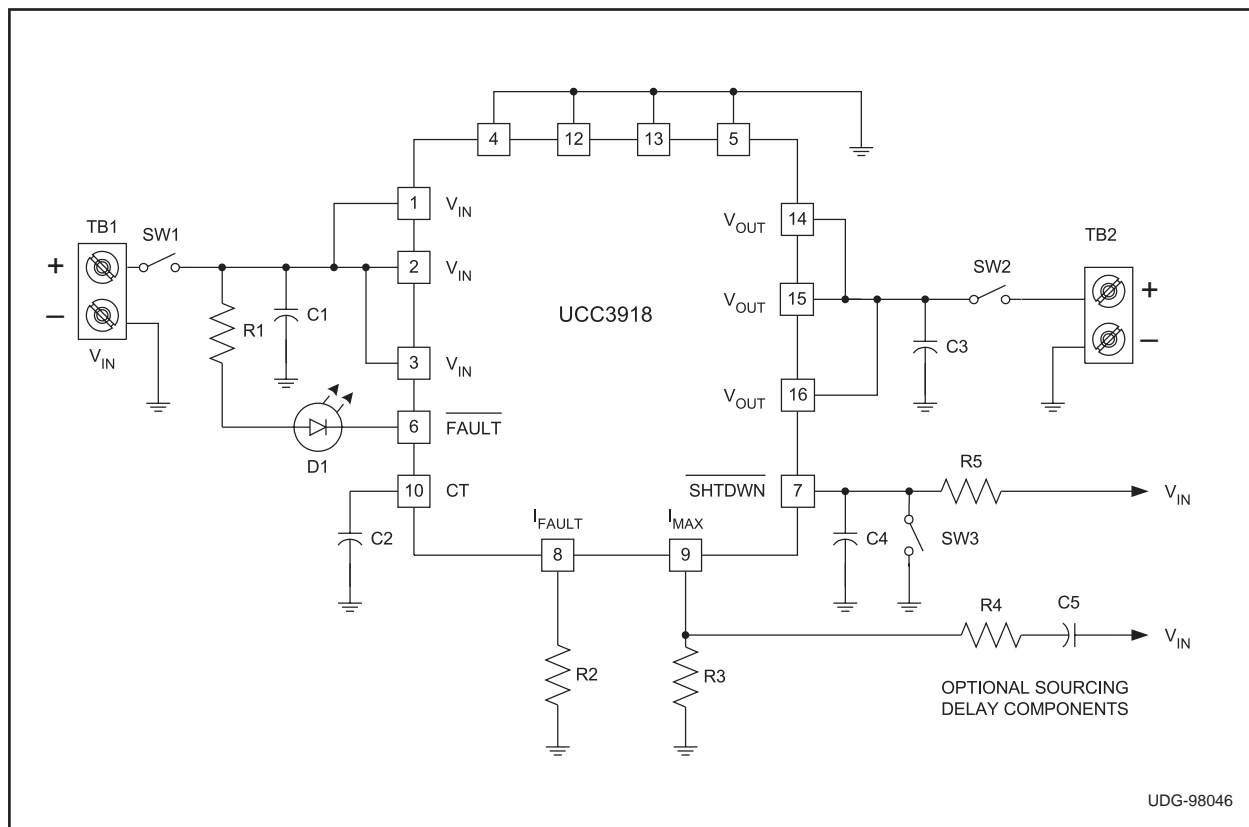

Figure 1. UCC3918 Evaluation Board Schematic

Calculating Maximum Sourcing Current (I_{MAX})

The maximum sourcing current is programmed by selection of R3, connected from pin 9 (I_{MAX}) to GND. R3 can be calculated as:

$$R3 = \frac{105k}{I_{MAX}} \Omega \quad (1)$$

For the UCC3918 evaluation kit R3 is set to 42.2kΩ for I_{MAX} = 3A typical. Please refer to the UCC3918 data sheet for further discussion of I_{MAX}.

Calculating the Fault Current (I_{FAULT})

The I_{FAULT} pin allows linear programming of the fault level current from 0 to 5A. When operating below the fault current the internal FET will be fully enhanced providing low on resistance. When output currents exceed I_{FAULT} the output remains on but the fault timer starts charging CT. R2 sets the current fault level. R2 can be calculated as:

$$R2 = \frac{126k}{I_{FAULT}} \Omega \quad (2)$$

For the UCC3918 evaluation kit R2 is set to 52.3kΩ for I_{FAULT}= 2A typical.

Calculating the Fault and Shutdown Times

The UCC3918 evaluation kit incorporates a 0.1μF timing capacitor, C2 (CT) to set the fault time. The fault and shutdown times can be found by using the following equations.

$$T_{FAULT} = 27.8k \cdot C2 \quad (3)$$

$$T_{SHUTDOWN} = 0.833 \times 10^6 \cdot C2 \quad (4)$$

Where C2 is in Farads and T is in Seconds.

For the evaluation board T_{FAULT} = 2.78mSec and T_{SHUTDOWN}=83.3mSec.

Estimating Maximum Load Capacitance

The maximum load capacitance that can be charged depends on several factors; the nature of the load (constant current or resistive), the maximum sourcing current, and the allowed fault time.

For a constant current load, the maximum capacitance can be estimated from:

$$C_{OUT} = (I_{MAX} - I_{LOAD}) \cdot \left[\frac{27.8 \times 10^3 \cdot C2}{V_{OUT}} \right] \text{Farads} \quad (5)$$

For a resistive load of value RL, C_{OUT} can be estimated from:

$$C_{OUT} = \frac{27.8 \times 10^3 \cdot C2}{RL \cdot \ln \left[\frac{1}{1 - \frac{V_{OUT}}{I_{MAX} \cdot RL}} \right]} \text{Farads} \quad (6)$$

SAFETY RECOMMENDATIONS

Although the UCC3918 is designed to provide system protection for all fault conditions, all integrated circuits can ultimately fail short. For this reason, if the UCC3918 is intended for use in safety critical applications where UL or some other safety agency rating is required, a redundant safety device such as a fuse should be placed in series with the power MOSFET device. The UCC3918 will prevent the fuse from blowing for virtually all fault conditions, increasing system reliability and reducing maintenance cost, in addition to providing the hot swap benefits of the device.

Note: Capacitor C1 is located on the component side of the input switch and will contribute to the inrush current.

For more complete information, pin descriptions and specifications for the UCC3918 Low On-Resistance Hot Swap Power Manager, please refer to the UCC3918 data sheet or contact your Unitrode Field Applications Engineer at (603) 424-2410.

Reference Designator	Description	Manufacturer	Part Number
C1	22 μ F, 25V Tantalum Capacitor	Sprague	199D226X0025DA1
C2	0.1 μ F, 50V Ceramic Capacitor		
C3	22 μ F, 25V Tantalum Capacitor	Sprague	199D226X0025DA1
C4	Not Populated		
C5	Not Populated		
D1	LED		
R1	300 Ω , 0.25W Resistor		
R2	52.3k Ω , 0.25W Resistor		
R3	42.2k Ω , 0.25W Resistor		
R4	Not Populated		
R5	10k Ω , 0.25W Resistor		
SW1	Slide Switch		
SW2	Slide Switch		
SW3	Dip Switch		
TB1	Terminal Block		
TB2	Terminal Block		
U1	Low On-Resistance Hot Swap Power Manager	Unitrode	UCC3918

Table 1. UCC3918 Evaluation Board List of Materials