

UC3717 and L-C Filter Reduce EMI and Chopping Losses in Step Motor

A chopper drive which uses the inductance of the motor as the controlling element causes a temperature rise in the motor due to hysteresis and eddy current losses. For most motors, especially solid rotor constructions, this extra heat can force the designer to go to a larger motor and then derate it, or to a more expensive laminated construction in order to produce enough output torque for the job. Regardless of the motor type, any extra heat generated within a system will have to be removed or else other system components will be stressed unnecessarily. This could mean using a fan where convection cooling might otherwise have sufficed. In addition, the EMI generated from both the motor and its leads is of serious concern to the designer in view of ever-increasing EMI regulations.

These problems can be virtually eliminated by borrowing a simple technique from switching power supply designs, i.e., by placing a properly designed low-pass L-C filter across the output and using *this* L to control the UC3717. This removes the high frequency AC chopping losses in the motor by providing it with almost pure DC current. It also confines the EMI-causing, high frequency AC components to within the driver where they are easier to handle. This could allow increased wire lengths and possibly free up some design constraints, but remember that even though DC emits no EMI, the driver will still commutate the windings and can produce some components of frequency as high as 10 kHz. The design of the L-C filter is straight-forward and its small additional cost can be recovered easily. The Unitrode UC3717, a complete chopper drive for one phase winding on a monolithic IC, makes the design job simple. The end result, a cooler running and EMI quieter step motor, can be achieved with just a few additional passive components.

Preliminary Considerations

For our analysis, we will use a "23" frame, bipolar motor with a solid rotor and the following specifications:

P_{max}	= 9.0 Watts	= Maximum power dissipation at 25°C
V_{max}	= 3.75 Volts	= Maximum voltage per motor phase at 25°C
I_{max}	= 1.25 Amps	= Maximum current per motor phase at 25°C
R_m	= 3.0 Ohms	= Resistance of one phase at 25°C
* L_m	= 8.4 mH	= Inductance of one phase winding

*It should be noted that L_m , as given in a manufacturers data sheet, is not always *true average* inductance as seen at high current in a circuit, but rather the inductance reading you would obtain from a low current inductance bridge. This value can differ from in-circuit inductance by a factor of 2 or more! The in-circuit inductance for this motor is 5.0 mH.

We begin by calculating the electrical time constant of one

phase winding using the resistance value given above and the *actual* motor inductance:

$$\tau_m = \frac{L_m}{R_m} = \frac{5.0 \text{ mH}}{3.0 \text{ Ohms}} = 1.67 \text{ msec} \quad (1)$$

If one were using a standard voltage drive then it would take approximately τ_m or 1.67 msec to reach the current level required for proper operation. This places a severe restriction on motor speed. Increasing the drive voltage will allow the motor to run faster but will cause it to draw too much current and overheat. Maximum motor speed may be increased by decreasing the time constant. Since L_m is fixed, the only parameter we can change is the effective value of R_m by placing a resistor in series with it. If we place a resistor 4 times R_m in series such that total R is 5 times R_m and increase the drive voltage by a factor of 5 then we will have reduced the time constant by a factor of 5 to 330 μ sec and also increased both the maximum motor speed and maximum power output by a factor of 5 each. Unfortunately, we will have increased wasted power by a factor of 5 also.

The Chopper Drive

Using a chopper drive enables one to run at a higher voltage and thus reach proper operating current faster while still protecting the motor from excessive current that would otherwise flow due to the higher voltage. The high voltage is first applied across the motor winding and then, when I_{max} is reached, it is switched off. (If it were not switched off then the maximum current rating of the motor would be quickly exceeded.) The current is then allowed to circulate in a loop within the driver and motor for a fixed time period (t_{off}) after which the voltage is re-applied to the motor. The operating frequency, which is determined by both the motor inductance and t_{off} should be high enough that the resulting current ripple is small compared to the average DC current. Power efficiency is relatively high because there is no external resistor used.

Nothing is free in the world of physics, however, and the price one pays for the extra power output capability is an increase in wasted heat due to hysteresis and eddy current losses *within* the motor instead of in an external resistor. Being within the motor, it can now cause overheating as well as reliability problems. Since the excess heat increases rapidly with the overdrive ratio, this means that at low overdrive ratios (less than 5-to-1) there will be almost negligible heating, but at higher overdrive ratios (more than 10-to-1) the induced motor losses can become as great as, or actually exceed, the I^2R losses! By placing a low-pass L-C filter in the circuit these induced losses can once again become negligible. The L and C components selected should be capable of operating at frequencies of 25 kHz or higher without heating effects in the inductor core or inductive effects in the capacitor.

UC3717 and L-C Filter

Designing with the UC3717

Using a supply voltage (V_s) of 40 volts (approximately a 10/1 overdrive), the turn-on rise-time becomes:

$$t_{rise} = -\tau_m \times \ln(1 - V_m/V_s) = -1.67 \times 10^{-3} \times \ln(1 - 3.75 / 40) = 164 \mu\text{sec} \quad (2)$$

or an improvement of approximately 10-to-1 in speed capability.

Using an off-time (t_{off}) of 30 μsec as suggested on the UC3717 data sheet and limiting current (I_w) to 850 mA establishes a voltage across the resistive component of the winding ($V_{w,on}$) during the "on" time of:

$$V_{w,on} = I_w \times R_w = .85 \times 3.0 = 2.55 \text{ Volts} \quad (3)$$

and during the "off" time (due to a 2.6 volt drop across the upper transistor, as shown in the data sheet, and a 0.4 volt drop across the Schottky "catch" diode) of:

$$V_{w,off} = V_{transistor} + V_{diode} = 2.6 + 0.4 = 3.0 \text{ Volts} \quad (4)$$

Since the voltage and current changes are small, we can substitute a resistance (R_e) equivalent equivalent to $V_{w,off}/I_w$ in series with R_w to adjust the time constant and allow us to calculate the approximate current ripple (ΔI_w) during t_{off} :

$$\Delta I_w = I_w \left(1 - \exp \left[\frac{-t_{off}(R_w + R_e)}{L_m} \right] \right) = .85 \times \left(1 - \exp \left[\frac{-30 \times 10^{-6} \times (3.0 + 3.5)}{5 \times 10^{-3}} \right] \right) = 33 \text{ mA p-p} \quad (5)$$

Knowing ΔI_w , we can now calculate the on-time (t_{on}):

$$t_{on} = \frac{\Delta I_w \times L_m}{V_s - V_{w,on}} = \frac{33 \times 10^{-3} \times 5 \times 10^{-3}}{40 - 2.55} = 4.4 \mu\text{sec} \quad (6)$$

and can also find our operating frequency (f) by:

$$f = 1 / (t_{on} + t_{off}) = 1 / (4.4 + 30) \times 10^{-6} = 29.1 \text{ kHz} \quad (7)$$

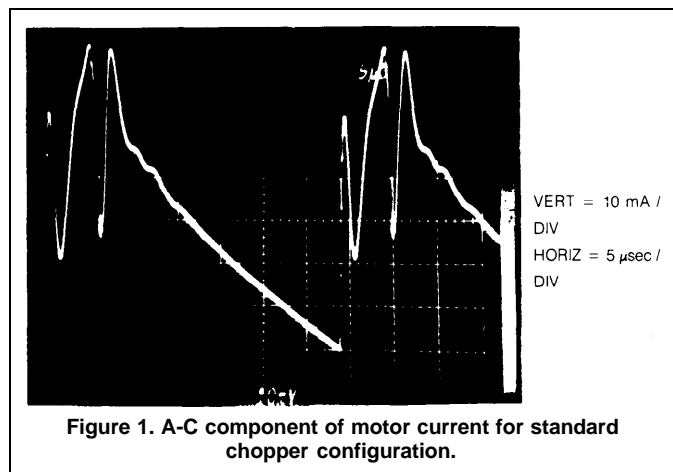

Figure 1. A-C component of motor current for standard chopper configuration.

Since this frequency is well above audible ranges, it will not cause any objectionable sound, but there are still the problems of EMI and excess motor heating to deal with. It is possible to generate EMI due to the current switching that occurs in the motor leads because they carry not only the primary frequency, but also many higher harmonics as well, so they require careful routing, shielding, or both. We can put in a low pass L-C filter to remove these

high frequencies and still pass normal commutation currents without any significant loss of motor performance.

Design of the L-C Filter

Figure 2 is a block diagram of a motor connected to 2 UC3717s with the low-pass L-C filters in place.

Again we will use a current of 850 mA in each winding, an off-time of 30 μsec , and an on-time of 4.4 μsec but now we will use an

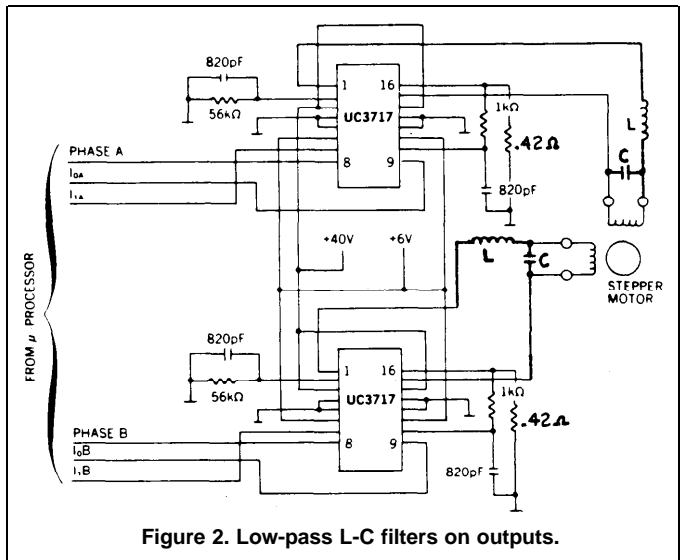

Figure 2. Low-pass L-C filters on outputs.

external inductance (L) to control the chopping. V_{drop} is the sum of the source (V_{so}) and sink (V_{si}) voltage drops at 850 mA:

$$V_{drop} = V_{so} + V_{si} + V_{sense} = (2.6 + 1.9 + 0.36) = 4.9 \text{ volts} \quad (8)$$

In order to minimize the effects of L on the motor current risetime we will make it 10 times smaller than L_m or 500 μH . In order to keep the peak current in the UC3717 below 1 amp we will use a 0.42 ohm sense resistor and also limit ΔI_L to 300 mA. Using a variation of equation (6) we can check that:

$$L = \frac{(V_s - V_{drop}) \times t_{on}}{\Delta I_L} = \frac{(40 - 4.9) \times 4.4 \times 10^{-6}}{300 \times 10^{-3}} = 515 \mu\text{H} \quad (9)$$

is in keeping with the constraints outlined above.

Similarly, we would like to find a value for the capacitor (C) such that it will have less than 1/10 the impedance of L at 29.1 kHz:

$$C = \frac{10}{(2 \times \pi \times f)^2 \times L} = \frac{10}{(2 \times 3.14 \times 29100)^2 \times 500 \times 10^{-6}} = 0.6 \mu\text{F} \quad (10)$$

The test motor and driver, operated unloaded (nothing connected to the output shaft) and in the configuration of Figure 2, used values of 500 μH for the inductor and 0.47 μF for the capacitor. Figure 1 and Figures 3 through 6 are waveforms obtained from that motor.

The lower trace of Figure 3 (Figure 3b) shows the 330 mA current sawtooth in the inductor, while the upper trace (Figure 3a) shows an 8 mA p-p current ripple in the motor winding. While this may seem to indicate only a 12 dB reduction in EMI over Figure 1, comparing the sinusoidal waveform of Figure 3a to the "noisy" sawtooth waveform of Figure 1 will quickly point out sources of

UC3717 and L-C Filter

EMI. In *Figure 1*, the oscillations immediately following each switch of the driver are due to the motor's distributed capacitance resonating with its inductance and are a possible source of EMI. In addition, sharp current spikes are allowed to pass along the motor leads and through the motor's distributed capacitance unhindered, thus creating high frequency EMI. EMI spikes were virtually eliminated from *Figure 3a* by using a low ESR capacitor and connecting the motor leads close to the body of the capacitor.

Figure 4 shows motor current superimposed over the inductor current. Just to the left of the center graticle line a ringing occurs in the inductor current that also appears in the motor current, although attenuated. This ringing occurs at a frequency of:

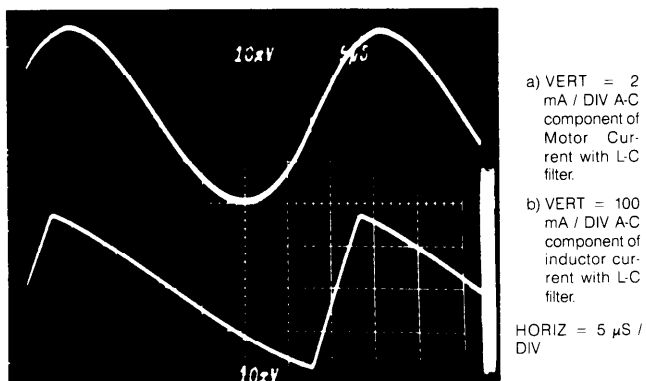

Figure 3. Motor and inductor current waveforms.

$$f_{res} = 1 / 2 \pi \sqrt{L \times C} = 1 / 6.28 \times \sqrt{500 \times 10^{-6} \times 0.47 \times 10^{-6}} = 10.4 \text{ kHz} \quad (11)$$

which is the resonant frequency of the L-C filter. This frequency can be lowered by increasing the value of either L or C, although at a cost of reducing the high speed performance of the motor.

The high frequency sawtooth waveforms at the upper, flat portion of the motor current waveform are the 29.1 kHz chopping currents in the inductor. They cause a small corresponding ripple in the motor current but, because the chopping frequency is more than twice the break frequency of the 2-pole L-C filter, we would expect, and can see, an attenuation greater than 12 dB.

In a 2 phase step motor (sometimes referred to as a 4 phase step motor because of the 4 windings used in the unipolar version) the STEP RATE, in full steps per second (FSPS), is 4 times the primary frequency of the motor current waveform. The two phases of

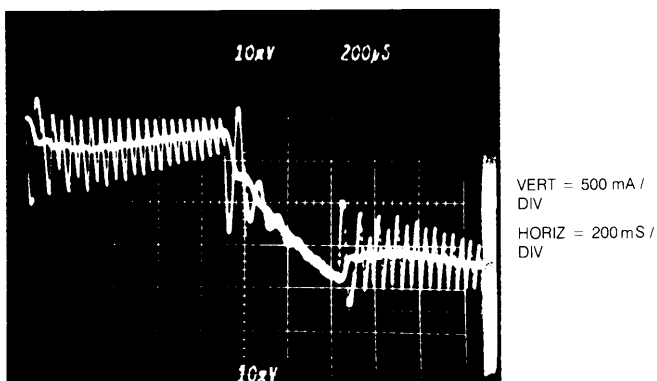

Figure 4. Filter current waveform superimposed over motor current waveform.

the step motor are operated in quadrature and thus will generate 4 distinct states in the 2 phases which correspond to 4 mechanical steps for each electrical cycle.

$$\text{FSPS} = 4 \times \text{frequency (for a 2 or "4" phase step motor)} \quad (12)$$

It is important to note at this time that 10.4 kHz is the highest frequency that can be passed to this motor without attenuation using the selected components, but that this corresponds to a step rate of 41,600 FSPS! The test motor was able to run at 17,000 full steps per second with the L-C filter in place, which is high enough for most situations.

Figures 5 and 6 are current waveforms for the motor running at 1600 FSPS and 16,000 FSPS respectively. The motor was operated with the L-C filter on only the lower trace winding so that the waveforms could be compared easily. Looking at *Figure 5*, one can see that the leading edges of both waveforms have the same

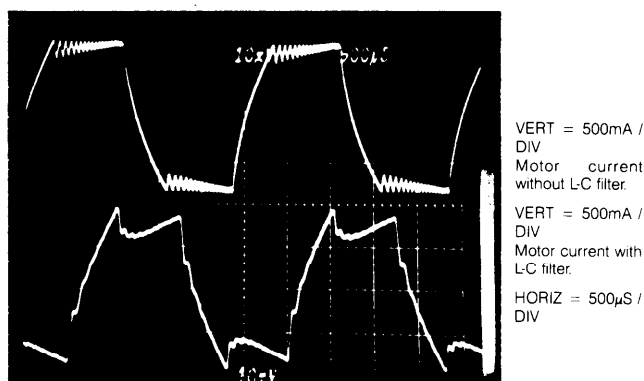

Figure 5. Motor currents at 1600 FSPS.

risetimes, although the filtered one has more susceptibility toward ringing. From *Figure 6*, one can see that torque is down only 3 dB at 16,000 FSPS and that there are "glitches" in the unfiltered waveform that do not appear in the filtered waveforms.

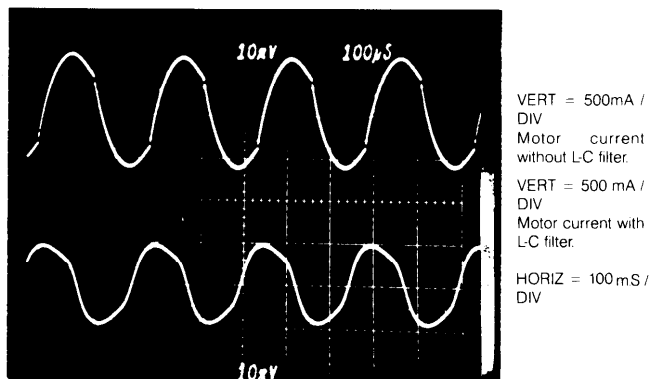

Figure 6. Motor currents at 16,000 FSPS.

Conclusions

The use of a low-pass filter can be an effective heat and EMI reduction mechanism when used with a step motor chopper driver such as the UC3717. The price one pays for a "clean" EMI environment is a *small* loss in very high speed performance. The technique may be applied equally well to non-IC chopper drivers but the peak currents must be accounted for and the minimum value of L adjusted accordingly. 500 μH is the smallest practical L that should be used with the UC3717 since we do not want the

UC3717 and L-C Filter

peak of the ripple to exceed 1.0 amps. This limits the usefulness of the technique to motors with inductances of 2 mH or more. At average currents less than 300 mA, the value of L may have to be

larger in order to maintain continuous current in the inductor, but the physical size may be decreased. If an average current in excess of 850 mA is required, then a power amplifier may be added as shown in *Figure 7*. This will extend the peak current capabilities of the chopper drive to higher current and will also allow the value of L to be decreased.

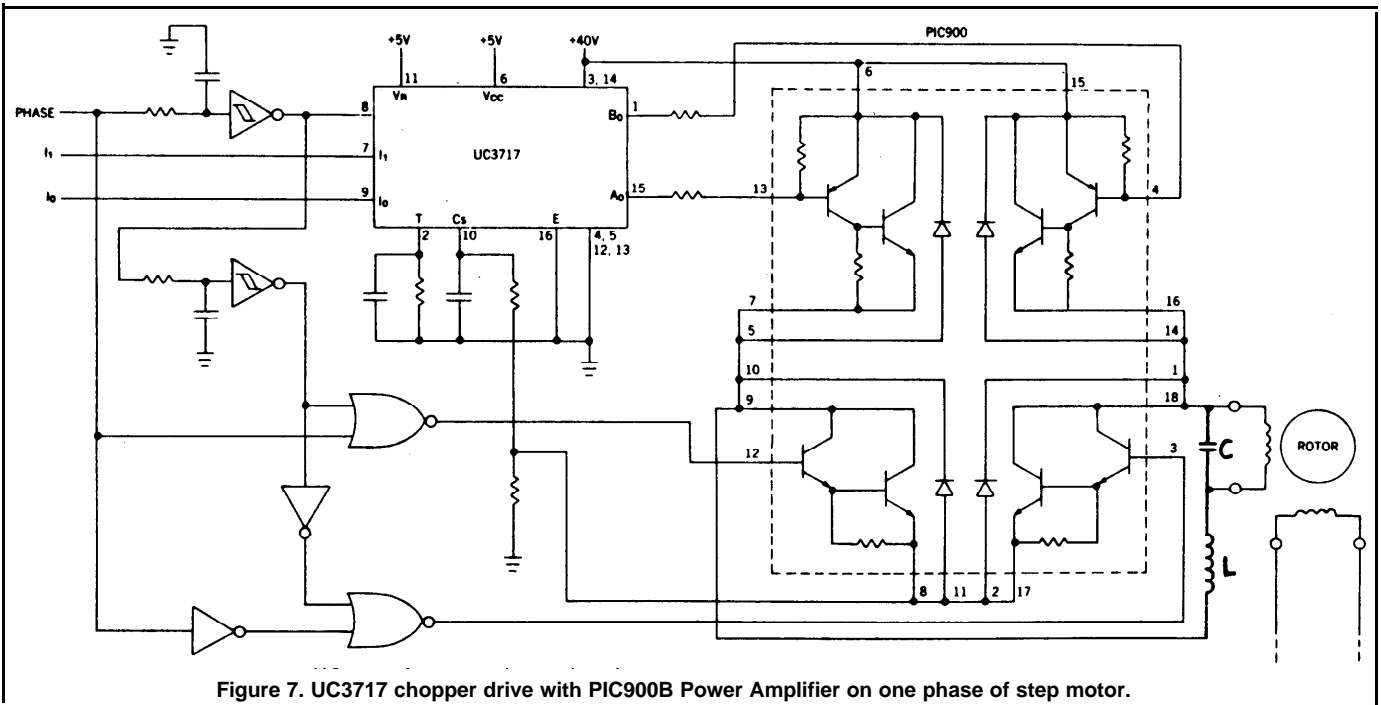

Figure 7. UC3717 chopper drive with PIC900B Power Amplifier on one phase of step motor.