

Negative Voltage Hot Swap Power Manager

FEATURES:

- Precision Fault Threshold
- Programmable Average Power Limiting
- Programmable Linear Current Control
- Programmable Overcurrent Limit
- Programmable Fault Time
- Fault Output Indication
- Shutdown Control
- Undervoltage Lockout
- 8-Pin SOIC

DESCRIPTION:

The UCC1913 family of negative voltage circuit breakers provides complete power management, hot swap, and fault handling capability. The IC is referenced to the negative input voltage and is driven through an external resistor connected to ground, which is essentially a current drive as opposed to the traditional voltage drive. The on-board 10V shunt regulator protects the IC from excess voltage and serves as a reference for programming the maximum allowable output sourcing current during a fault. All control and housekeeping functions are integrated, and externally programmable. These include the fault current level, maximum output sourcing current, maximum fault time, soft start time, and average power limiting. In the event of a constant fault, the internal timer will limit the on-time from less than 0.1% to a maximum of 3%. The duty cycle modulates depending on the current into the PL pin, which is a function of the voltage across the FET, and will limit average power dissipation in the FET. The fault level is fixed at 50mV across the current sense amplifier to minimize total dropout. The fault current level is set with an external current sense resistor. The maximum allowable sourcing current is programmed with a voltage divider from VDD to generate a fixed voltage on the IMAX pin. The current level, when the output appears as a current source, is equal to V_{IMAX}/R_{SENSE} . If desired, a controlled current startup can be programmed with a capacitor on the IMAX pin.

When the output current is below the fault level, the output device is switched on. When the output current exceeds the fault level, but is less than the maximum sourcing level programmed by the IMAX pin, the output remains switched on, and the fault timer starts charging CT. Once CT charges to 2.5V, the output device is turned off and performs a retry some time later. When the output current reaches the maximum sourcing current level, the output appears as a current source, limiting the output current to the set value defined by IMAX.

Other features of the UCC1913 family include undervoltage lockout, and 8-pin Small Outline (SOIC) and Dual-In-Line (DIL) packages.

BLOCK DIAGRAM

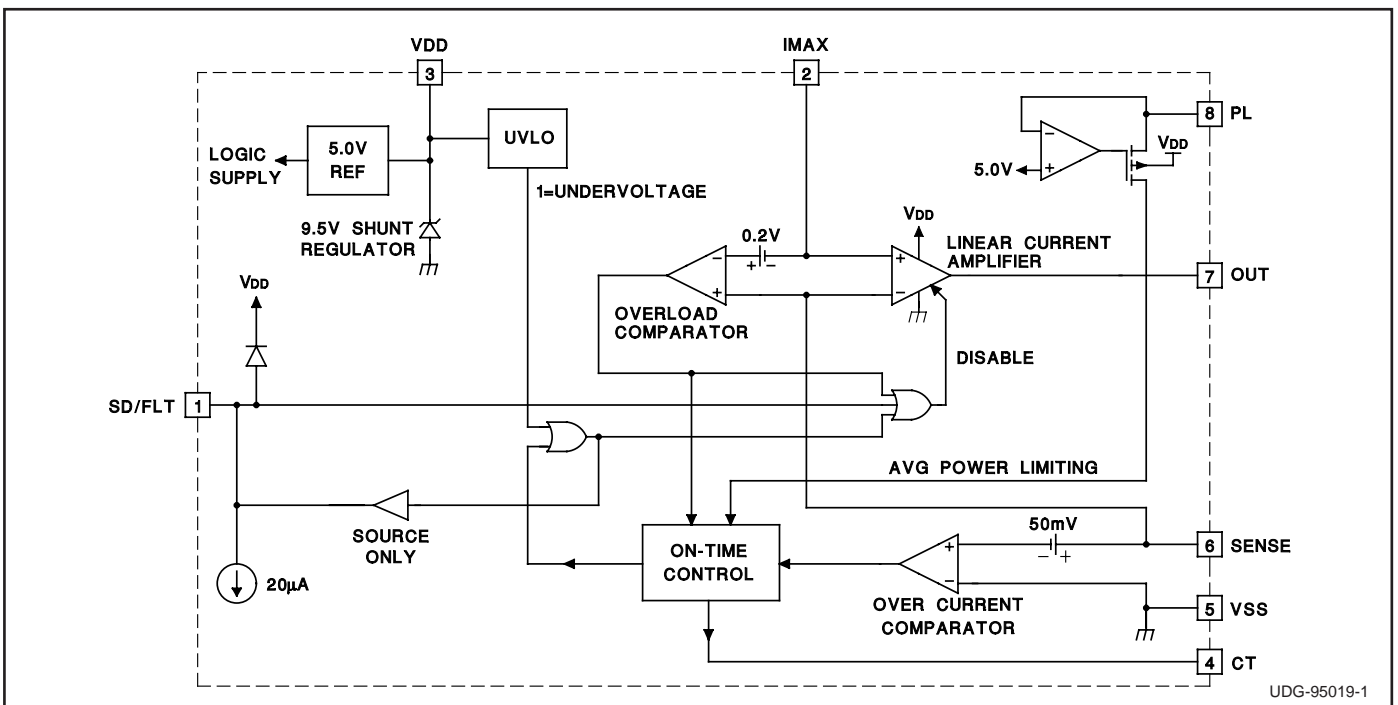

ABSOLUTE MAXIMUM RATINGS

I _{VCC}50mA
SHUTDOWN Current	10mA
PL Current	10mA
I _{MAX} Input Voltage	V _{CC}
Storage Temperature	-65°C to +150°C
Junction Temperature	-55°C to +150°C
Lead Temperature (Soldering, 10 sec.)	+300°C

All voltages are with respect to VSS (The most Negative voltage). All currents are positive into, negative out of the specified terminal. Consult Packaging Section of Databook for thermal limitations and considerations of packages.

CONNECTION DIAGRAM

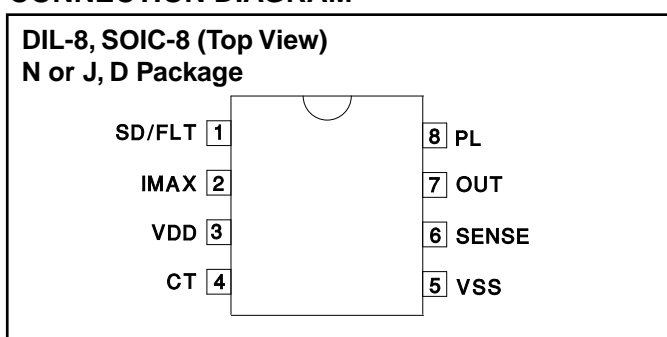

ELECTRICAL CHARACTERISTICS Unless otherwise stated these specifications apply for T_A = -55°C to +125°C for UCC1913; -40°C to +85°C for UCC2913; 0°C to +70°C for UCC3913; I_{VDD} = 2mA, C_T = 4.7pF, T_A = T_J.

PARAMETER	TEST CONDITIONS	MIN	TYP	MAX	UNITS
VDD Section					
IDD			1.0	2.0	mA
Regulator Voltage	I _{SOURCE} = 2mA to 10mA	8.5	9.5	10.5	V
UVLO Off Voltage		6	7	8	V
Fault Timing Section					
Overcurrent Threshold	T _J = 25°C	47.5	50	53	mV
Overcurrent Threshold	Over Operating Temperature	46	50	53.5	mV
Overcurrent Input Bias			50	500	nA
CT Charge Current	V _{CT} = 1.0V, I _{PL} = 0	-50	-36	-22	μA
	Overload Condition, V _{SENSE} - V _{IMAX} = 300mV	-1.7	-1.2	-0.7	mA
CT Discharge Current	V _{CT} = 1.0V, I _{PL} = 0	0.6	1	1.5	μA
CT Fault Threshold		2.2	2.4	2.6	V
CT Reset Threshold		0.32	0.5	0.62	V
Output Duty Cycle	Fault Condition, I _{PL} = 0	1.7	2.7	3.7	%
Output Section					
Output High Voltage	I _{OUT} = 0A	8.5	10		V
	I _{OUT} = -1mA	6	8		V
Output Low Voltage	I _{OUT} = 0A; V _{SENSE} - V _{IMAX} = 100MV		0	0.01	V
	I _{OUT} = 2mA; V _{SENSE} - V _{IMAX} = 100MV		0.2	0.6	V
Linear Amplifier Section					
Sense Control Voltage	I _{MAX} = 100mV	85	100	115	mV
	I _{MAX} = 400mV	370	400	430	mV
Input Bias			50	500	nA
Shutdown/Fault Section					
Shutdown Threshold		1.4	1.7	2.0	V
Input Current	Shutdown = 5V	15	25	45	μA
Fault Output High		6	7.5	9	V
Fault Output Low			0	0.01	V
Delay to Output	Note 1		150	300	ns
Power Limiting Section					
V _{SENSE} Reg. Voltage	I _{PL} = 64μA	4.35	4.85	5.35	V
Duty Cycle Control	I _{PL} = 64μA	0.6	1.2	1.7	%
	I _{PL} = 1mA	0.045	0.1	0.17	%
Overload Section					
Delay to Output	Note 1		300	500	ns
Output Sink Current	V _{SENSE} - V _{IMAX} = 300mV	40	100		mA
Threshold	Relative to I _{MAX}	140	200	260	mV

Note 1 : Guaranteed by design. Not 100% tested in production.

PIN DESCRIPTIONS

CT: A capacitor is connected to this pin in order to set the maximum fault time. The maximum fault time must be more than the time to charge external load capacitance. The maximum fault time is defined as $T_{FAULT} = (2 \cdot CT) / I_{CH}$, where $I_{CH} = 36\mu A + I_{PL}$, and I_{PL} is the current into the power limit pin. Once the fault time is reached the output will shutdown for a time given by: $T_{SD} = 2 \cdot 10^6 \cdot CT$.

IMAX: This pin programs the maximum allowable sourcing current. Since VDD is a regulated voltage, a voltage divider can be derived from VDD to generate the program level for the IMAX pin. The current level at which the output appears as a current source is equal to the voltage on the IMAX pin over the current sense resistor. If desired, a controlled current startup can be programmed with a capacitor on the IMAX pin, and a programmed start delay can be achieved by driving the shutdown with an open collector/drain device into an RC network.

OUT: Output drive to the MOSFET pass element.

PL: This feature ensures that the average MOSFET power dissipation is controlled. A resistor is connected from this pin to the drain of the NMOS pass element. When the voltage across the NMOS exceeds 5V, current will flow into the PL pin which adds to the fault timer

charge current, reducing the duty cycle from the 3% level. When $I_{PL} \gg 36\mu A$ then the average MOSFET power dissipation is given by:

$$P_{FET\ AVG} = I_{MAX} \cdot 1 \cdot 10^{-6} \cdot R_{PL}$$

SENSE: Input voltage from the current sense resistor. When there is greater than 50mV across this pin with respect to VSS, then a fault is sensed, and CT starts to charge.

SD/FLT: This pin provides fault output indication and shutdown control. Interphase into and out of this pin is usually performed through level shift transistors. When $20\mu A$ is sourced into this pin, shutdown drives high causing the output to disable the NMOS pass device. When opened, and under a non-fault condition, the SD/FLT pin will pull to a low state. When a fault is detected by the fault timer, or undervoltage lockout, this pin will drive to a high state, indicating the output FET is OFF.

VDD: Current driven with a resistor to a voltage at least 10V more positive than VSS. Typically a resistor is connected to ground. The 10V shunt regulator clamps VDD at 10V above the VSS pin, and is also used as an output reference to program the maximum allowable sourcing current.

VSS: Ground reference for the IC and the most negative voltage available.

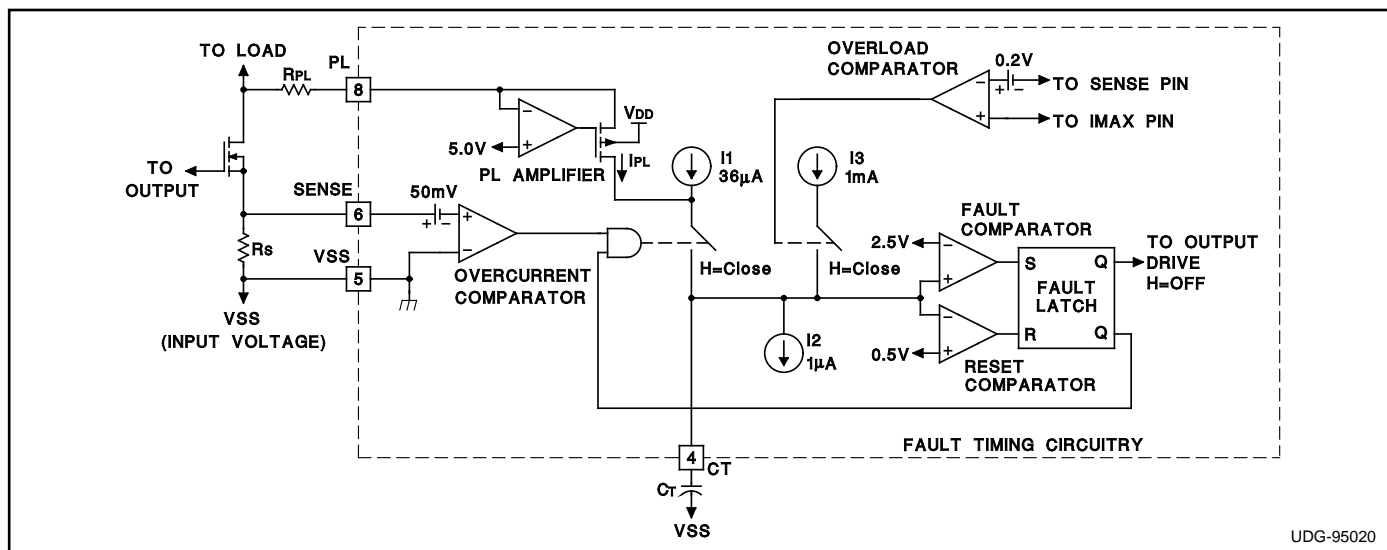
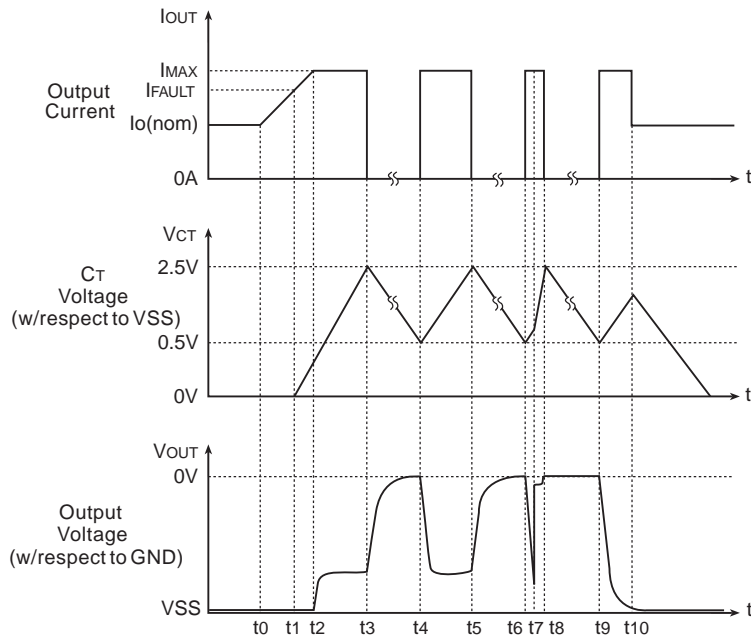

Figure 1. Fault timing circuitry for the UCC1913, including power limit overload.

Figure 1 shows the detailed circuitry for the fault timing function of the UCC1913. For the time being, we will discuss a typical fault mode, therefore, the overload comparator, and current source I₃ does not work into the operation. Once the voltage across the current sense resistor, R_s, exceeds 50mV, a fault has occurred. This causes the timing capacitor to charge with a combination

of 36µA plus the current from the power limiting amplifier. The PL amplifier is designed to only source current into the CT pin and to begin sourcing current once the voltage across the output FET exceeds 5V. The current I_{PL} is related to the voltage across the FET with the following expression:



- t0: safe condition – output current is nominal, output voltage is at the negative rail, VSS.
- t1: fault control reached – output current rises above the programmed fault value, CT begins to charge at $\approx 36\mu\text{A}$.
- t2: max current reached – output current reaches the programmed maximum level and becomes a constant current with value I_{MAX}.
- t3: fault occurs – CT has charged to 2.5V, fault output goes high, the FET turns off allowing no output current to flow, V_{OUT} floats up to ground.
- t4: retry – CT has discharged to 0.5V, but fault current is still exceeded, CT begins charging again, FET is on, V_{OUT} pulled down to VSS.
- t5 = t3: illustrates 3% duty cycle.
- t6 = t4
- t7: output short circuit - if V_{OUT} is short circuited to ground, CT charges at a higher rate depending upon the values for VSS and R_{PL}.
- t8: fault occurs – output is still short circuited, but the occurrence of a fault turns the FET off so no current is conducted.
- t9 = t4: output short circuit released, still in fault mode.
- t10 = t0: fault released, safe condition – return to normal operation of the circuit breaker.

Figure 2. Typical Timing Diagram

$$I_{PL} = \frac{V_{FET} - 5V}{R_{PL}}$$

Where V_{FET} is the voltage across the NMOS pass device.

Later it will be shown how this feature will limit average power dissipation in the pass device. Note that under a condition where the output current is more than the fault level, but less than the max level, V_{OUT} ~ VSS (input voltage), I_{PL} = 0, the CT charging current is 36μA.

During a fault, CT will charge at a rate determined by the

internal charging current and the external timing capacitor. Once CT charges to 2.5V, the fault comparator switches and sets the fault latch. Setting of the fault latch causes both the output to switch off and the charging switch to open. CT must now discharge with the 1μA current source, I₂, until 0.5V is reached. Once the voltage at CT reaches 0.5V, the fault latch resets, which re-enables the output and allows the fault circuitry to regain control of the charging switch. If a fault is still present, the fault comparator will close the charging switch causing the cycle to begin. Under a constant fault, the duty cycle is given by:

$$\text{Duty cycle} = \frac{1\mu\text{A}}{I_{PL} + 36\mu\text{A}}$$

Average power dissipation in the pass element is given by:

$$P_{FET\ AVG} = V_{FET} \cdot I_{MAX} \cdot \frac{1\mu\text{A}}{I_{PL} + 36\mu\text{A}}$$

Where $V_{FET} \gg 5V$ I_{PL} can be approximated as: $\frac{V_{FET}}{R_{PL}}$

and where $I_{PL} \gg 36\mu\text{A}$, the duty cycle can be approximated as: $\frac{1\mu\text{A} \cdot R_{PL}}{V_{FET}}$

Therefore, the maximum average power dissipation in the MOSFET can be approximated by:

$$P_{FET\ AVG} = V_{FET} \cdot I_{MAX} \cdot \frac{1\mu\text{A} \cdot R_{PL}}{V_{FET}} = I_{MAX} \cdot 1\mu\text{A} \cdot R_{PL}$$

Notice that in the approximation, V_{FET} cancels. Therefore, average power dissipation is limited in the NMOS pass element.

Overload Comparator

The linear amplifier in the UCC1913 ensures that the output NMOS does not pass more than I_{MAX} (which is V_{IMAX}/R_s). In the event the output current exceeds the programmed I_{MAX} by $0.2V/R_s$, which can only occur if the output FET is not responding to a command from the IC, the CT pin will begin charging with I_3 , 1mA, and continue to charge to approximately 8V. This allows a constant fault to show up on the SD/FLT pin, and also since the voltage on CT will only charge past 2.5V in an overload fault mode, it can be used for detection of output FET failure or to build in redundancy in the system.

Determining External Component Values

Referring now to Figure 3. To set R_{VDD} the following must be achieved

$$\frac{V_{INmin}}{R_{VDD}} > \frac{10V}{R_1 + R_2} + 2mA$$

In order to estimate the minimum timing capacitor, C_T , several things must be taken into account. For example, given the schematic below as a possible (and at this

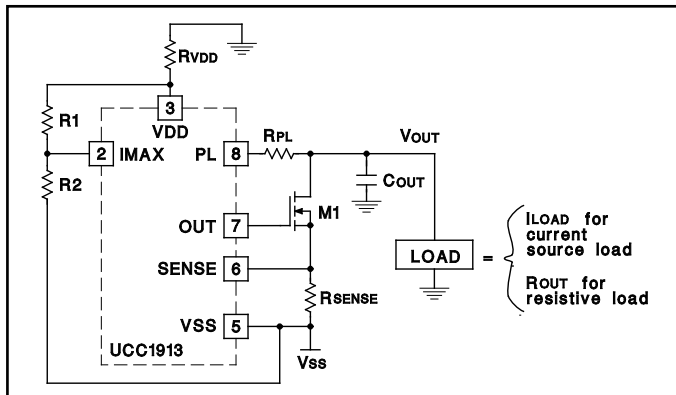

Figure 3.

point, a standard) application, certain external component values must be known in order to estimate C_{Tmin} .

Now, given the values of C_{OUT} , R_{SENSE} , V_{SS} , and the resistors determining the voltage on the I_{MAX} pin, the user can calculate the approximate startup time of the node V_{OUT} . This startup time must be faster than the time it takes for C_T to charge to 2.5V (relative to V_{SS}), and is the basis for estimating the minimum value of C_T . In order to determine the value of the sense resistor, R_{SENSE} , assuming the user has determined the fault current, R_{SENSE} can be calculated by:

$$R_{SENSE} = \frac{50mV}{I_{FAULT}}$$

Next, the variable I_{MAX} must be calculated. I_{MAX} is the maximum current that the UCC1913 will allow through the transistor, M1, and it can be shown that during startup with an output capacitor the power MOSFET, M1, can be modeled as a constant current source of value I_{MAX} where

$$I_{MAX} = \frac{V_{IMAX}}{R_{SENSE}} \text{ where } V_{IMAX} = \text{voltage on pin } I_{MAX}.$$

Given this information, calculation of the startup time is now possible via the following:

Current Source Load:

$$T_{START} = \frac{C_{OUT} \cdot |V_{SS}|}{I_{MAX} - I_{LOAD}}$$

Resistive Load:

$$T_{START} = C_{OUT} \cdot R_{OUT} \cdot \ln\left(\frac{I_{MAX} \cdot R_{OUT}}{I_{MAX} \cdot R_{OUT} - |V_{SS}|}\right)$$

Once T_{START} is calculated, the power limit feature of the UCC1913 must be addressed and component values derived. Assuming the user chooses to limit the maximum allowable average power that will be associated with the circuit breaker, the power limiting resistor, R_{PL} , can be easily determined by the following:

$$R_{PL} = \frac{P_{FET\ AVG}}{1\mu\text{A} \cdot I_{MAX}} \text{ where a minimum } R_{PL} \text{ exists}$$

defined by $R_{PLmin} = \frac{|V_{SS}|}{5mA}$

Finally, after computing the aforementioned variables, the minimum timing capacitor can be derived as such:

Current Source Load:

$$C_{Tmin} = \frac{3 \cdot T_{START} \cdot (62\mu\text{A} \cdot R_{PL} + |V_{SS}| - 10V)}{10 \cdot R_{PL}}$$

Resistive Load:

$$C_{Tmin} = \frac{3 \cdot T_{START} \cdot (31\mu\text{A} \cdot R_{PL} + |V_{SS}| - 5V - I_{MAX} \cdot R_{OUT})}{5 \cdot R_{PL}} + \frac{3 \cdot R_{OUT} \cdot |V_{SS}| \cdot C_{OUT}}{5 \cdot R_{PL}}$$

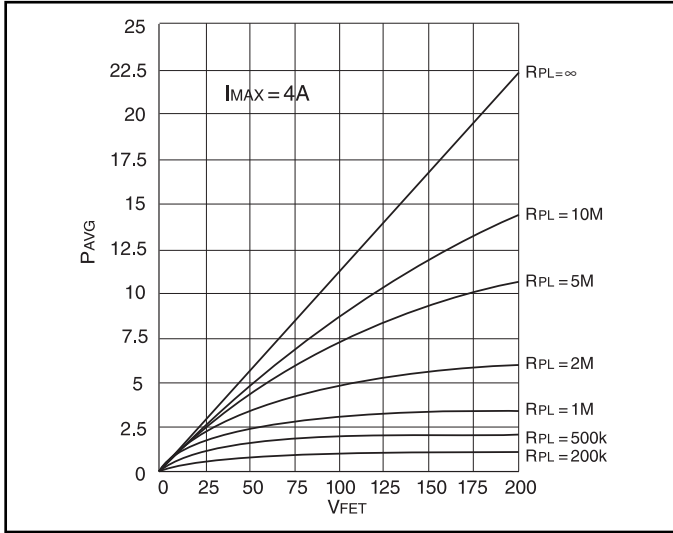

Figure 4. Plot Average Power vs. FET Voltage for Increasing Values of RPL.

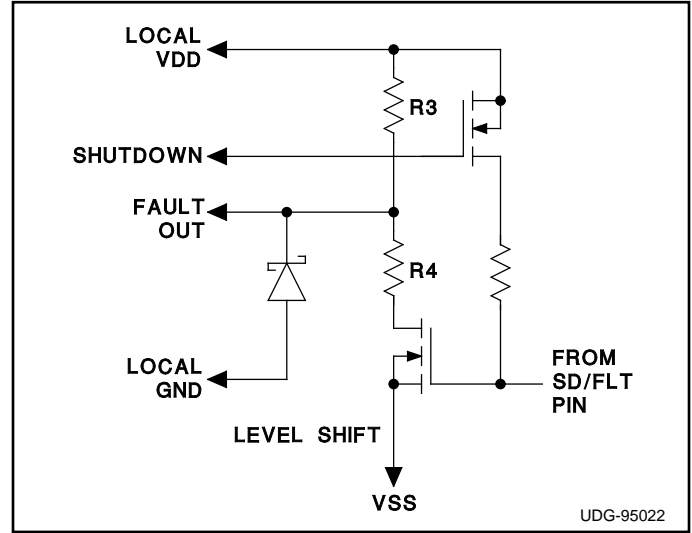
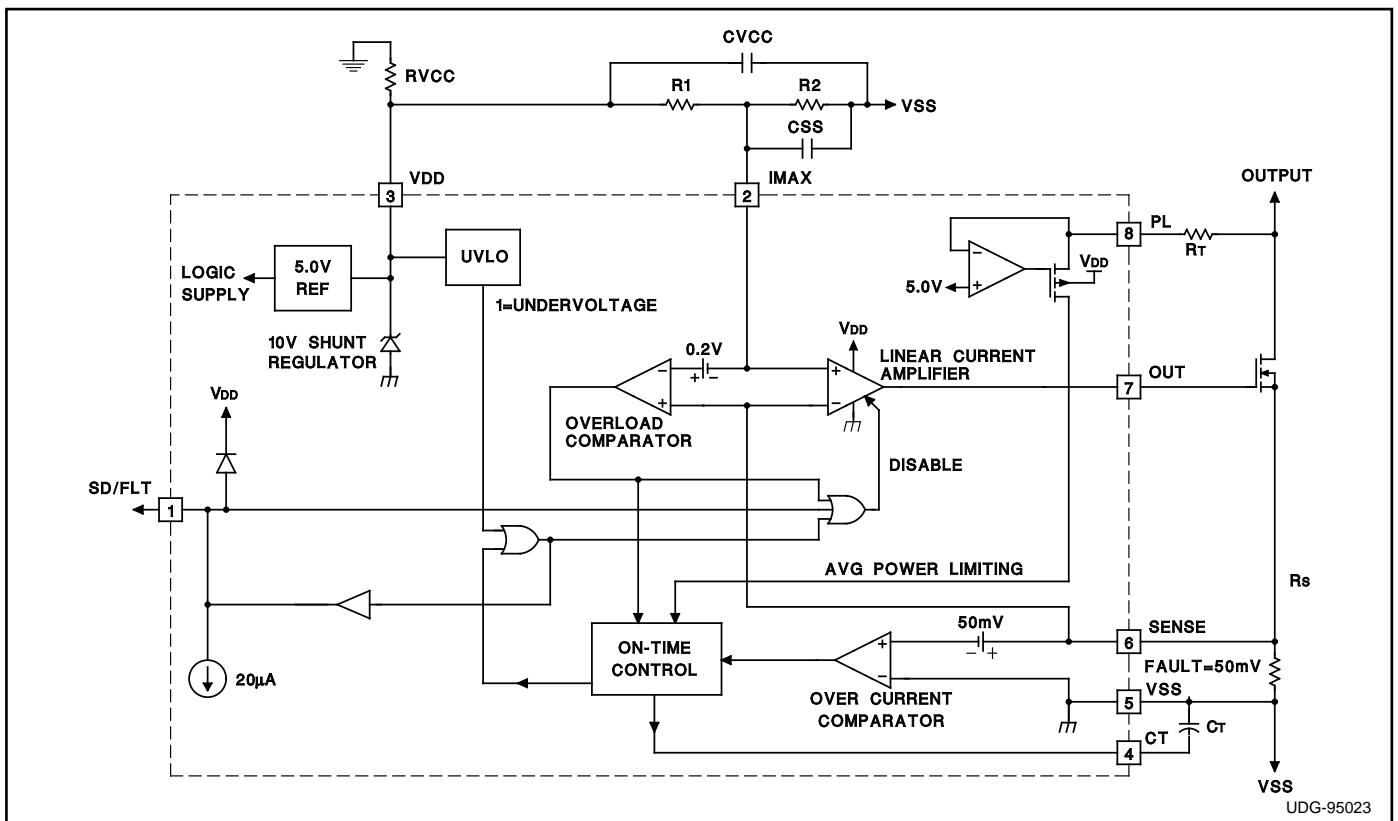

Figure 5. Possible Level Shift Circuitry to Interface to the UCC1913.

APPLICATION DIAGRAM



SAFETY RECOMMENDATIONS

Although the UCC3913 is designed to provide system protection for all fault conditions, all integrated circuits can ultimately fail short. For this reason, if the UCC3913 is intended for use in safety critical applications where UL or some other safety rating is required, a redundant

safety device such as a fuse should be placed in series with the device. The UCC3913 will prevent the fuse from blowing for virtually all fault conditions, increasing system reliability and reducing maintenance cost, in addition to providing the hot swap benefits of the device.