

# Phase Locked Frequency Controller

## FEATURES

- Precision Phase Locked Frequency Control System
- Communication Logic for 2-Phase Motors
- Disable Input for Motor Inhibit
- Crystal Oscillator
- Programmable Reference Frequency Dividers
- Phase Detector with Absolute Frequency Steering
- Digital Lock Indicator
- Two High Current Op-Amps
- 5V Reference Output

## DESCRIPTION

The UC1634 series of devices is optimized to provide precision phase locked frequency control for two phase DC brushless motors. These devices include most of the features of the general purpose UC1633 Phase Locked Control family and also provide the out-of-phase commutation signals required for driving two phase brushless motors. Only an external power booster stage is required for a complete drive and control system.

The two commutation outputs are open collector devices that can sink in excess of 16mA. A disable input allows the user to simultaneously force both of these outputs to an active low state. Double edge logic, following the sense amplifier, doubles the reference frequency at the phase detector by responding to both edges of the input signal at Pin 7.

## BLOCK DIAGRAM

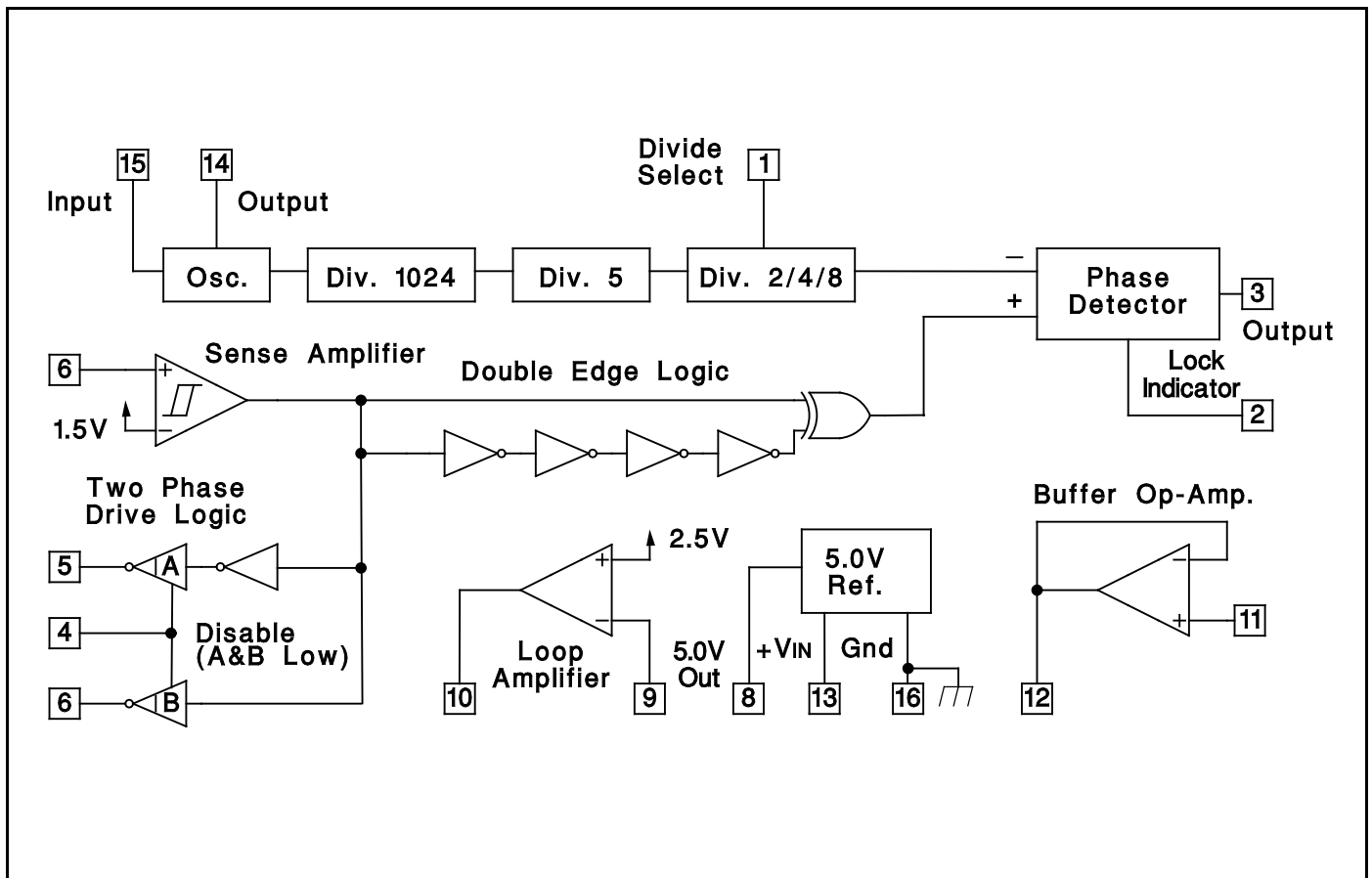

**ABSOLUTE MAXIMUM RATINGS** (Note 1, 2)

Input Supply Voltage (+VIN) . . . . .	+20V
Reference Output Current . . . . .	-30mA
Op-Amp Output Currents . . . . .	±30mA
Op-Amp Input Voltages . . . . .	-3V to +20V
Phase Detector Output Current . . . . .	±10mA
Lock Indicator Output Current . . . . .	+15mA
Lock Indicator Output Voltage . . . . .	+20V
Divide Select Input Voltage . . . . .	-3V to +10V
Disable Input Voltage . . . . .	-3V to +10V
Oscillator Input Voltage . . . . .	-3V to +5V
Sense Amplifier Input Voltage . . . . .	-3V to +20V
Driver Output Currents . . . . .	+30mA
Driver Output Voltages . . . . .	+20V
Power Dissipation at TA = 25°C (Note 2) . . . . .	1000mW
Power Dissipation at TC = 25°C (Note 2) . . . . .	2000mW
Operating Junction Temperature . . . . .	-55°C to +150°C
Storage Temperature . . . . .	-65°C to +150°C
Lead Temperature (Soldering, 10 Seconds) . . . . .	300°C

Note 1: Voltages are referenced to ground, (Pin 16, DIL Package). Currents are positive into, negative out of, the specified terminals.

Note 2: Consult Packaging Section of Databook for thermal limitations and considerations of package.

**CONNECTION DIAGRAMS**

**PLCC-20 (TOP VIEW)  
Q Package**

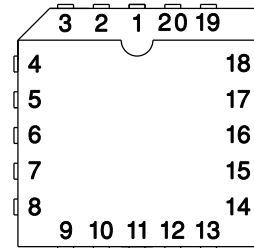

PACKAGE PIN FUNCTION	
FUNCTION	PIN
N/C	1
DIV 2/4/8	2
Lock Indicator Output	3
Phase Detector Output	4
Disable Input	5
N/C	6
Driver A Output	7
Driver B Output	8
Sense Amp Output	9
5V Ref Output	10
Loop Amp Inv Input	11
Loop Amp Output	12
Buffer Amp Input	13
Buffer Amp Output	14
+VIN	15
N/C	16
OSC Output	17
OSC Input	18
Ground	19
DIV 4/5 Input	20

**DIL-16, SOIC-16 (TOP VIEW)  
J or N Package, DW Package**

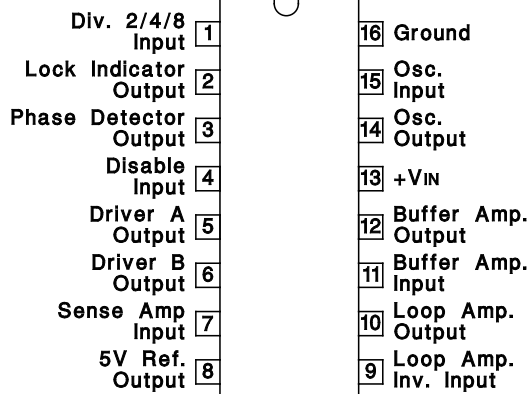

**ELECTRICAL CHARACTERISTICS:** Unless otherwise stated, these specifications apply for TA = 0°C to +70°C for the UC3634, -25°C to + 85°C for the UC2634 and -55°C to +125°C for the UC1634, +VIN = 12V. TA=TJ.

PARAMETERS	TEST CONDITIONS	MIN	TYP	MAX	UNITS
Supply Current	+VIN = 15V		20	29	mA
<b>Reference</b>					
Output Voltage (VREF)		4.75	5.0	5.25	V
Load Regulation	IOUT = 0mA to 7mA		5.0	20	mV
Line Regulation	+VIN = 8V to 15V		2.0	20	mV
Short Circuit Current	VOUT = 0V	12	30		mA
<b>Oscillator</b>					
DC Voltage Gain	Oscillator In to Oscillator Out	12	16	20	dB
Input DC Level (VIB)	Oscillator In Pin Open, TJ = 25°C	1.15	1.3	1.45	V
Input Impedance (Note 3)	VIN = VIB ± 0.5V, TJ = 25°C	1.3	1.6	1.9	kΩ
Output DC Level	Oscillator In Pin Open, TJ = 25°C	1.2	1.4	1.6	V
Maximum Operating Frequency		10			MHz
<b>Dividers</b>					
Maximum Input Frequency	Input = 1VPP at Oscillator In	10			MHz
Div. 4/5 Input Current (Q Package Only, Note 4)	Input = 5V (Div. by 4)		150	500	μA
	Input = 0V (Div. by 5)	-5.0	0.0	5.0	μA

**ELECTRICAL CHARACTERISTICS:** Unless otherwise stated, these specifications apply for  $T_A = 0^\circ\text{C}$  to  $+70^\circ\text{C}$  for the UC3634,  $-25^\circ\text{C}$  to  $+85^\circ\text{C}$  for the UC2634 and  $-55^\circ\text{C}$  to  $+125^\circ\text{C}$  for the UC1634,  $+V_{IN} = 12\text{V}$ .  $T_A = T_J$

PARAMETERS	TEST CONDITIONS	MIN	TYP	MAX	UNITS
<b>Dividers (cont.)</b>					
Div. 4/5 Input Threshold (Q Package Only, Note 4)		0.5	1.6	2.2	V
Div. 2/4/8 Input Current	Input = 5V (Div. by 8)		150	500	$\mu\text{A}$
	Input = 0V (Div. by 2)	-500	-150		$\mu\text{A}$
Div. 2/4/8 Open Current Voltage	Input Current = $0\mu\text{A}$ (Div. by 4)	1.5	2.5	3.5	V
Div. by 2 Threshold		0.20	0.8		V
Div. by 4 Threshold		1.5		3.5	V
Div. by 8 Threshold	Volts Below $V_{REF}$	0.20	0.8		V
<b>Sense Amplifier</b>					
Threshold Voltage	Percent of $V_{REF}$	27	30	33	%
Threshold Hysteresis			10		mV
Input Bias Current	Input = 1.5V	-1.0	-0.2		$\mu\text{A}$
<b>Two Phase Drive Outputs, A and B</b>					
Saturation Voltage	$I_{OUT} = 16\text{mA}$		0.3	0.6	V
Leakage Current	$V_{OUT} = 15\text{V}$		0.1	5.0	$\mu\text{A}$
<b>Disable Input</b>					
Input Current	Input = 5V (Disabled, A and B Outputs Active Low)		150	500	$\mu\text{A}$
	Input = 0V (Enabled)	-5.0	0.0	5.0	$\mu\text{A}$
Threshold Voltage		0.5	1.6	2.2	V
<b>Phase Detector</b>					
High Output Level	Positive Phase / Freq. Error, Volts Below $V_{REF}$		0.2	0.5	V
Low Output Level	Negative Phase / Freq. Error		0.2	0.5	V
Mid Output Level	Zero Phase / Freq. Error, Percent of $V_{REF}$	47	50	53	%
High Level Maximum Source Current	$V_{OUT} = 4.3\text{V}$	2.0	8.0		mA
Low Level Maximum Sink Current	$V_{OUT} = 0.7\text{V}$	2.0	5.0		mA
Mid Level Output Impedance (Note 3)	$I_{OUT} = -200$ to $+200\mu\text{A}$ , $T_J = 25^\circ\text{C}$	4.5	6.0	7.5	$\text{k}\Omega$
<b>Lock Indicator Output</b>					
Saturation Voltage	Freq. Error, $I_{OUT} = 5\text{mA}$		0.3	0.45	V
Leakage Current	Zero Freq. Error, $V_{OUT} = 15\text{V}$		0.1	1.0	$\mu\text{A}$
<b>Loop Amplifier</b>					
N INV. Reference Voltage	Percent of $V_{REF}$	47	50	53	%
Input Bias Current	Input = 2.5V	-0.8	-0.2		$\mu\text{A}$
AVOL		60	75		dB
PSRR	$+V_{IN} = 8\text{V}$ to $15\text{V}$	70	100		dB
Short Circuit Current	Source, $V_{OUT} = 0\text{V}$	16	35		mA
	Sink, $V_{OUT} = 5\text{V}$	16	30		mA
<b>Buffer Op-Amp</b>					
Input Offset Voltage	$V_{CM} = 2.5\text{V}$			8	mV
Input Bias Current	$V_{CM} = 2.5\text{V}$	-0.8	-0.2		$\mu\text{A}$
PSRR	$+V_{IN} = 8$ to $15\text{V}$	70	100		dB
CMRR	$V_{CM} = 0$ to $10\text{V}$	70	100		dB
Short Circuit Current	Source, $V_{OUT} = 0\text{V}$	16	35		mA
	Sink, $V_{OUT} = 5\text{V}$	16	30		mA

Note 3: These impedance levels will vary with  $T_J$  at about  $1700\text{ppm}/^\circ\text{C}$ .

Note 4: This part is also available in a 20 pin plastic leadless chip carrier, Q designator, where a divide by 4/5 select pin is available. Consult factory for details.

**APPLICATION AND OPERATION INFORMATION** (For additional information see UC1633 data sheet)

**Design Example:**

Precision phased locked frequency control of a 2-phase motor at 3600 RPM. Using the commutation logic on the UC3634, a simple discrete drive scheme is possible.

