

High Performance Stepper Motor Drive Circuit

FEATURES

- Full-Step, Half-Step and Micro-Step Capability.
- Bipolar Output Current up to 2A.
- Wide Range of Motor Supply Voltage: 10–50V
- Low Saturation Voltage
- Wide Range of Current Control: 5mA–2A.
- Current Levels Selected in Steps or Varied Continuously.
- Thermal Protection and Soft Intervention.

DESCRIPTION

The UC3770A and UC3770B are high-performance full bridge drivers that offer higher current and lower saturation voltage than the UC3717 and the UC3770. Included in these devices are LS-TTL compatible logic inputs, current sense, monostable, thermal shut-down, and a power H-bridge output stage. Two UC3770As or UC3770Bs and a few external components form a complete micro-processor-controllable stepper motor power system.

Unlike the UC3717, the UC3770A and the UC3770B require external high-side clamp diodes. The UC3770A and UC3770B are identical in all regards except for the current sense thresholds. Thresholds for the UC3770A are identical to those of the older UC3717 permitting drop-in replacement in applications where high-side diodes are not required. Thresholds for the UC3770B are tailored for half stepping applications where 50%, 71%, and 100% current levels are desirable.

The UC3770A and UC3770B are specified for operation from 0°C to 70°C ambient.

BLOCK DIAGRAM

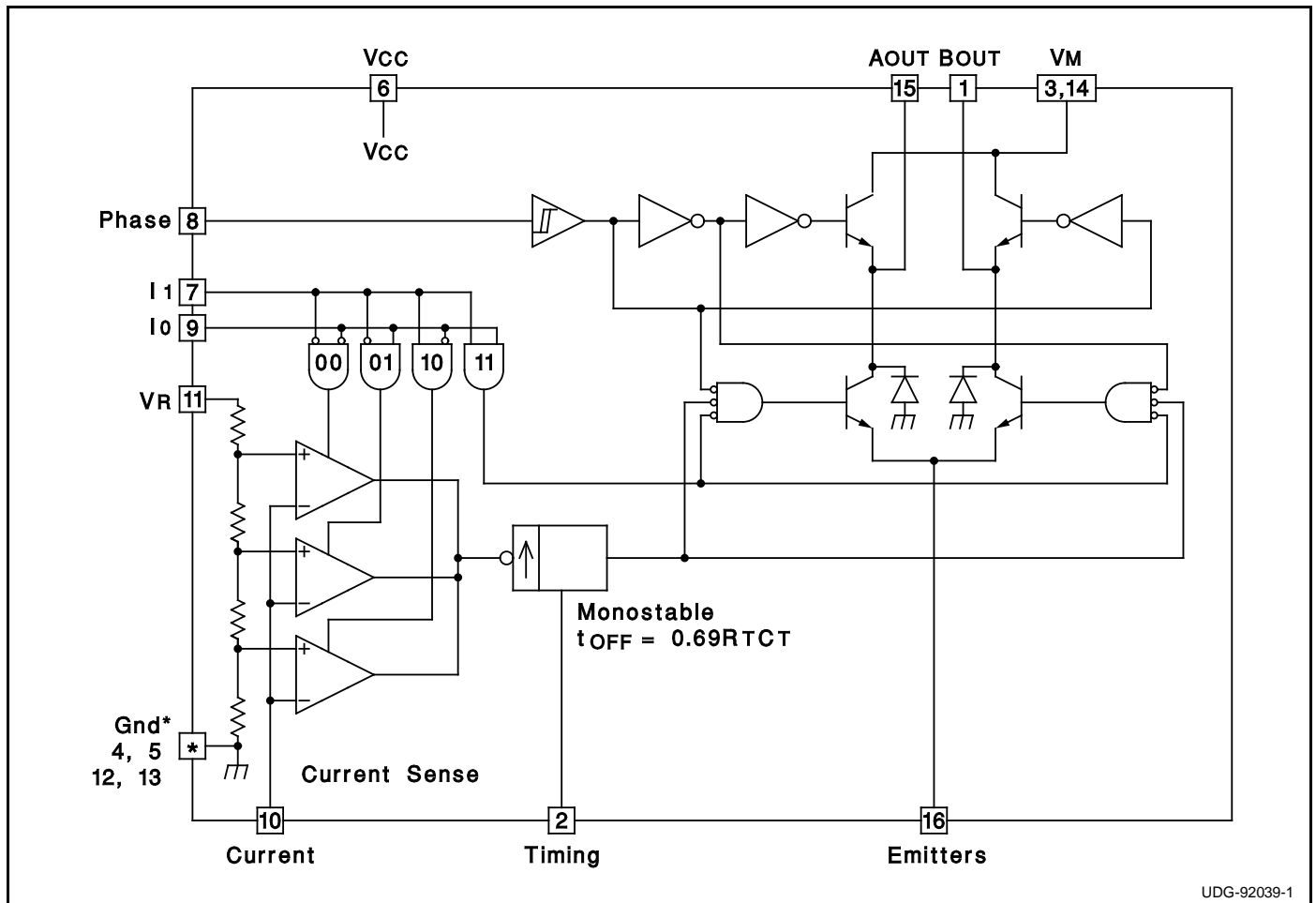

ABSOLUTE MAXIMUM RATINGS

| | |
|------------------------------------|--------|
| Logic Supply Voltage, Vcc | 7V |
| Output Supply Voltage, VMM | 50V |
| Logic Input Voltage (Pins 7, 8, 9) | 6V |
| Analog Input Voltage (Pin 10) | Vcc |
| Reference Input Voltage (Pin 11) | 15V |
| Logic Input Current (Pins 7, 8, 9) | -10mA |
| Analog Input Current (Pins 10, 11) | -10mA |
| Output Current (Pins 1, 15) | ± 2A |
| Junction Temperature, Tj | +150°C |

Note 1: All voltages are with respect to Gnd (DIL Pins 4, 5, 12, 13); all currents are positive into, negative out of the specified terminal.

Note 2: Consult Unitorde Integrated Circuits databook for thermal limitations and considerations of packages.

CONNECTION DIAGRAMS

**DIL-16 (Top View)
J Or N Package**

**PLCC-28 (Top View)
Q Package**

| PACKAGE PIN FUNCTION | |
|----------------------|-------|
| FUNCTION | PIN |
| Gnd | 1-3 |
| VM | 4 |
| N/C | 5 |
| AOUT | 6 |
| N/C | 7 |
| Emitters | 8 |
| Gnd | 9 |
| BOUT | 10 |
| Timing | 11 |
| VM | 12 |
| Gnd | 13-17 |
| Vcc | 18 |
| I1 | 19 |
| Phase | 20 |
| Io | 21 |
| N/C | 22 |
| Current | 23 |
| VR | 24 |
| N/C | 25-27 |
| Gnd | 28 |

ELECTRICAL CHARACTERISTICS: (All tests apply with VM = 36V, Vcc = 5V, VR = 5V, No Load, and 0°C < TA < 70°C, unless otherwise stated, TA = Tj.)

| PARAMETER | TEST CONDITIONS | UC3770A | | | UC3770B | | | UNITS |
|-----------------------------------|-------------------------|---------|------|------|---------|-----|------|-------|
| | | MIN | TYP | MAX | MIN | TYP | MAX | |
| Supply Voltage VM (Pins 3, 14) | | 10 | | 45 | 10 | | 45 | V |
| Logic Supply Voltage Vcc (Pin 6) | | 4.75 | 5 | 5.3 | 4.75 | 5 | 5.3 | V |
| Logic Supply Current Icc (Pin 6) | Io = I1 = H, Im = 0 | | 15 | 25 | | 15 | 25 | mA |
| | Io = I1 = L, Im = 0 | | 18 | 28 | | 18 | 28 | mA |
| | Io = I1 = H, Im = 1.3A | | 33 | 40 | | 33 | 40 | mA |
| Thermal Shutdown Temperature | | | +170 | | +170 | | | °C |
| Logic Threshold (Pins 7, 8, 9) | | 0.8 | | 2.0 | 0.8 | | 2.0 | V |
| Input Current Low (Pin 8) | Vi = 0.4V | | | -100 | | | -100 | µA |
| Input Current Low (Pins 7, 9) | Vi = 0.4V | | | -400 | | | -400 | µA |
| Input Current High (Pins 7, 8, 9) | Vi = 2.4V | | | 10 | | | 10 | µA |
| Comparator Threshold (Pin 10) | VR = 5V, Io = L, I1 = L | 400 | 415 | 430 | 400 | 415 | 430 | mV |
| | VR = 5V, Io = H, I1 = L | 240 | 255 | 265 | 290 | 300 | 315 | mV |
| | VR = 5V, Io = L, I1 = H | 70 | 80 | 90 | 195 | 210 | 225 | mV |
| Comparator Input Current (Pin 10) | | | | ±20 | | | ±20 | µA |
| Off Time | RT = 56k, CT = 820pF | 25 | 30 | 35 | 25 | 30 | 35 | ms |

ELECTRICAL CHARACTERISTICS (cont.):

(All tests apply with $V_M = 36V$, $V_{CC} = 5V$, $V_R = 5V$, No Load, and $0^\circ C < T_A < 70^\circ C$, unless otherwise stated, $T_A = T_J$.)

| PARAMETER | TEST CONDITIONS | UC3770A | | | UC3770B | | | UNITS |
|----------------------------------|-----------------|---------|-----|-----|---------|-----|-----|---------|
| | | MIN | TYP | MAX | MIN | TYP | MAX | |
| Turn Off Delay | | | | 2 | | | 2 | ms |
| Sink Driver Saturation Voltage | $I_M = 1.0A$ | | | 0.8 | | | 0.8 | V |
| | $I_M = 1.3A$ | | | 1.3 | | | 1.3 | V |
| Source Driver Saturation Voltage | $I_M = 1.0A$ | | | 1.3 | | | 1.3 | V |
| | $I_M = 1.3A$ | | | 1.6 | | | 1.6 | V |
| Output Leakage Current | $V_M = 45V$ | | | 100 | | | 100 | μA |

Figure 1: Typical Source Saturation Voltages vs. Load Current

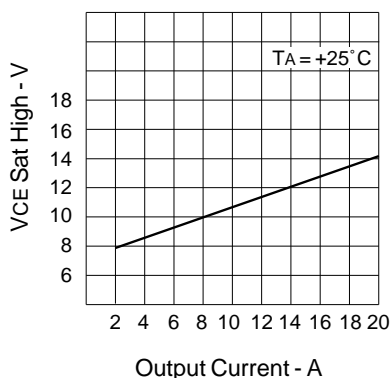

Figure 2: Typical Sink Saturation Voltages vs. Load Current

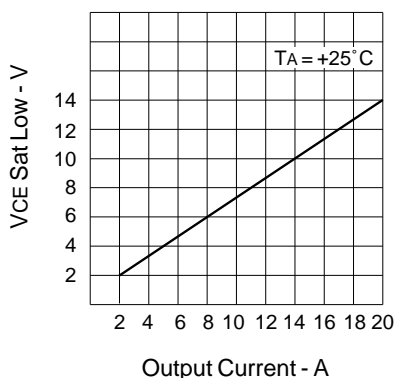

Figure 3: Typical Supply Current vs. Load Current

