

Single Cell Lithium-Ion Battery Protection Circuit

PRELIMINARY

FEATURES

- Protects Sensitive Lithium-Ion Cells From Over Charging and Over Discharging
- Dedicated for One Cell Applications
- Does Not Require External FETs or Sense Resistors
- Internal Precision Trimmed Charge and Discharge Voltage Limits
- Extremely Low Power Drain
- Low FET Switch Voltage Drop of 150mV Typical for 3A Currents
- Short Circuit Current Protection (with User Programmable Delay)
- 3A Current Capacity
- Thermal Shutdown
- User Controlled Enable Pin

DESCRIPTION

UCC3958 is a monolithic BCMOS lithium-ion battery protection circuit that is designed to enhance the useful operating life of one cell rechargeable battery packs. Cell protection features consist of internally trimmed charge and discharge voltage limits, discharge current limit with a delayed shutdown and an ultra low current sleep mode state when the cell is discharged. Additional features include an on chip MOSFET for reduced external component count and a charge pump for reduced power losses while charging or discharging a low cell voltage battery pack. This protection circuit requires a minimum number of external components and is able to operate and safely shutdown in the presence of a short circuit load.

BLOCK DIAGRAM

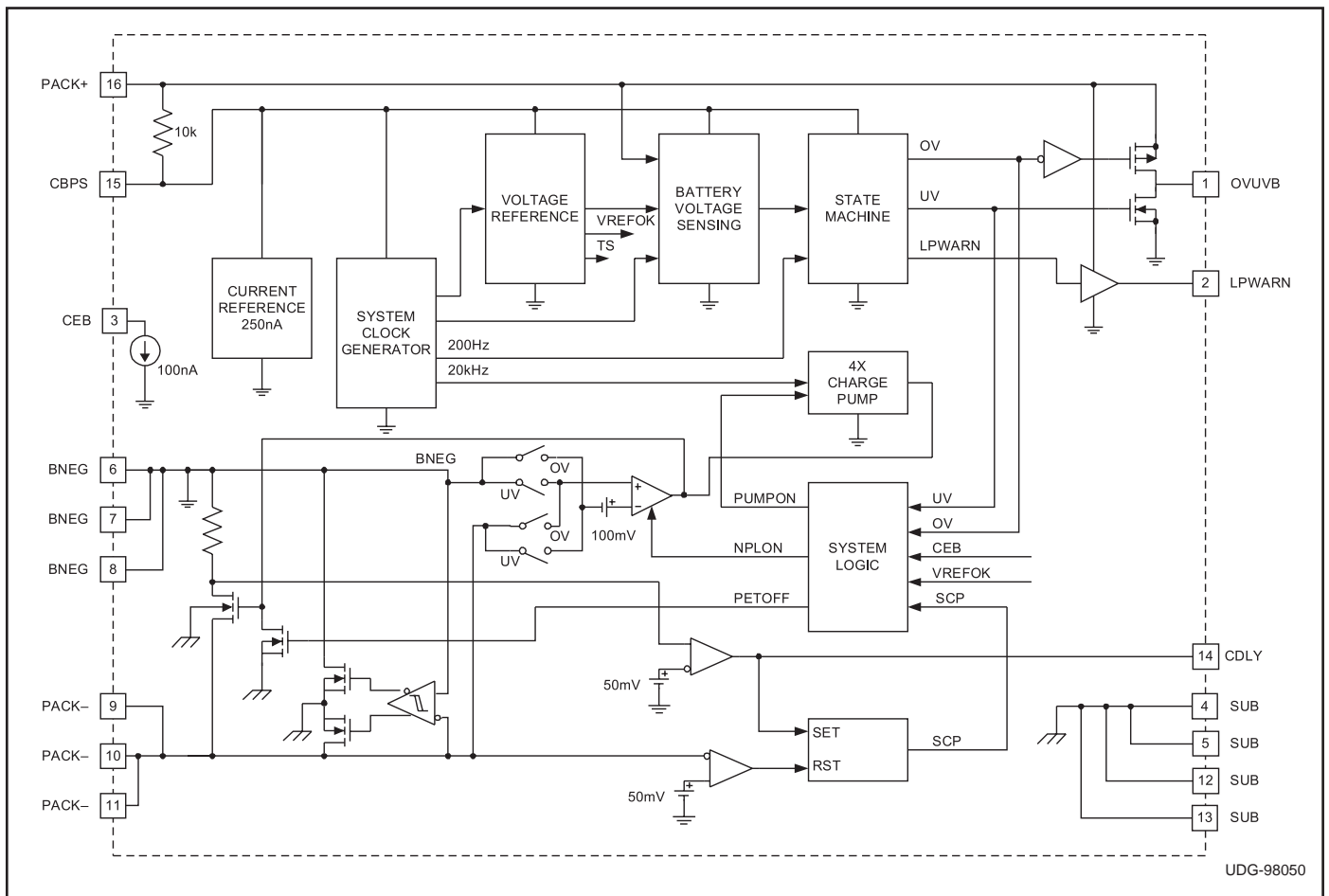

ABSOLUTE MAXIMUM RATINGS

Supply Voltage (PACK+ to BNEG) 7.5V
 Maximum Continuous Charge Current 3A
 Maximum Charger Voltage (PACK+ to PACK-) 9V
 Maximum Reverse Voltage (PACK+ to PACK-) -8V
 Storage Temperature -65°C to +150°C
 Junction Temperature -55°C to +150°C
 Lead Temperature (Soldering, 10 sec.) +300°C

*Currents are positive into, negative out of the specified terminal.
 Consult Packaging Section of Databook for thermal limitations and
 considerations of packages.*

CONNECTION DIAGRAMS

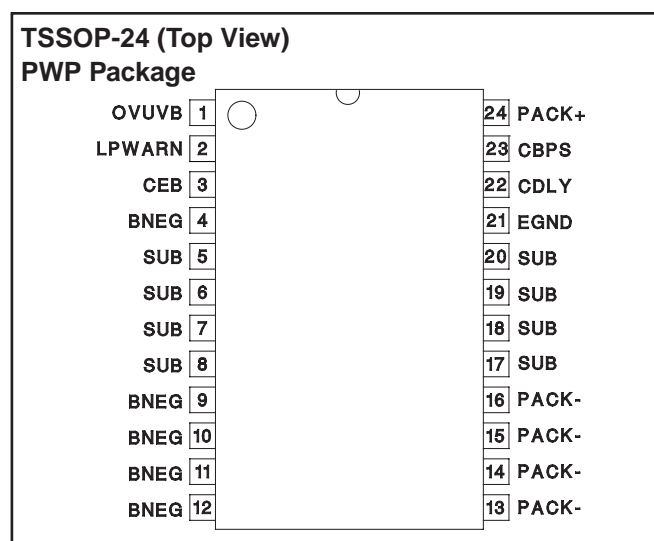
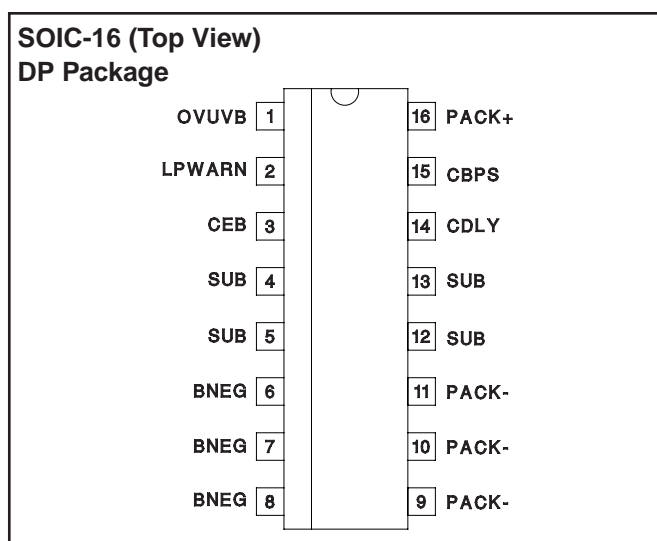

ELECTRICAL CHARACTERISTICS: Unless otherwise specified, PACK+ = 4V, -20°C < T_A < 70°C. All voltages measured with respect to BNEG. T_A = T_J.

PARAMETER	TEST CONDITIONS	MIN	TYP	MAX	UNITS
State Transition Thresholds					
NORM to OV (V _{OV})	UCC3958-1	4.15	4.20	4.25	V
OV to NORM (V _{THI})	UCC3958-1	3.85	3.90	3.95	V
NORM to OV (V _{OV})	UCC3958-2	4.20	4.25	4.30	V
OV to NORM (V _{THI})	UCC3958-2	3.90	3.95	4.00	V
NORM to OV (V _{OV})	UCC3958-3	4.25	4.30	4.35	V
OV to NORM (V _{THI})	UCC3958-3	3.95	4.00	4.05	V
NORM to OV (V _{OV})	UCC3958-4	4.30	4.35	4.40	V
OV to NORM (V _{THI})	UCC3958-4	4.00	4.05	4.10	V
NORM to UV (V _{UV})	(Note 1)	2.25	2.35	2.45	V
UV to NORM (V _{TLO})		2.55	2.65	2.75	V
OV, UV Delay Time (T _D)	All Dash Numbers	7	18	34	msec

ELECTRICAL CHARACTERISTICS: Unless otherwise specified, $V_{PACK+} = 4V$, $-20^{\circ}C < T_A < 70^{\circ}C$. All voltages measured with respect to BNEG. $T_A = T_J$.

PARAMETER	TEST CONDITIONS	MIN	TYP	MAX	UNITS
BNEG/PACK - SWITCH					
$V_{BNEG} - V_{PACK}$	NORM, $I_{SWITCH} = 2A$		-100	-150	mV
	NORM, $I_{SWITCH} = -2A$		100	150	mV
	$V_{PACK+} > V_{OV}$, $I_{SWITCH} = 20mA$ to $2A$, (OV State)		-100	-300	mV
	$V_{PACK+} = 2.5V$, $I_{SWITCH} = -20mA$ to $-2A$, (UV State)		100	600	mV
R_{DSon}	NORM $I_{SWITCH} = 2A$		50	75	m Ω
	NORM $I_{SWITCH} = -2A$		50	75	m Ω
I_{BNEG} – (Charger Leakage Current in OV)	$V_{PACK+} > V_{OV}$ (OV State) ($[V_{PACK+}] - [V_{PACK-}] = 6V$)		1	20	μA
BIAS Current					
I_{PACK+}	$V_{PACK+} > V_{UV}$		7	20	μA
I_{PACK+}	In Super Low Power Mode ($V_{PACK+} < V_{UV}$)		1	1.5	μA
V_{BAT}	Minimum Operating Cell Voltage			1.5	V
Battery Sample Rate (T_S)		7	12	17	ms
Short Circuit Protection					
ITHLD		2.75	5.25	7.25	A
TDLY	CDLY = 0		350		μs
	CDLY = 100pF (Maximum Recommended Value)		2.5		ms
R_{RESET}	Overcurrent Reset Resistance	7.5			M Ω
LPWARN Output					
LP Warn Threshold		2.55	2.65	2.75	V
TR	$C_{LOAD} = 100pF$, 10% to 90% of V_{PACK+}		280	560	ns
TF	$C_{LOAD} = 100pF$, 10% to 90% of V_{PACK+}		120	280	ns
V_{HIGH} ($V_{PACK+} - V_{LPWARN}$)	$I_{SINK} = 200\mu A$, $V_{UV} < V_{PACK+} < V_{TLO}$		0.3	0.4	V
V_{LOW}	$I_{SOURCE} = 200\mu A$, $V_{TLO} < V_{PACK+} < V_{UV}$		0.3	0.4	V
Measure Delay			6		ms
OVUVB Output					
TR	$C_{LOAD} = 100pF$, Hi Z to 90% of V_{PACK+}		280	560	ns
TF	$C_{LOAD} = 100pF$, Hi Z to 10% of V_{PACK+}		140	280	ns
V_{HIGH} ($V_{PACK+} - V_{OVUVB}$)	$I_{SOURCE} = 200\mu A$, $V_{PACK+} \geq V_{OV}$		0.3	0.4	V
V_{LOW}	$I_{SINK} = 200\mu A$, $V_{PACK+} \leq V_{UV}$		0.3	0.4	V
Z_{OUT}	Output Tristated		10		M Ω
Measure Delay			18		ms
CE Input					
I_{SINK}			150		nA

Note 1: Other threshold voltages are available.

PIN DESCRIPTIONS

BNEG: Connect the negative terminal of the battery to these pins.

CBPS: This power supply bypass pin is connected to PACK+ through an internal 10k resistor. An external capacitor must be connected between this pin and BNEG. This capacitor functions as temporary charge storage for high current conditions (short circuit). Minimum capacitor value is 0.15 μ F. This value should be increased if the CDLY cap is used.

CDLY: Delay control pin for the short circuit protection feature. A capacitor connected between this pin and the BNEG pin will increase the time delay for sensing an over current condition. This adjustment may be useful in those applications where high peak load currents may momentarily exceed the protection circuit's threshold and interruption of the battery current would be undesirable. The nominal delay time is set internally at 350 μ s

CEB: Chip Enable Bar. This pin is pulled low (wrt BNEG) by a 100nA current source. In order to disable the IC, the user must pull this pin high to PACK+.

LPWARN: Low Power Warning Indicator. This pin is forced high when the battery voltage drops below V_{TLO}

(nominally 2.65V). This pin will stay high until the detected battery voltage goes above V_{TLO} , or UV condition is declared.

OVUVB: This pin is an overvoltage/undervoltage condition indicator. Under normal operating conditions this pin is tristated. When an overvoltage (OV) state is detected, this pin is pulled high. When undervoltage (UV) condition is detected, this pin is pulled low.

PACK+: Connect to the positive terminal of the battery. This pin is available to the user.

PACK-: These pins should be connected to the negative terminal of the battery pack (negative terminal available to the user). The internal FET switch connects this terminal to the BNEG terminal to give the battery pack user appropriate access to the battery. In an overcharged state, only discharge current is permitted. In an overdischarged state, only charge current is permitted.

SUB: Do not connect. These pins must be electrically isolated from all other pins. These pins may be soldered to isolated copper pads for heatsinking. This will improve heat transfer, which may be necessary at high load currents.

APPLICATION INFORMATION

Battery Voltage Monitoring

The battery cell voltage is sampled every 12ms by connecting a resistor divider across it and comparing the resulting voltage to a precision internal reference voltage. Under normal conditions (cell voltage is below Over Voltage threshold and above Under Voltage threshold), the UCC3958 consumes approximately 7 μ A of current and the internal MOSFET is turned on with an R_{DSON} of 50m Ω . The UCC3958 contains an on-chip Charge Pump to ensure that the internal MOSFET gate is driven high for complete turn-on, reducing power losses. The charge pump switches and capacitors are all internal.

When the cell voltage falls below the Under Voltage threshold for two consecutive samples, the IC disconnects the load from the battery pack and enters a super low power mode (nominally 1 μ A). The pack will remain in this state until it detects the application of a charger, at which point controlled charging is enabled. The requirement of two consecutive readings below the UV threshold filters out momentary drops in cell voltage due to load transients, preventing nuisance trips.

If the cell voltage exceeds the Over Voltage threshold for two consecutive samples, charging is disabled, however discharge current is still allowed. This feature of the IC is explained further in the section on Controlled Charge/Discharge Mode.

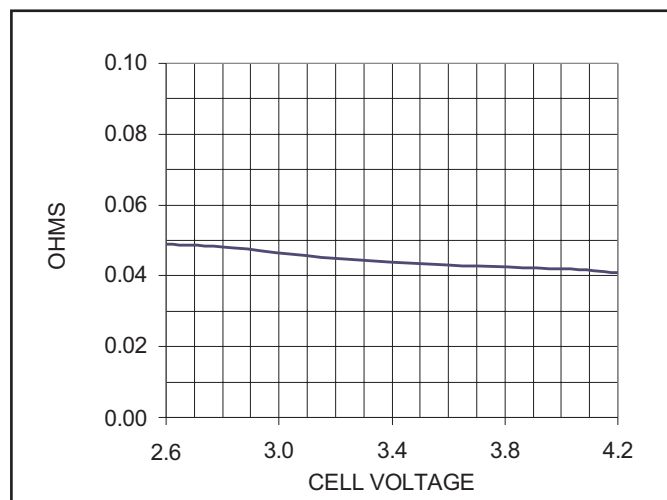

Figure 1. Typical Rdson vs Cell Voltage (DP Package Pin 7 to Pin 10, at 25°C, 1 Amp Load)

APPLICATION INFORMATION (continued)

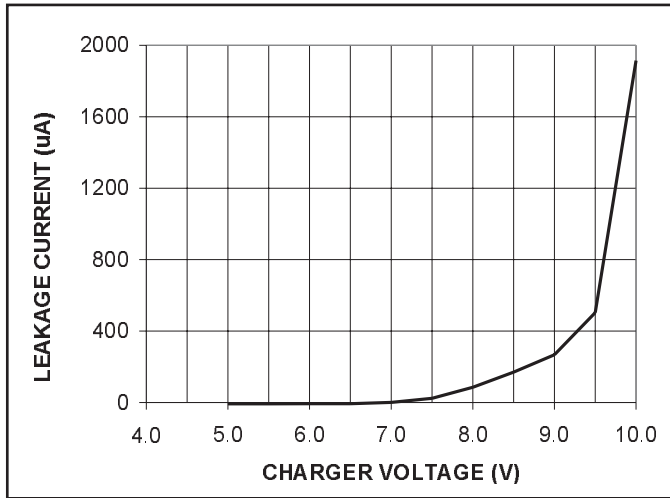

Figure 2. Typical OV Leakage Current with Runaway Charger at 25°C

Over Current Monitoring and Protection

Discharge current is continuously monitored via an internal sense resistor. In the event of excessive current, an Over Current condition is declared if the high current state persists for over 350µs. This delay allows for charging of the system bypass capacitors without tripping the overcurrent. A delay of 350µs guarantees that the pack can charge up to 680µF without declaring an Over Current condition. The delay may be extended to charge

larger load capacitors by connecting an external delay capacitor from the CDLY pin to one of the BNEG pins.

Once an Over Current condition has been declared, the internal MOSFET turns off. The only way to return the pack to normal operation is to remove the load by unplugging the pack from the system. The overcurrent is reset when an internal pull down brings PACK- to within less than 0.05V above BNEG. At this point, the pack returns to its normal state of operation. A capacitor on the CBPS pin provides momentary holdup for the UCC3958 to assure proper operation in the event that a hard short suddenly pulls the cell voltage below the minimum operating voltage. This cap value can be 0.15µF if the optional CDLY capacitor is not used. An internal 10k resistor buffers the bypass capacitor from the Li-Ion cell.

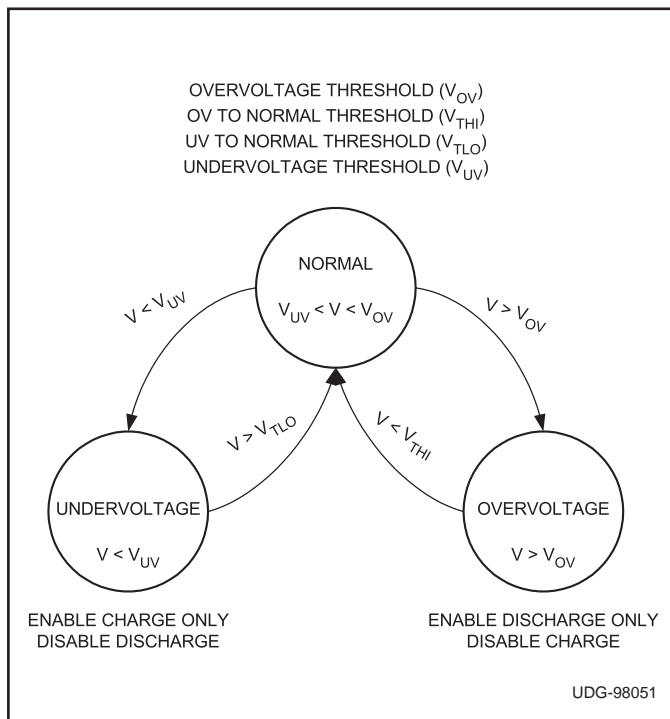

Figure 3. State Diagram

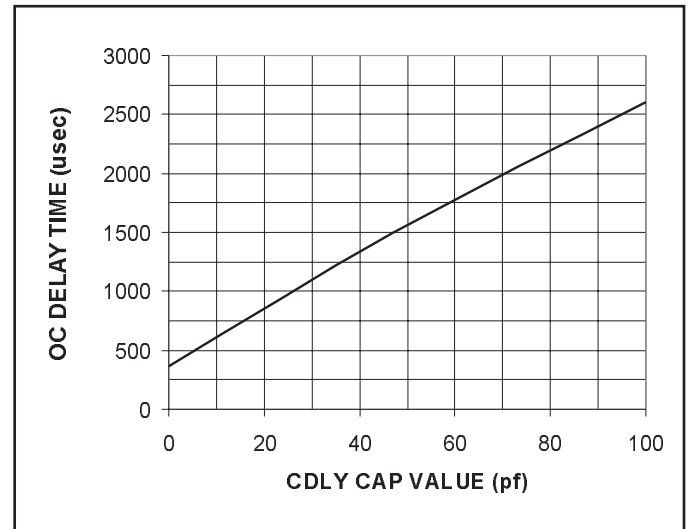

Figure 4. Typical Overcurrent Delay Time vs CDLY

System Status Indicators

The UCC3958 provides several convenient system monitoring signals. The first one is the Low Power Warning. This output goes high when the cell voltage is less than 300mV above the Under Voltage Threshold. It signals the system that the battery is getting close to its discharge limit.

The second monitoring signal is a tri-statable OV/UV output. Under normal operations conditions, this signal is tri-stated. When an Over Voltage condition is declared, the output is pulled high. When an Under Voltage condition is declared, the output is pulled low. This signal is especially useful during test, allowing easy verification of the OV and UV thresholds. These outputs are with respect to BNEG.

APPLICATION INFORMATION (continued)

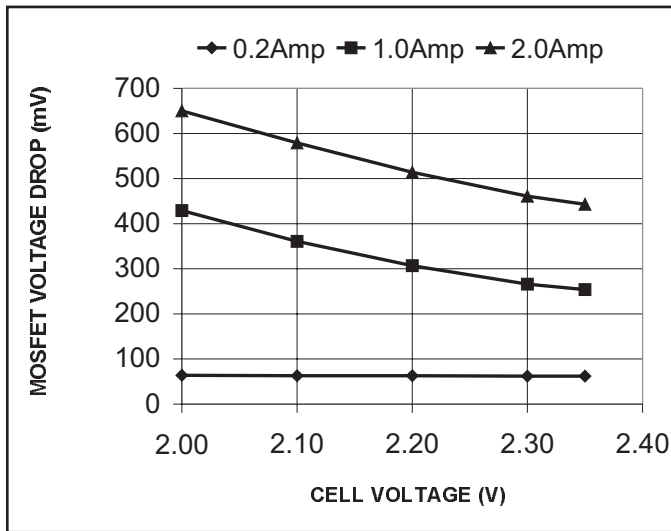

Figure 5. Typical MOSFET Voltage Drop During Charge in UV vs. Cell Voltage.

Controlled Charge/Discharge Mode

When the chip senses an over-voltage condition, it prevents any additional charging, but allows discharge. This is accomplished by activating a linear control loop which controls the gate of the MOSFET based on the differential voltage across its drain to source terminals. The linear loop attempts to regulate the differential voltage across the MOSFET to 100mV. When a light load is applied to the part, the loop adjusts the impedance of the MOSFET to maintain 100mV across it. As the load increases, the impedance of the MOSFET is decreased to maintain the 100mV control. At heavy loads (still below “over-current” limit level), the loop will not maintain regulation and will drive the gate of the MOSFET to the battery voltage (not the charge-pump output voltage). The MOSFET $R_{DS(ON)}$ in the over-voltage state will be slightly higher than $R_{DS(ON)}$ during normal operation. The voltage drop (and associated power loss) across the internal MOSFET in this mode of operation is lower than the typical solution of two external back-to-back MOSFETs, where the body diode is conducting.

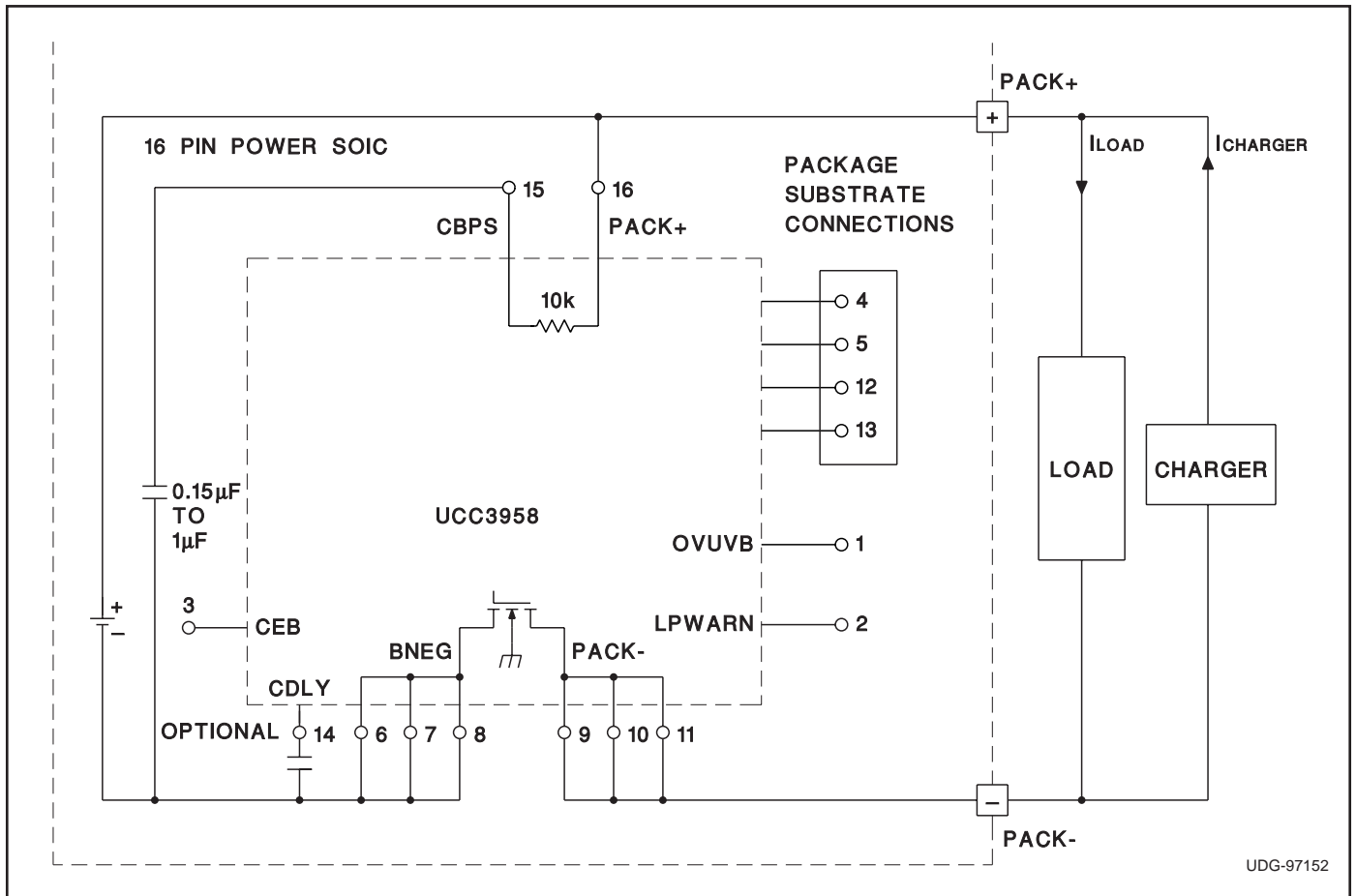

Figure 6. Single Cell Lithium-Ion Battery Protector IC Application Diagram

APPLICATION INFORMATION (continued)

When the chip senses an under-voltage condition, it disconnects the load from the battery pack and shuts itself down to minimize current drain from the battery. Several circuits remain powered and will detect placement of the battery pack into a charger. Once the charger presence is detected, the linear loop is activated and the chip al-

lows charging current into the battery. This linear control mode of operation is in effect until the battery voltage reaches a level 300mV above the under-voltage threshold, at which time normal operation is resumed.