

Half-Bridge Bipolar Switch

FEATURES

- Source or Sink 4.0A
- Supply Voltage to 35V
- High-Current Output Diodes
- Tri-State Operation
- TTL and CMOS Input Compatibility
- Thermal Shutdown Protection
- 300kHz Operation
- Low-Cost TO-220 Package

DESCRIPTION

This device is a monolithic integrated circuit designed to provide high-current switching with low saturation voltages when activated by low-level logic signals. Source and sink switches may be independently activated without regard to timing as a built-in interlock will keep the sink off if the source is on.

This driver has the high current capability to drive large capacitive loads with fast rise and fall times; but with high-speed internal flyback diodes, it is also ideal for inductive loads. Two UC2950s can be used together to form a full bridge, bipolar motor driver compatible with high frequency chopper current control.

ABSOLUTE MAXIMUM RATINGS (Note 1)

Supply Voltage Range, V_c	8V to 35V
Output Voltage Range, V_o	-3.0V to V_c+3V
Input Voltage Range, V_{IN}	-0.3V to +7.0V
Peak Output Current (100 ms, 10% DC)	$\pm 4.0A$
Continuous Output Current	$\pm 2.0A$
Power Dissipation with Heat Sink	15W
Power Dissipation in Free Air	2W
Operating Temperature Range, T_A	-20°C to +100°C
Storage Temperature Range, T_s	-55°C to +125°C

Note 1: Consult Packaging section of data-book for thermal limitations and considerations of package.

CONNECTION DIAGRAM

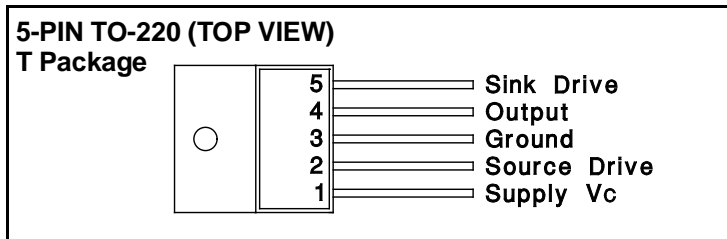

TRUTH TABLE

Source Drive Pin 2	Sink Drive Pin 5	Output Pin 4
Low	Low	Low
Low	High	Off
High	Low	High
High	High	High

Note: With no load, output voltage will be HIGH in the OFF state.

SIMPLIFIED SCHEMATIC

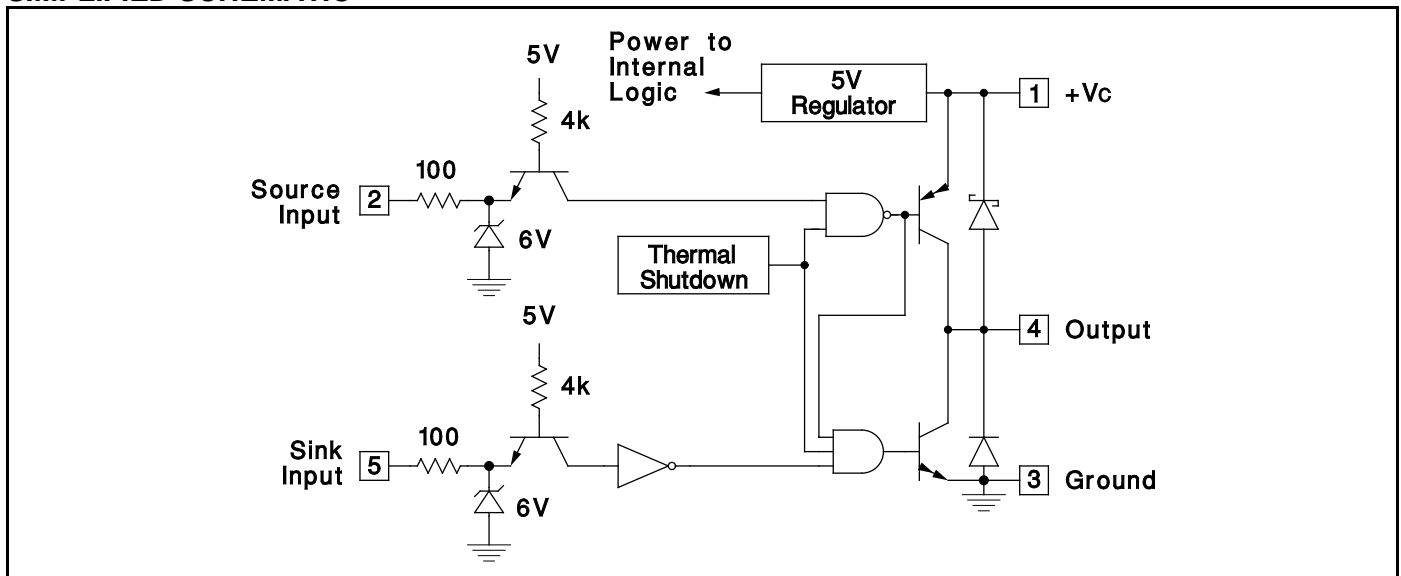

ELECTRICAL CHARACTERISTICS: Unless otherwise stated, $V_C = 35V$, $T_A = -20^{\circ}C$ to $+100^{\circ}C$, $V_{IL} = 0.8V$, $V_{IH} = 2.4V$ for either input, $T_A = T_J$.

PARAMETERS	TEST CONDITIONS	MIN	TYP	MAX	UNITS
Output Leakage to V_C	Output Off		20	500	μA
Output Leakage to Ground	Output Off		-200	-500	μA
Output Sink Saturation	V_{OL} , $I_L = 2.0A$		1.2	2.0	V
Output Source Saturation	$(V_C - V_{OL})$, $I_L = -2.0A$		1.2	2.0	V
Sink Diode Forward Voltage	$I_D = -2.0A$		1.4	2.0	V
Source Diode Forward Voltage	$I_D = 2.0A$		1.4 </td <td>2.0</td> <td>V</td>	2.0	V
Input Current	Either Input, $V_I = 5V$		20	100	μA
	Either Input, $V_I = 0V$		-1.0	-1.6	mA
Supply Current	Output High		20	30	mA
	Output Low		10	20	mA

SWITCHING CHARACTERISTICS: See Test Circuit. $V_C = 12V$, $R_L = 5\Omega$, $T_A = 25^{\circ}C$. Guaranteed by design, not 100% tested in production.

PARAMETERS	MIN	TYP	MAX	UNITS
Source Turn-On Delay, t_{D1}		300	500	ns
Source Turn-Off Delay, t_{D2}		1.0	2.0	μs
Sink Turn-On Delay, t_{D3}		200	400	ns
Sink Turn-Off Delay, t_{D4}		100	300	ns
Cross-Conduction Current Spike When Source and Sink are Activated Together		0.6	1.0	μs

SWITCHING TEST CIRCUIT

