



Programmable Voltage Clamp

FEATURES

- Shunt Regulator Keeps Power Supply Overtoltage to a Predetermined Level
- Programmable Input From 4.5V to 9V
- Internal 1.19V Floating Reference from VC Accurate to $\pm 4.2\%$
- Up to 17A Shunt Regulator Automatically Activated
- Gate Drive to External SCR Provided if Fault Persists
- Overtoltage Flag Available for Duration of Fault
- Requires Less Than $100\mu\text{A}$ in Standby Mode

DESCRIPTION

The UC3908 is a programmable voltage clamp designed to protect a power supply load in the event of an overvoltage. The UC3908 is a shunt regulator which, under an overvoltage condition, regulates the output voltage to programmed maximum value. It also provides a gate signal to an external SCR which crowbars the output if the shunted current exceeds a maximum value, if the chip's thermal shutdown circuitry is activated, or if the shunt regulator is saturated.

The UC3908 compares a divided down portion of the power supply output to an internal reference. If the output is below the trip point, the UC3908 remains in standby mode, draws less than $100\mu\text{A}$, and no action occurs. If the monitored voltage is above the trip point, the UC3908 shunts up to 17A of current to keep the output voltage within its prescribed limit and activates the FLAG signal. In effect the UC3908 acts as a dynamic filter to reduce power supply output voltage transients to acceptable levels. If the shunted current exceeds the maximum value, if chip junction temperature exceeds 165°C , or if the shunt transistor is saturated, a gate drive signal is sent to an external SCR to short circuit the output to ground. An internal latch is also activated to turn on the shunt transistor fully to minimize power dissipation under these conditions.

BLOCK DIAGRAM

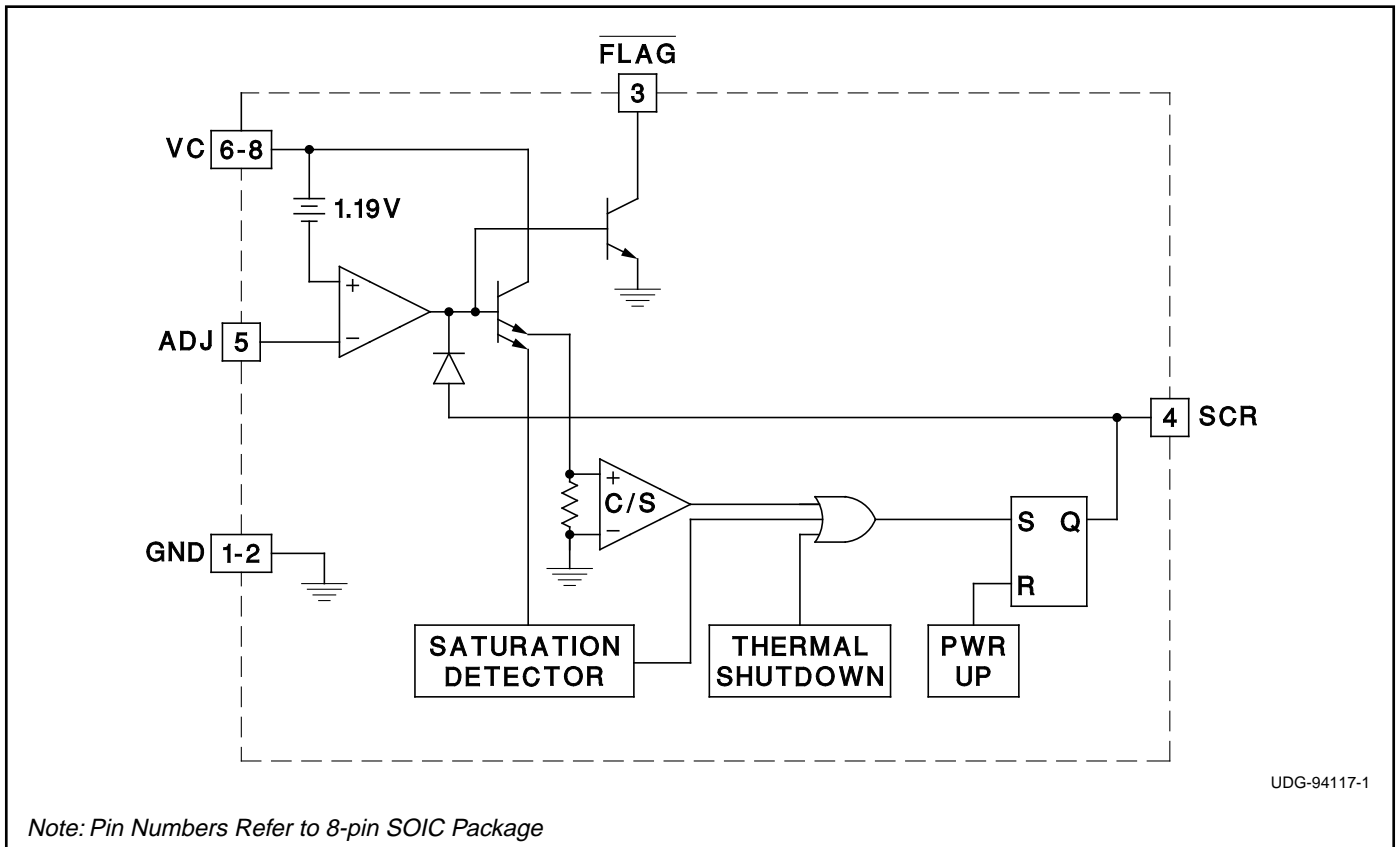

ABSOLUTE MAXIMUM RATINGS

Supply Voltage, VC9V
 Supply Current, Ivc20A
 Input Voltage Range-0.3V to 9V
 SCR/Latch Trip Current20A
 Storage Temperature-65°C to +150°C
 Operating Junction Temperature-55°C to +150°C
 Lead Temperature (Soldering, 10 sec.)+300°C
Unless otherwise indicated, voltages are referenced to ground and currents are positive into, negative out of, the specified terminal. Consult Packaging Section of Databook for thermal limitations and considerations of packages.

CONNECTION DIAGRAMS

**5-PIN TO-263 (FRONT VIEW)
TD PACKAGE**

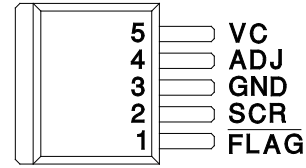

**SOIC-8 (TOP VIEW)
D PACKAGE**

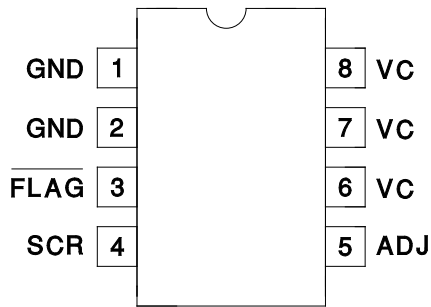

**5-PIN TO-220 (TOP VIEW)
T PACKAGE**

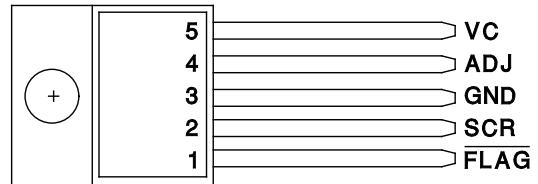

ELECTRICAL CHARACTERISTICS Unless otherwise stated these specifications apply for TA = -55°C to +125°C for UC1908; -40°C to +85°C for UC2908; and 0°C to +70°C for UC3908; VC = 9V with 10µF to GND, RSCR = 10k from SCR to GND, TA=TJ.

PARAMETER	TEST CONDITION	MIN	TYP	MAX	UNITS
VC Standby/Active		4.5		9	V
Ivc(Standby)	(VC - ADJ) ≤ (VREF - 50mV)		70	100	µA
IADJ (Standby)	(VC - ADJ) ≤ (VREF - 50mV)	-10	-2	+10	µA
IADJ (Active)	(VC - ADJ) = VREF (nominal)	-10	-1	+10	µA
VREF, Reference Voltage	Ivc = 30mA	1.14	1.19	1.24	V
Load Regulation ΔVREF/ΔIvc	30mA < Ivc < 8A, VC = 4.5V	-0.5		0.5	%/A
Line Regulation ΔVREF/ΔVC	4.5V < VC < 9V, Ivc = 30mA	-0.2		0.2	%/V
FLAG Sink Current (Active)	(VC - ADJ) = VREF (nominal)	0.5	4.0		mA
FLAG Saturation Voltage (Active)	(VC - ADJ) = VREF (nominal), Sink Current = 250µA		0.15	0.8	V
SCR/Latch Trip Current	TA = 25°C	14	17	20	A
	Over Temperature (Note 1)	10			A
SCR Output Resistance	ΔVSCR/ΔISCR, 20mA to 30mA	3	11	20	Ω
Thermal Shutdown	(Note 1)		165		°C

Note 1: Guaranteed by design. Not 100% tested in production.

PIN DESCRIPTIONS

ADJ: ADJ pin is used for the voltage divider from VC to set up the maximum VC value (VCmax) as calculated below. VREF, nominally 1.19V, is the reference voltage which controls the shunt regulator and whether the UC3908 is in its inactive (standby) or active state. When VC is less than

$$(V_{REF} - 50\text{mV}) \cdot \frac{(R1+R2)}{R1},$$

UC3908 is in the standby state. In this state, the device draws only 70µA and the shunt regulator is turned off. Above this point, as VC approaches

$$V_{REF} \cdot \frac{(R1+R2)}{R1} \text{ (or VCmax),}$$

the UC3908 smoothly transitions into its active state and controls the shunt regulator to maintain VC at this pre-programmed maximum voltage.

Referring to Figure 11, the resistor divider between VC and GND which forms the feedback control for ADJ is calculated as follows:

$$VC_{max} = V_{REF} \cdot \frac{(R1+R2)}{R1}$$

where the user selects one resistor value and VCmax and solves for the other resistor value. Since the signal at ADJ is compared to a VC referenced voltage, any voltage error induced by the shunt regulator and its ground return are eliminated from the feedback path.

FLAG: FLAG is an open collector output which becomes active low during an overvoltage condition. This pin can typically sink 1mA.

GND: This pin is the return point for all device currents. It carries the full current shunted by the UC3908.

SCR: The gate of an external SCR is connected to this pin. Normally, the SCR pin is in an inactive state (low). When active, the SCR pin is pulled to within 1V of VC. This pin then produces enough drive current to trigger the gate of the external SCR. Figure 10 illustrates the relationship between available gate current and the difference between Vc and the SCR pin voltage (Vc - VSCR). An external SCR is recommended to guarantee that the system stays at a safe shutdown voltage during a catastrophic fault until the system can be turned off and repaired. An external SCR is also needed for its ability to sink greater current levels at lower voltages than the UC3908 and to provide a clamp in a situation where the UC3908 can fail. The UC3908 fails open circuit.

VC: VC is the power input connection for this device. Its input range is from 4.5V to 9V. The quiescent VC current is typically 70µA when inactive, but the UC3908 can draw up to 17A when the shunt regulator is active. The instantaneous current is a function of the control loop sensing the changes at VC. VC is the reference point for the 1.19V reference.

APPLICATION INFORMATION

Protecting sensitive circuitry from power supply overvoltage conditions is a concern for any system designer. Overvoltage conditions can be caused by transient load changes, loss of the power supply control loop, accidental miswiring or incorrect module installation. An intelligent protection scheme can be accomplished utilizing the UC3908 programmable voltage clamp.

The UC3908 monitors a power supply output voltage and draws less than 100µA if no overvoltage condition is present. If an overvoltage condition occurs, the UC3908 will act as a shunt regulator and attempt to regulate the power supply to a programmed level by internally shunting current from VC to ground. An internal latch is activated and SCR signal is asserted under one of the following three conditions :

- (1) If the shunted current exceeds a maximum value, or
- (2) If the internal sense circuitry senses that the shunt transistor is saturated, or
- (3) If the overvoltage condition is of a long enough duration to trip the IC's internal thermal sense circuitry.

The SCR crowbars the power supply output , while the internal latch turns the shunt regulator fully on. The UC3908 also provides an overvoltage indicator signal (FLAG) through an open collector output any time an overvoltage condition occurs. The basic operation of the UC3908 is captured in the accompanying flowchart.

The UC3908 can be applied in an application with or without an external SCR. It is highly recommended that the external SCR be used in most applications excepting some low current applications. Due to its saturation voltage levels and thermal limitations, the UC3908 will not reliably provide overvoltage protection at high current levels. Its main purpose is to provide filtering against transient overvoltage situations which unnecessarily latch SCR crowbars in conventional circuits. The UC3908 allows the power supply to ride through these transients while still maintaining an acceptable level of voltage on the output.

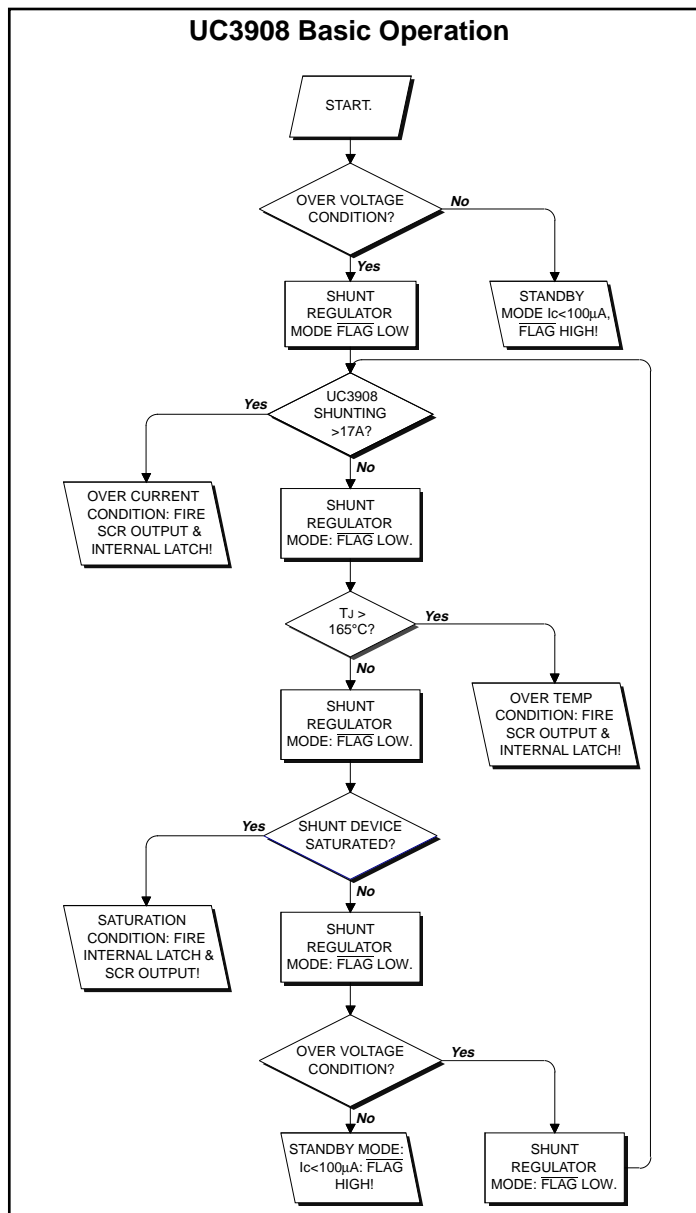

DESIGN CONSIDERATIONS

In a 5V output application, with total tolerance of $\pm 3\%$, the clamp circuit should not be active below 5.15V. When VC is less than

$$(V_{REF}(\min) - 50\text{mV}) \cdot \frac{(R1+R2)}{R1},$$

UC3908 is guaranteed to be inactive. With the worst case V_{REF} of 1.14V, $(R1+R2)/R1$ can be calculated to be 4.725. Selecting $R1$ to be 10k, $R2$ is calculated to be 37.25k and selected to be 37.4k. Under worst-case conditions, the regulated voltage will be

$$V_{REF}(\max) \cdot \frac{(R1+R2)}{R1}$$

which equals 5.877V in this case.

The lowest voltage that the UC3908 can regulate at is determined by the saturation voltage on the shunt transistor. This voltage is plotted in Figure 9 as a function of shunt current. In order to prevent an overvoltage situation, there is internal circuitry which senses when the shunt transistor reaches saturation and asserts the SCR output. In this case, the presence of an external SCR is an absolute necessity.

Another consideration required in designing a system with the UC3908 is the external SCR drive requirement. The drive signal provided by the UC3908 (on the SCR pin) is approximately 1V below the VC voltage at no load on SCR. In addition, there is an internal series power limiting resistance of approximately 11 ohms which contributes to additional voltage drop when required gate current is being supplied. In order to ensure that the external SCR is fired, a certain minimum gate voltage and minimum drive current must be provided by the drive circuit. The UC3908 is designed to provide 1.5V minimum gate voltage with a gate current of 75mA, which is sufficient to drive a wide range of SCRs. For higher output (VC) voltage levels, external series resistance may be needed to limit the power in the drive circuit. Also, in many applications, it may be necessary to include a bypass resistor from the gate to the cathode of the SCR to prevent false triggering due to noise. This resistor adds to the voltage drop through the UC3908 and must be taken into account when selecting the external SCR.

Figures 1 - 4 illustrate typical behavior of the UC3908 under different operating conditions. In Figure 1, the part is made to shunt less than 17A (6A, in this example) during a short overvoltage situation and thermal shutdown and saturation are also averted. In this case, the part is shown regulating VC at a preset level which is set at 5.59V in the given design example. The FLAG output is low during this mode and SCR output is not activated. I_c is pulsed back down to zero after some duration to indicate that the external pulse has disappeared and the UC3908 becomes inactive again.

In Figure 2, the overvoltage condition of Figure 1 is shown to persist long enough for the internal thermal shutdown to be activated. As a result, the SCR output is asserted and the internal latch is also activated. The voltage is shown falling to about 2V which is the saturation voltage for the UC3908 at this level of current (6A). With an external SCR, the VC voltage could have been pulled to a much lower level.

In Figure 3, the overvoltage condition results in the UC3908 sinking more than 17A of current in a short time. As a result, the overcurrent comparator activates

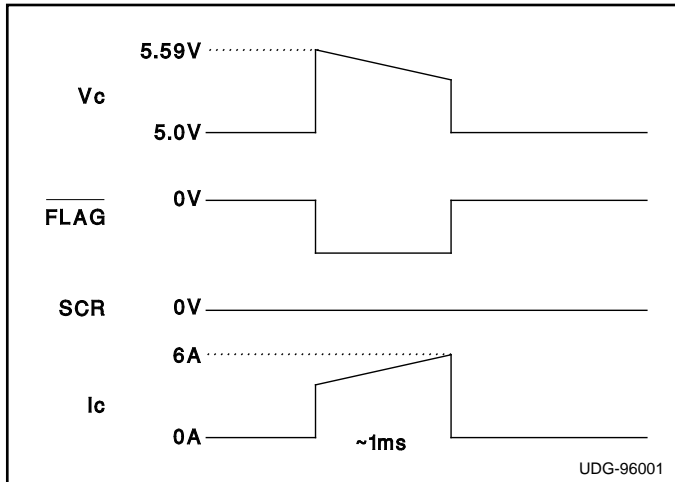

Figure 1. Shunt Regulation

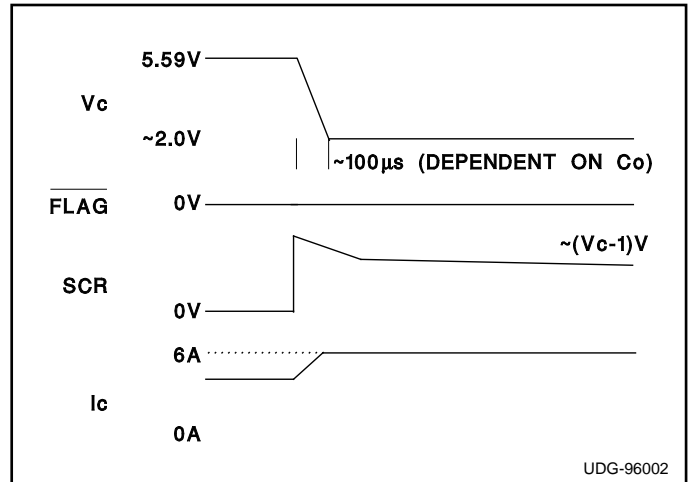

Figure 2. Thermal Shutdown

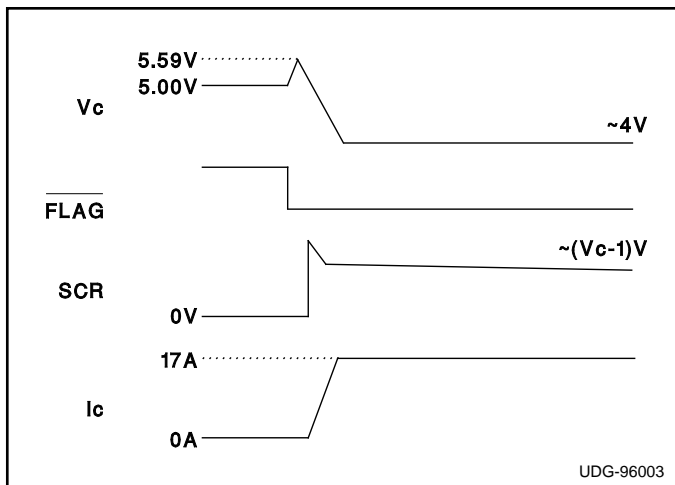

Figure 3. Overcurrent Shutdown

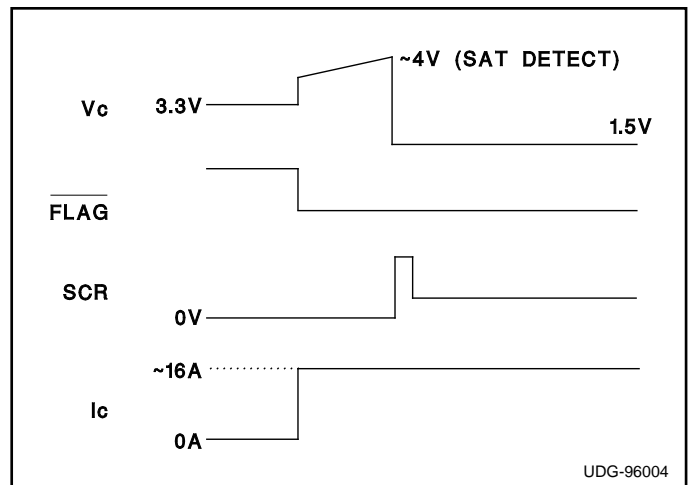

Figure 4. Saturation Detect Feature Resulting in External SCR Firing at Low VC Levels

the SCR output almost immediately after the $\overline{\text{FLAG}}$ is activated. Due to firing of the internal latch, VC drops out of regulation to the saturation level at the given I_c . In this situation, it is very desirable to have an external SCR for thermal reasons. The power dissipation at such a high current is extremely high and even though the UC3908 reduces voltage to reduce dissipation, its saturation voltage is high enough to cause excessive heating.

Finally, Figure 4 illustrates the effect of internal saturation detect circuitry. This circuitry is effective in preventing overvoltage situations at low values of regulated voltage and high current level. By looking at the characteristic curves for $V_c(\text{sat})$ at different levels as shown in Figure 9, it can be seen that the saturation voltage of the UC3908 shunt transistor can reach about 4V at 16A current levels. This will not help the part in regulating a 3.3V output, for example. The saturation detector senses the saturation level of the shunt transistor and activates the external SCR drive. Due to the asymmetrical nature of the current sharing in the shunt transistor, there may be

some overshoot of voltage before saturation is detected and external SCR is fired as shown in Figure 4.

THERMAL CONSIDERATIONS

The internal thermal shutdown circuit of the UC3908 is activated at approximately 165°C. The time taken to reach the thermal shutdown is inversely proportional to the power dissipation in the chip.

For short high power pulses or longer periods of moderate power levels, the UC3908 regulates the line at the programmed clamp voltage, shunting excess current to ground. Thus the UC3908 in effect filters voltage transients. For example, a UC3908 in a TO-220 package without any additional heatsinking and starting initially at 25°C takes approximately 1 second at 40 Watts of dissipation before triggering the thermal shutdown circuit. With a clip-on heatsink (e.g. Avid Engineering's clip on cooler for TO-220 packages rated at 5W, #574204B00000), thermal shutdown occurs after 4.7 seconds. At 90 Watts of dissipation thermal shutdown

occurs after 160ms, but with a heatsink it takes 210ms. At 100 Watts, the UC3908 shuts down in under 2ms with or without a heatsink. Under this condition the IC temperature is at 165°C, and an external SCR is required to protect the system and the UC3908. If an external SCR is not used and the UC3908 sets its internal latch from either overcurrent or thermal shutdown, the UC3908 will eventually burn up and fail open circuit.

At low power levels of any duration, the UC3908 regulates its input voltage at the programmed value. Low power levels are defined as any set of conditions (regulated voltage, shunt current, and heat sinking) which

keeps the internal thermal sense circuit below its overtemperature trigger point. For low power applications, the UC3908 will not require an external SCR. In the event of a temperature or overcurrent tripping the shutdown circuit, an internal latch drives the output transistor to sink as much current as possible. Thus, the UC3908 drops out of regulation. However, it also reduces the system voltage and hence reduces the overall power dissipated. A complete thermal analysis should be done to ensure the UC3908 can adequately dissipate the system power if an external SCR is not used.

TYPICAL CHARACTERISTICS CURVES

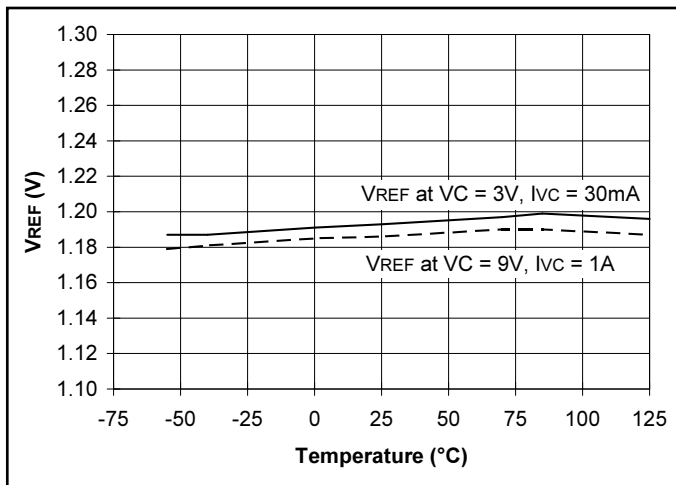

Figure 5. Reference vs. Temperature

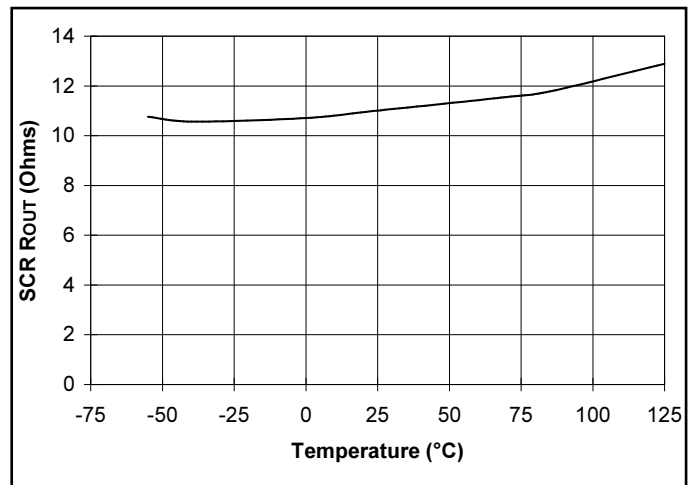

Figure 6. SCR Output Resistance

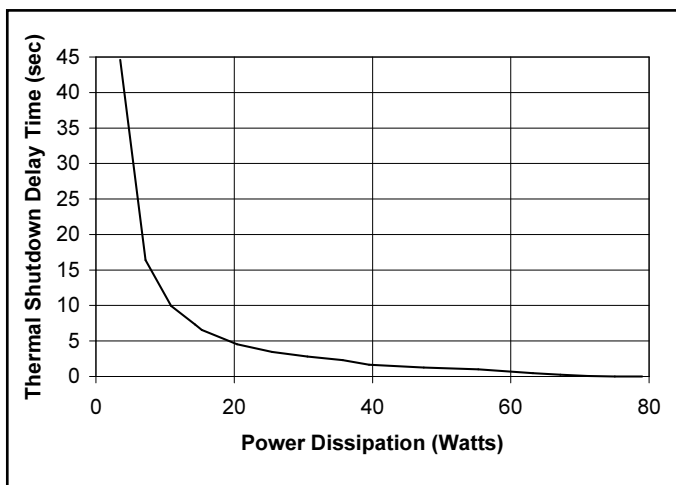

Figure 7. Thermal Shutdown Delay vs. Power Dissipation TO-220 Package (Without Any Heatsinking)

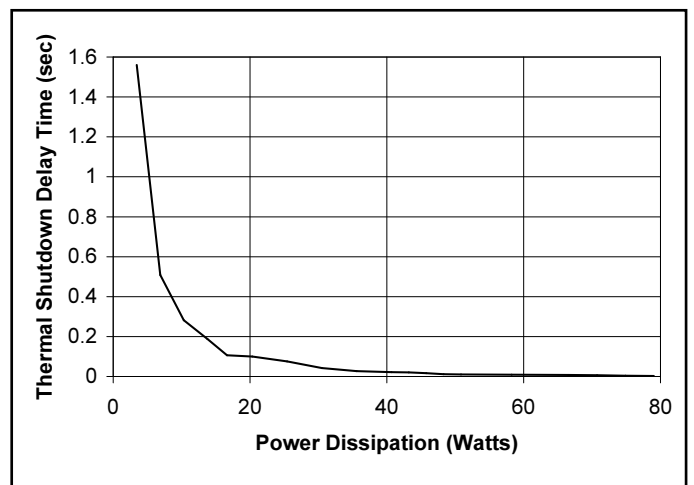

Figure 8. Thermal Shutdown Delay vs. Power Dissipation SOIC 8-Pin Package (Without Any Heatsinking)

TYPICAL CHARACTERISTICS CURVES (cont.)

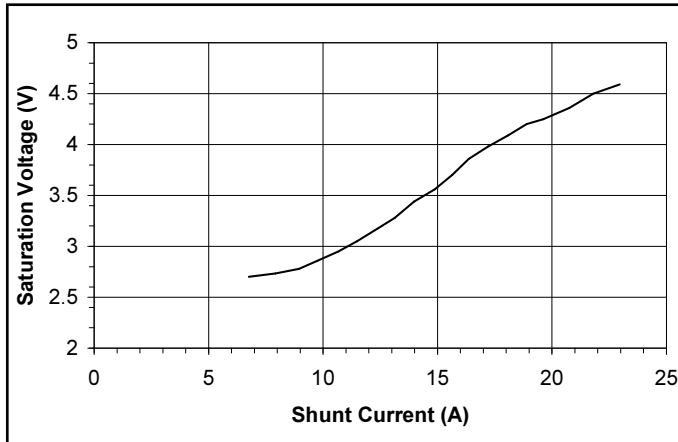

Figure 9. Typical Saturation Characteristics of the Shunt Transistor

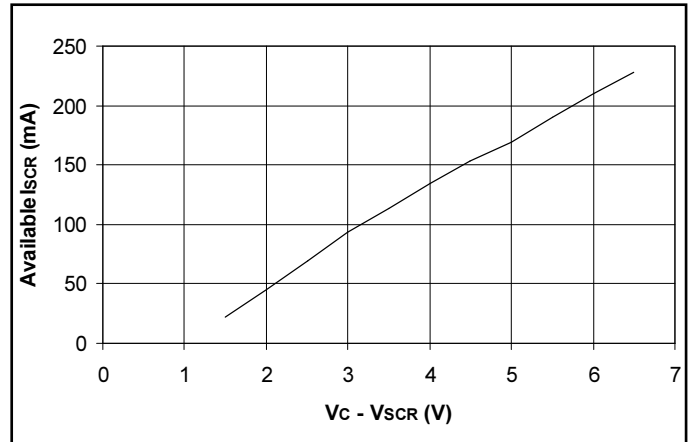

Figure 10. SCR Drive Current Characteristics

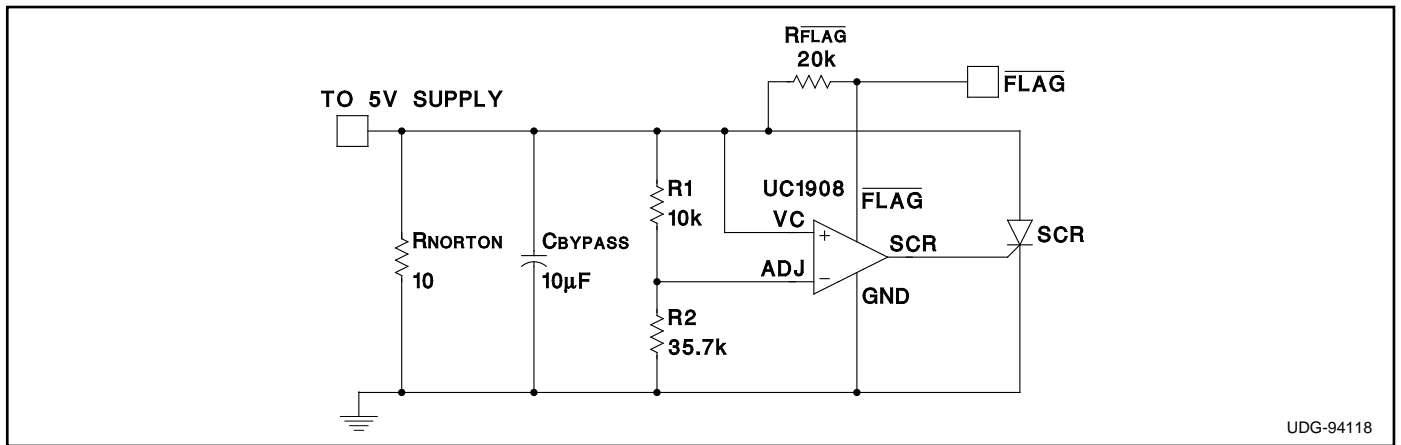

Figure 11. 5.2V Clamp Protection for 5V System with an External SCR

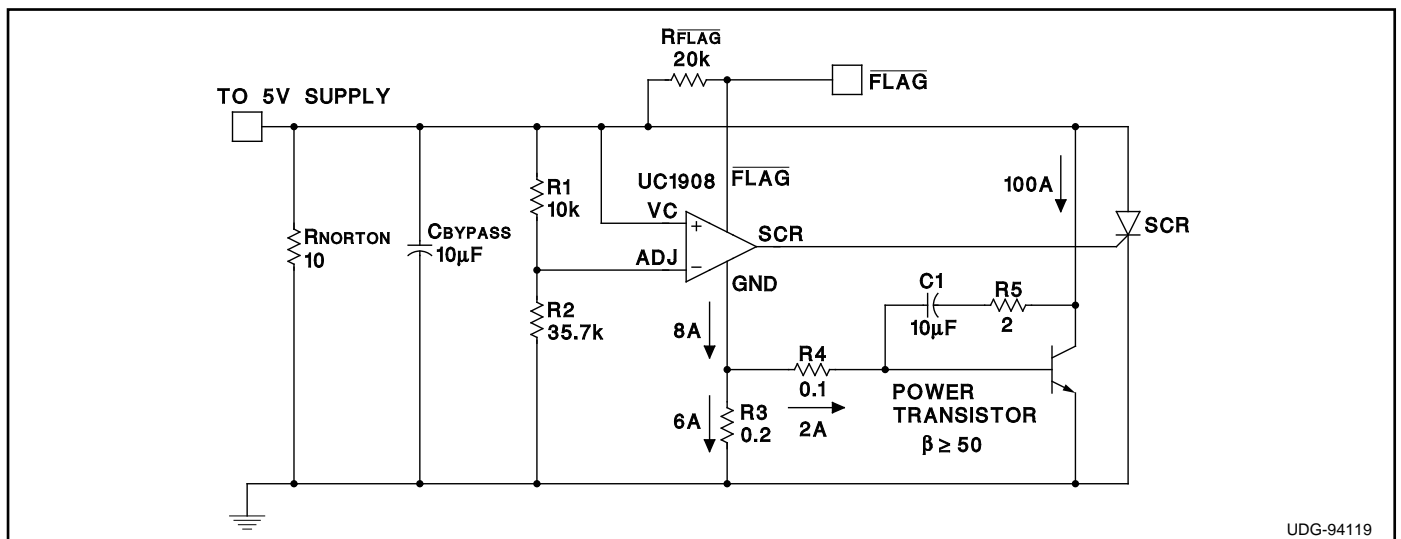

Figure 12. Greater Than 100A Protection Application