

Single Ended Active Clamp/Reset PWM

FEATURES

- Provides Auxiliary Switch Activation Complementary to Main Power Switch Drive
- Programmable deadtime (Turn-on Delay) Between Activation of Each Switch
- Voltage Mode Control with Feedforward Operation
- Programmable Limits for Both Transformer Volt-Second Product and PWM Duty Cycle
- High Current Gate Driver for Both Main and Auxiliary Outputs
- Multiple Protection Features with Latched Shutdown and Soft Restart
- Low Supply Current (100µA Startup, 1.5mA Operation)

DESCRIPTION

The UCC3580 family of PWM controllers is designed to implement a variety of active clamp/reset and synchronous rectifier switching converter topologies. While containing all the necessary functions for fixed frequency, high performance pulse width modulation, the additional feature of this design is the inclusion of an auxiliary switch driver which complements the main power switch, and with a programmable deadtime or delay between each transition. The active clamp/reset technique allows operation of single ended converters beyond 50% duty cycle while reducing voltage stresses on the switches, and allows a greater flux swing for the power transformer. This approach also allows a reduction in switching losses by recovering energy stored in parasitic elements such as leakage inductance and switch capacitance.

The oscillator is programmed with two resistors and a capacitor to set switching frequency and maximum duty cycle. A separate synchronized ramp provides a voltage feedforward pulse width modulation and a programmed maximum volt-second limit. The generated clock from the oscillator contains both frequency and maximum duty cycle information.

The main gate drive output (OUT1) is controlled by the pulse width modulator. The second output (OUT2) is intended to activate an auxiliary switch during the off time of the main switch, except that between each transition there is deadtime where both switches are off, programmed by a single external resistor. This design offers two options for OUT2, normal and inverted. In the -1 and -2 versions, OUT2 is normal and can be used to drive PMOS FETs. In the -3

BLOCK DIAGRAM

continued

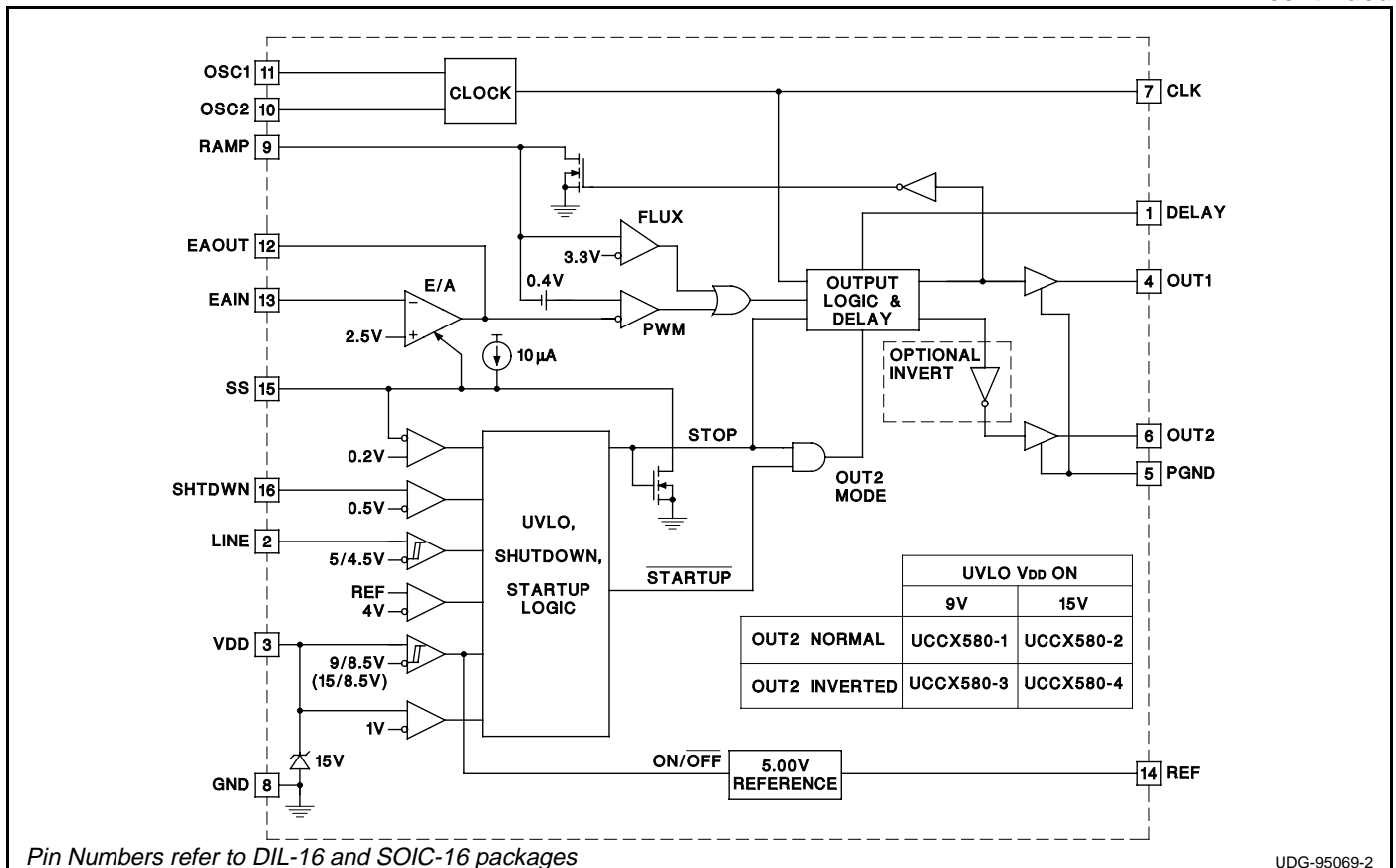

DESCRIPTION (cont.)

and -4 versions, OUT2 is inverted and can be used to drive NMOS FETs. In all versions, both the main and auxiliary switches are held off prior to startup and when the PWM command goes to zero duty cycle. During fault conditions, OUT1 is held off while OUT2 operates at maximum duty cycle with a guaranteed off time equal to the sum of the two deadtimes.

Undervoltage lockout monitors supply voltage (VDD), the precision reference (REF), input line voltage (LINE), and the shutdown comparator (SHTDWN). If after any of these four have sensed a fault condition, recovery to full operation is initiated with a soft start. VDD thresholds, on and off, are 15V and 8.5V for the -2 and -4 versions, 9V and 8.5V for the -1 and -3 versions.

ABSOLUTE MAXIMUM RATINGS

VDD	16V
IVDD	25mA
LINE, RAMP	-0.3V to VDD + 1V
I _{LINE} , I _{RAMP}	5mA
DELAY	5.3V
IDELAY	-5mA
I _{OUT1} (tpw < 1μs and Duty Cycle < 10%)	-0.6A to 1.2A
I _{OUT2} (tpw < 1μs and Duty Cycle < 10%)	-0.4A to 0.4A
I _{CLK}	-100mA to 100mA
OSC1, OSC2, SS, SHTDWN, EAIN	-0.3V to REF + 0.3V
I _{EAOUT}	-5mA to 5mA
I _{REF}	-30mA
PGND	-0.2V to 0.2V
Storage Temperature	-65°C to +150°C
Junction Temperature	-55°C to +150°C
Lead Temperature (Soldering, 10 sec.)	+300°C

All voltages are with respect to ground unless otherwise stated. Currents are positive into, negative out of the specified terminal. Consult Packaging Section of Databook for thermal limitations and considerations of packages.

ORDER INFORMATION



ELECTRICAL CHARACTERISTICS Unless otherwise stated, all specifications are over the full temperature range, VDD = 12V, R1 = 18.2k, R2 = 4.41k, C_T = 100pF, R3 = 100k, C_{OUT1} = 0, C_{OUT2} = 0. T_A = 0°C to 70°C for the UCC3580, -40°C to 85°C for the UCC2580, -55°C to 125°C for the UCC1580, T_A = T_J.

PARAMETER	TEST CONDITIONS	MIN	TYP	MAX	UNITS
Oscillator Section					
Frequency		370	400	430	kHz
CLK Pulse Width		650	750	850	ns
CLK V _{OH}	I _{CLK} = -3mA	4.3	4.7		V
CLK V _{OL}	I _{CLK} = 3mA		0.3	0.5	V

The UCC1580-x is specified for operation over the military temperature range of -55°C to 125°C. The UCC2580-x is specified from -40°C to 85°C. The UCC3580-x is specified from 0°C to 70°C. Package options include 16-pin surface mount or dual in-line, and 20-pin plastic leadless chip carrier.

Prospective users of this IC are advised that, while use in certain applications could potentially violate patent rights of one or more third parties, this product has been licensed for use in flyback power supply applications as described by U.S. Patent 5,402,329 from Technical Witts, Inc. Unitrode disclaims any other liability and suggests that users consult their own legal advisors.

CONNECTION DIAGRAMS

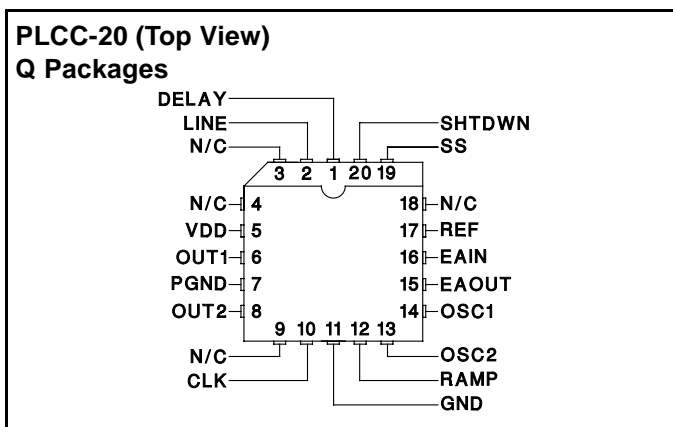
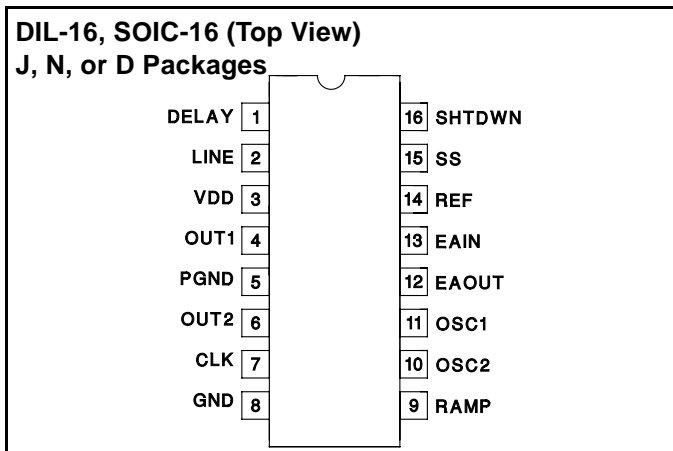

ELECTRICAL CHARACTERISTICS (cont.) Unless otherwise stated, all specifications are over the full temperature range, VDD = 12V, R1 = 18.2k, R2 = 4.41k, CT = 100pF, R3 = 100k, COUT1 = 0, COUT2 = 0. TA = 0°C to 70°C for the UCC3580, -40°C to 85°C for the UCC2580, -55°C to 125°C for the UCC1580, TA = TJ.

PARAMETER	TEST CONDITIONS	MIN	TYP	MAX	UNITS
Ramp Generator Section					
Ramp VOL	IRAMP = 100 μ A		50	100	mV
Flux Comparator Vth		3.16	3.33	3.50	V
Pulse Width Modulator Section					
Minimum Duty Cycle	OUT1, EAOUT = VOL			0	%
Maximum Duty Cycle	OUT1, EAIN = 2.6V	63	66	69	%
PWM Comparator Offset		0.1	0.4	0.9	V
Error Amplifier Section					
EAIN	EAOUT = EAIN	2.44	2.5	2.56	V
IEAIN	EAOUT = EAIN		150	400	nA
EAOUT, VOL	EAIN = 2.6V, IEAOUT = 100 μ A		0.3	0.5	V
EAOUT, VOH	EAIN = 2.4V, IEAOUT = -100 μ A	4	5	5.5	V
AVOL		70	80		dB
Gain Bandwidth Product	f = 100kHz (Note 1)	2	6		MHz
Softstart/Shutdown Section					
Start Duty Cycle	EAIN = 2.4V		0		%
SS VOL	Iss = 100 μ A		100	350	mV
SS Restart Threshold			400	550	mV
Iss			-20	-35	μ A
SHTDWN Vth		0.4	0.5	0.6	V
ISHTDWN			50	150	nA
Undervoltage Lockout Section					
VDD On	UCC3580-2,-4	14	15	16	V
	UCC3580-1,-3	8	9	10	V
VDD Off		7.5	8.5	9.5	V
LINE On		4.7	5	5.3	V
LINE Off		4.2	4.5	4.8	V
ILINE	LINE = 6V		50	150	nA
Supply Section					
VDD Clamp	IvDD = 10mA	14	15	16	V
IvDD Start	VDD < VDD On		160	250	μ A
IvDD Operating	No Load		2.5	3.5	mA
Output Drivers Section					
OUT1 VSAT High	IOUT1 = -50mA		0.4	1.0	V
OUT1 VSAT Low	IOUT1 = 100mA		0.4	1.0	V
OUT2 VSAT High	IOUT2 = -30mA		0.4	1.0	V
OUT2 VSAT Low	IOUT2 = 30mA		0.4	1.0	V
OUT1 Fall Time	COUT1 = 1nF, Rs = 3 Ω		20	50	ns
OUT1 Rise Time	COUT1 = 1nF, Rs = 3 Ω		40	80	ns
OUT2 Fall Time	COUT2 = 300pF, Rs = 10 Ω		20	50	ns
Output Drivers Section (cont.)					
OUT2 Rise Time	COUT2 = 300pF, Rs = 10 Ω		20	40	ns
Delay 1 OUT2 to OUT1	R3 = 100k, COUT1 = COUT2 = 15pF	90	120	160	ns
	TA = TJ = 25°C	100	120	140	ns
Delay 2 OUT1 to OUT2	R3 = 100k, COUT1 = COUT2 = 15pF	110	170	250	ns
	TA = TJ = 25°C	140	170	200	ns

ELECTRICAL CHARACTERISTICS (cont.): Unless otherwise stated, all specifications are over the full temperature range, VDD = 12V, R1 = 18.2k, R2 = 4.41k, CT = 100pF, R3 = 100k, COUT1 = 0, COUT2 = 0. TA = 0°C to 70°C for the UCC3580, -40°C to 85°C for the UCC2580, -55°C to 125°C for the UCC1580, TA = TJ.

PARAMETER	TEST CONDITIONS	MIN	TYP	MAX	UNITS
Reference Section					
REF	IREF = 0	4.875	5	5.125	V
Load Regulation	IREF = 0mA to 1mA		1	20	mV
Line Regulation	VDD = 10V to 14V		1	20	mV

Note 1: Guaranteed by design. Not 100% tested in production.

PIN DESCRIPTIONS

CLK: Oscillator clock output pin from a low impedance CMOS driver. CLK is high during guaranteed off time. CLK can be used to synchronized up to five other UCC3580 PWMs.

DELAY: A resistor from DELAY to GND programs the nonoverlap delay between OUT1 and OUT2. The delay times, Delay1 and Delay2, are shown in Figure 1 and are as follows:

$$\text{Delay 1} = 1.1\text{pF} \cdot R3.$$

Delay 2 is designed to be larger than Delay 1 by a ratio shown in Figure 2.

EAIN: Inverting input to the error amplifier. The noninverting input of the error amplifier is internally set to 2.5V. EAIN is used for feedback and loop compensation.

EAOUT: Output of the error amplifier and input to the PWM comparator. Loop compensation components connect from EAOUT to EAIN.

GND: Signal Ground.

LINE: Hysteretic comparator input. Thresholds are 5.0V and 4.5V. Used to sense input line voltage and turn off OUT1 when the line is low.

OSC1 & OSC2: Oscillator programming pins. A resistor connects each pin to a timing capacitor. The resistor connected to OSC1 sets maximum on time. The resistor connected to OSC2 controls guaranteed off time. The combined total sets frequency with the timing capacitor. Frequency and maximum duty cycle are approximately given by:

$$\text{Frequency} = \frac{1}{(R1 + 1.25 \cdot R2) \cdot C_T}$$

$$\text{Maximum Duty Cycle} = \frac{R1}{R1 + 1.25 \cdot R2}$$

Maximum Duty Cycle for OUT1 will be slightly less due to Delay1 which is programmed by R3.

OUT1: Gate drive output for the main switch capable of sourcing up to 0.5A and sinking 1A.

OUT2: Gate drive output for the auxiliary switch with $\pm 0.3\text{A}$ drive current capability.

PGND: Ground connection for the gate drivers. Connect PGND to GND at a single point so that no high frequency components of the output switching currents are in the ground plane on the circuit board.

RAMP: A resistor (R4) from RAMP to the input voltage and a capacitor (CR) from RAMP to GND programs the feedforward ramp signal. RAMP is discharged to GND when CLK is high and allowed to charge when CLK is low. RAMP is the line feedforward sawtooth signal for the PWM comparator. Assuming the input voltage is much greater than 3.3V, the ramp is very linear. A flux comparator compares the ramp signal to 3.3V to limit the maximum allowable volt-second product:

$$\text{Volt-Second Product Clamp} = 3.3 \cdot R4 \cdot CR.$$

REF: Precision 5.0V reference pin. REF can supply up to 5mA to external circuits. REF is off until VDD exceeds 9V (-1 and -3 versions) or activates the 15V clamp (-2 and -4 versions) and turns off again when VDD droops below 8.5V. Bypass REF to GND with a 1 μF capacitor.

SHTDWN: Comparator input to stop the chip. The threshold is 0.5V. When the chip is stopped, OUT1 is low and OUT2 continues to oscillate with guaranteed off time equal to two non-overlap delay times.

SS: A capacitor from SS to ground programs the soft start time. During soft start, EAOUT follows the amplitude of SS's slowly increasing waveform until regulation is achieved.

VDD: Chip power supply pin. VDD should be bypassed to PGND. The -1 and -3 versions require VDD to exceed 9V to start and remain above 8.5V to continue running. A shunt clamp from VDD to GND limits the supply voltage to 15V. The -2 and -4 versions do not start until the shunt clamp threshold is reached and operation continues as long as VDD is greater than 8.5V.

APPLICATION INFORMATION

UVLO and Startup

For self biased off-line applications, -2 and -4 versions (UVLO on and off thresholds of 15V and 8.5V typical) are recommended. For all other applications, -1 and -3 versions provide the lower on threshold of 9V. The IC requires a low startup current of only 160µA when VDD is under the UVLO threshold, enabling use of a large trickle charge resistor (with corresponding low power dissipation) from the input voltage. VDD has an internal clamp at 15V which can sink up to 10mA. Measures should be taken not to exceed this current. For -2 and -4 versions, this clamp must be activated as an indication of reaching the UVLO on threshold. The internal reference (REF) is brought up when the UVLO on threshold is crossed. The startup logic ensures that LINE and REF are above and SHTDWN is below their respective thresholds before outputs are asserted. LINE input is useful for monitoring actual input voltage and shutting off the IC if it falls below a programmed value. A resistive divider should be used to connect the input voltage to the LINE input. This feature can protect the power supply from excessive currents at low line voltages.

The soft start pin provides an effective means to start the IC in a controlled manner. An internal current of 20µA begins charging a capacitor connected to SS once the startup conditions listed above have been met. The voltage on SS effectively controls maximum duty cycle on OUT1 during the charging period. OUT2 is also controlled during this period (see Figure 1). Negation of any of the startup conditions causes SS to be immediately discharged. Internal circuitry ensures full discharge of SS (to 0.3V) before allowing charging to begin again, provided all the startup conditions are again met.

Oscillator

Simplified oscillator block diagram and waveforms are shown in Figure 3. OSC1 and OSC2 pins are used to program the frequency and maximum duty cycle. Capacitor CT is alternately charged through R1 and discharged through R2 between levels of 1V and 3.5V. The charging and discharging equations for CT are given by

$$V_c(\text{charge}) = \text{REF} - 4.0 \cdot e^{-t/t_1}$$

$$V_c(\text{discharge}) = 3.5 \cdot e^{-t/t_2}$$

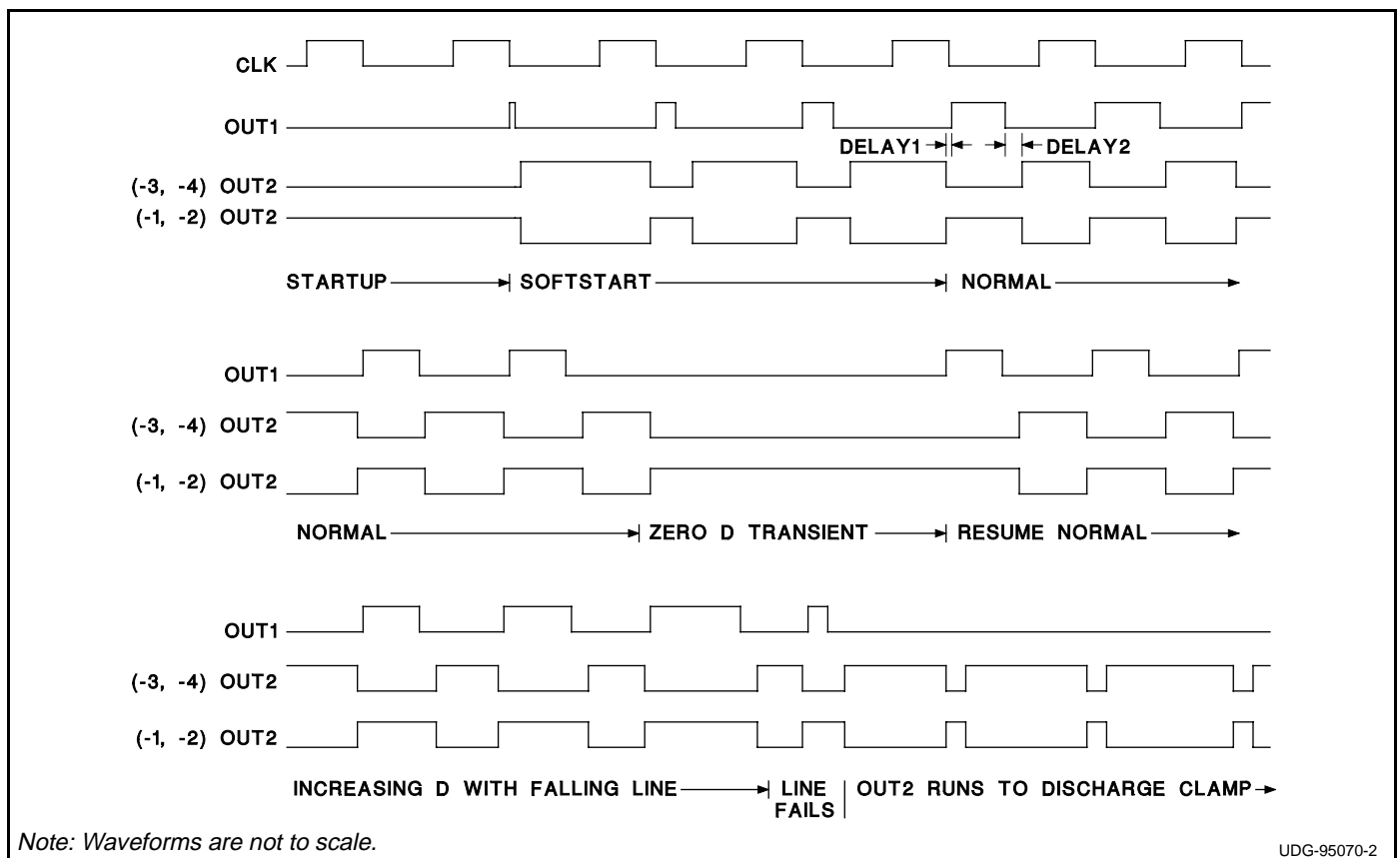

Figure 1. Output Time Relationships

APPLICATION INFORMATION (cont.)

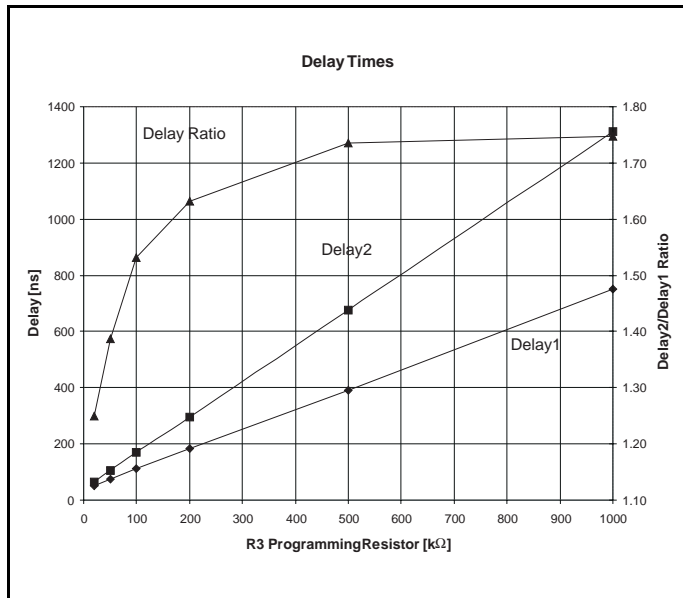

Figure 2. Delay Times

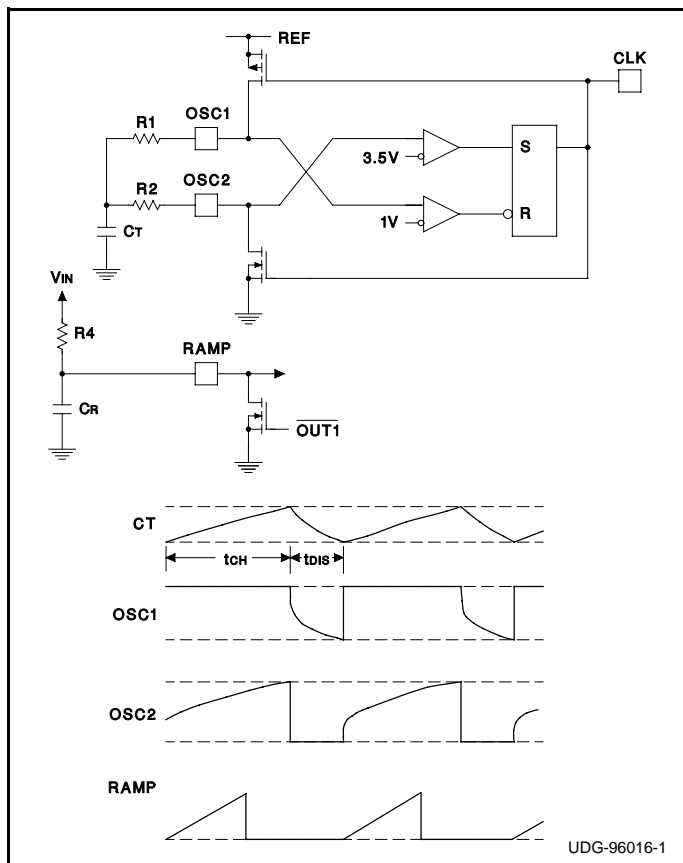

Figure 3. Oscillator and Ramp Circuits

where $\tau_1 = R1 \cdot Ct$ and $\tau_2 = R2 \cdot Ct$. The charge time and discharge time are given by

$$t_{CH} = R1 \cdot Ct \text{ and } t_{DIS} = 1.25 \cdot R2 \cdot Ct$$

The CLK output is high during the discharge period. It blanks the output to limit the maximum duty cycle of OUT1. The frequency and maximum duty cycle are given by

$$\text{Frequency} = \frac{1}{(R1 + 1.25 \cdot R2) \cdot Ct}$$

$$\text{Maximum Duty Cycle} = \frac{R1}{R1 + 1.25 \cdot R2}$$

Maximum Duty Cycle for OUT1 will be slightly less due to Delay1 which is programmed by R3.

Voltage Feedforward and Volt-Second Clamp

UCC3580 has a provision for input voltage feedforward. As shown in Figure 3, the ramp slope is made proportional to input line voltage by converting it into a charging current for CR. This provides a first order cancellation of the effects of line voltage changes on converter performance. The maximum volt-second clamp is provided to protect against transient saturation of the transformer core. It terminates the OUT1 pulse when the RAMP voltage exceeds 3.3V. If the feedforward feature is not used, the ramp can be generated by tying R4 to REF. However, the linearity of ramp suffers and in this case the maximum volt-second clamp is no longer available.

Output Configurations

The UCC3580 family of ICs is designed to provide control functions for single ended active clamp circuits. For different implementations of the active clamp approach, different drive waveforms for the two switches (main and auxiliary) are required. The -3 and -4 versions of the IC supply complementary non-overlapping waveforms (OUT1 and OUT2) with programmable delay which can be used to drive the main and auxiliary switches. Most active clamp configurations will require one of these outputs to be transformer coupled to drive a floating switch (e.g. Figure 5). The -1 and -2 versions have the phase of OUT2 inverted to give overlapping waveforms. This configuration is suitable for capacity coupled driving of a ground referenced p-channel auxiliary switch with the OUT2 drive while OUT1 is directly driving an n-channel main switch (e.g. Figure 4).

The programmable delay can be judiciously used to get zero voltage turn-on of both the main and auxiliary switches in the active clamp circuits. For the UCC3580, a single pin is used to program the delays between OUT1 and OUT2 on both sets of edges. Figure 1 shows the relationships between the outputs. Figure 2 gives the ratio between the two delays. During the transition from main to auxiliary switch, the delay is not

APPLICATION INFORMATION (cont.)

very critical for ZVS turn-on. For the first half of OUT1 off-time, the body diode of the auxiliary switch conducts and OUT2 can be turned on any time. The transition from auxiliary to main switch is more critical. Energy stored in the parasitic inductance(s) at the end of the OUT2 pulse is used to discharge the parasitic capacitance across the main switch during the delay time. The delay (Delay 1) should be optimally programmed at $1/4$ the resonant period determined by parasitic capacitance and the resonant inductor (transformer leakage and/or magnetizing inductances, depending on the topology). However, depending on other circuit parasitics, the resonant behavior can change, and in some cases, ZVS turn-on may not be obtainable. It can be shown that the optimum delay time is independent of operating conditions for a specific circuit and should be determined specifically for each circuit.

Output Behavior During Fault Modes

The UCC3580 family is designed to protect power converter components against faults such as input line

dropout and output overcurrent. These fault conditions are latched and require full soft start recycling. The IC does not provide cycle-by-cycle current limiting as duty cycle hiccups can cause instabilities and/or cross conduction in active clamp type circuits. Instead the IC has a smart output sequencing feature to protect against transients. When the error amplifier output commands low duty cycle (of OUT1) as a result of a load transient, the IC senses it and drives both switches (main and auxiliary) off. As a result, the steady state operating conditions such as clamp capacitance voltage are not abruptly changed. In all other cases, normal logic prevails where OUT2 (-3, -4) is a true complement of OUT1 with delay (dead) times between them. When LINE goes low, OUT1 goes to zero duty cycle, but OUT2 (-3, -4) keeps pulsing at full duty cycle (switching period minus Delay1 and Delay2) in order to discharge the clamp capacitance to zero and prepare for full soft start cycle.

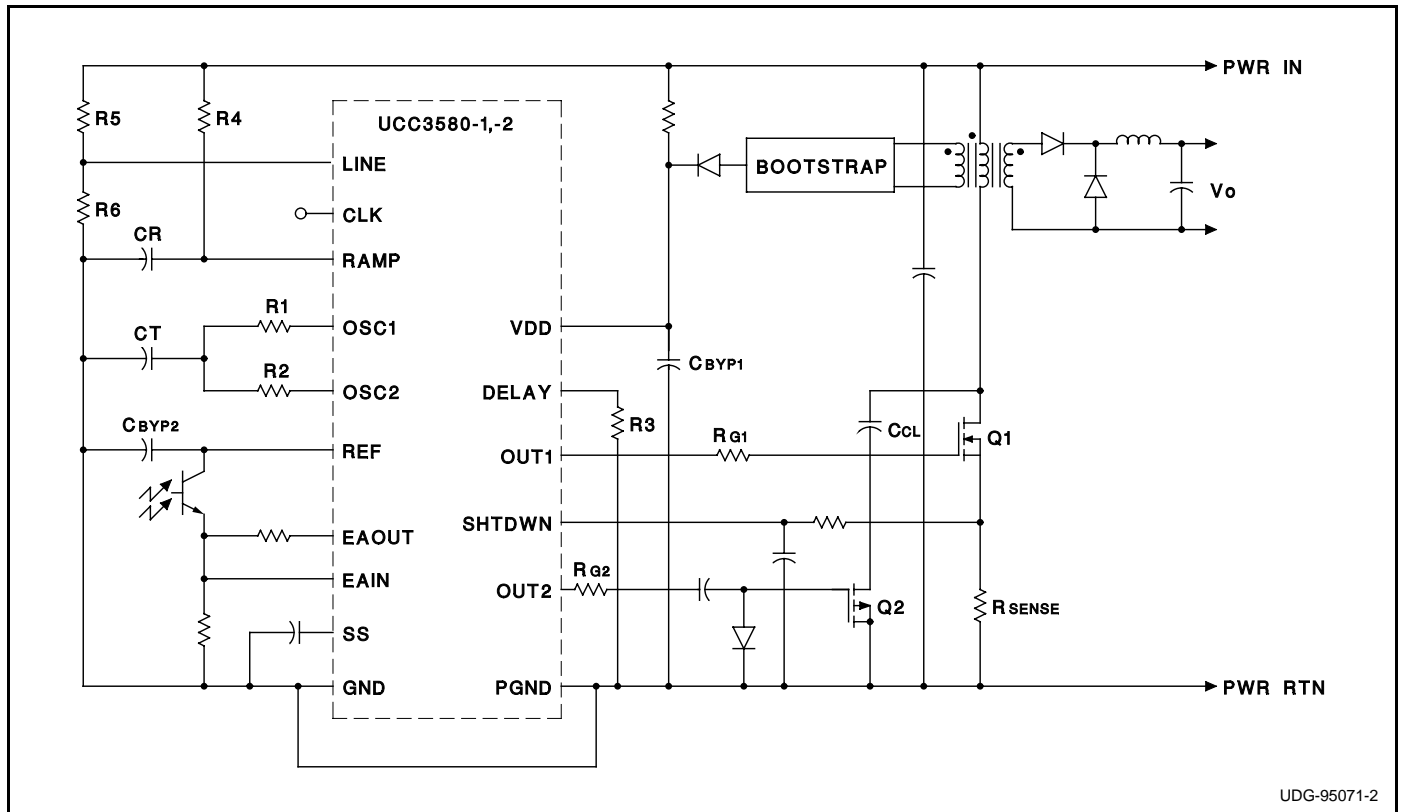
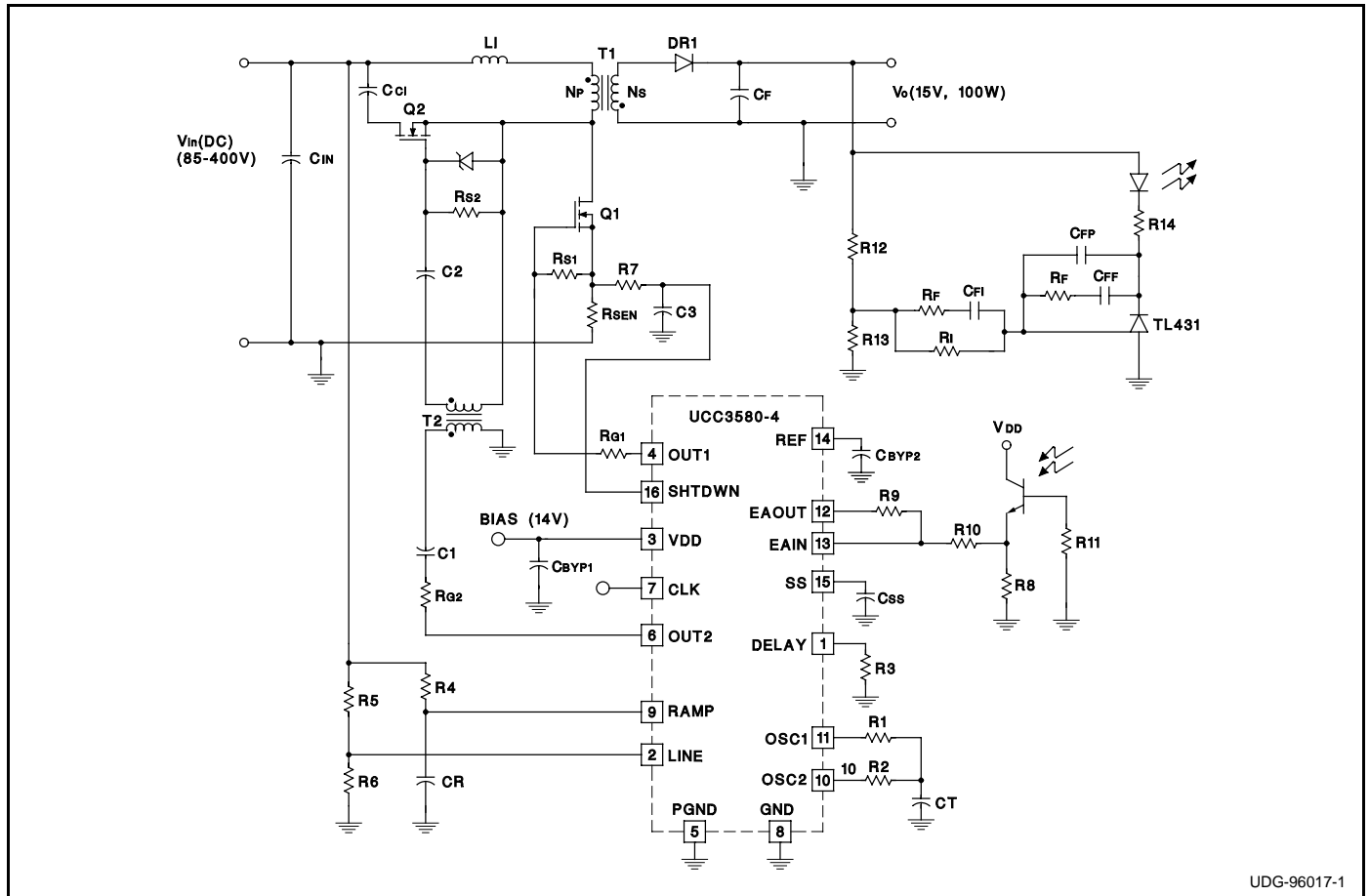

Figure 4. Active Clamp Forward Converter

APPLICATION INFORMATION (cont.)



UDG-96017-1

Figure 5. Off-line Active Clamp Flyback Converter

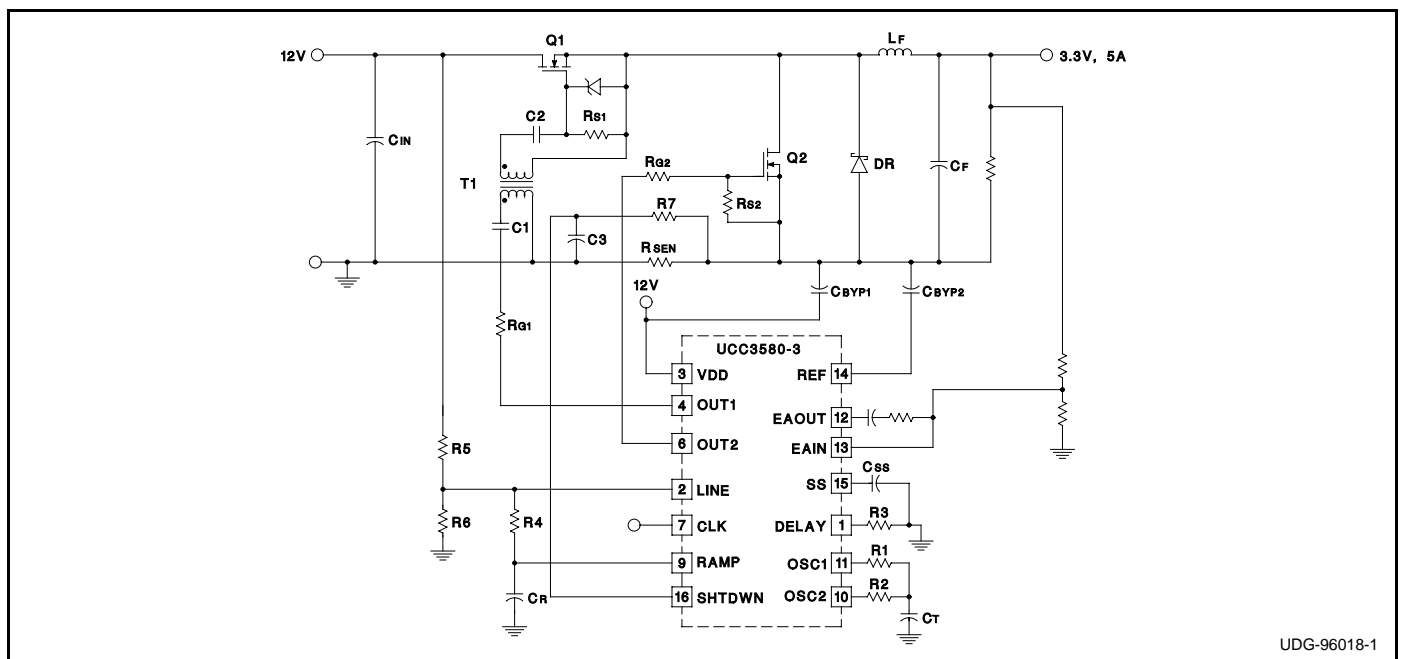

UDG-96018-1

Figure 6. UCC3580 Used in a Synchronous Rectifier Application