

Programmable Maximum Duty Cycle PWM Controller

FEATURES

- User Programmable Maximum PWM Duty Cycle
- 100µA Startup Current
- Operation to 1MHz
- Internal Full Cycle Soft Start
- Internal Leading Edge Blanking of Current Sense Signal
- 1 Amp Totem Pole Output

DESCRIPTION

The UCC3807 family of high speed, low power integrated circuits contains all of the control and drive circuitry required for off-line and DC-to-DC fixed frequency current mode switching power supplies with minimal external parts count.

These devices are similar to the UCC3800 family, but with the added feature of a user programmable maximum duty cycle. Oscillator frequency and maximum duty cycle are programmed with two resistors and a capacitor. The UCC3807 family also features internal full cycle soft start and internal leading edge blanking of the current sense input.

The UCC3807 family offers a variety of package options, temperature range options, and choice of critical voltage levels. The family has UVLO thresholds and hysteresis levels for off-line and battery powered systems. Thresholds are shown in the table below.

Part Number	Turn-on Threshold	Turn-off Threshold
UCCx807-1	7.2V	6.9V
UCCx807-2	12.5V	8.3V
UCCx807-3	4.3V	4.1V

BLOCK DIAGRAM

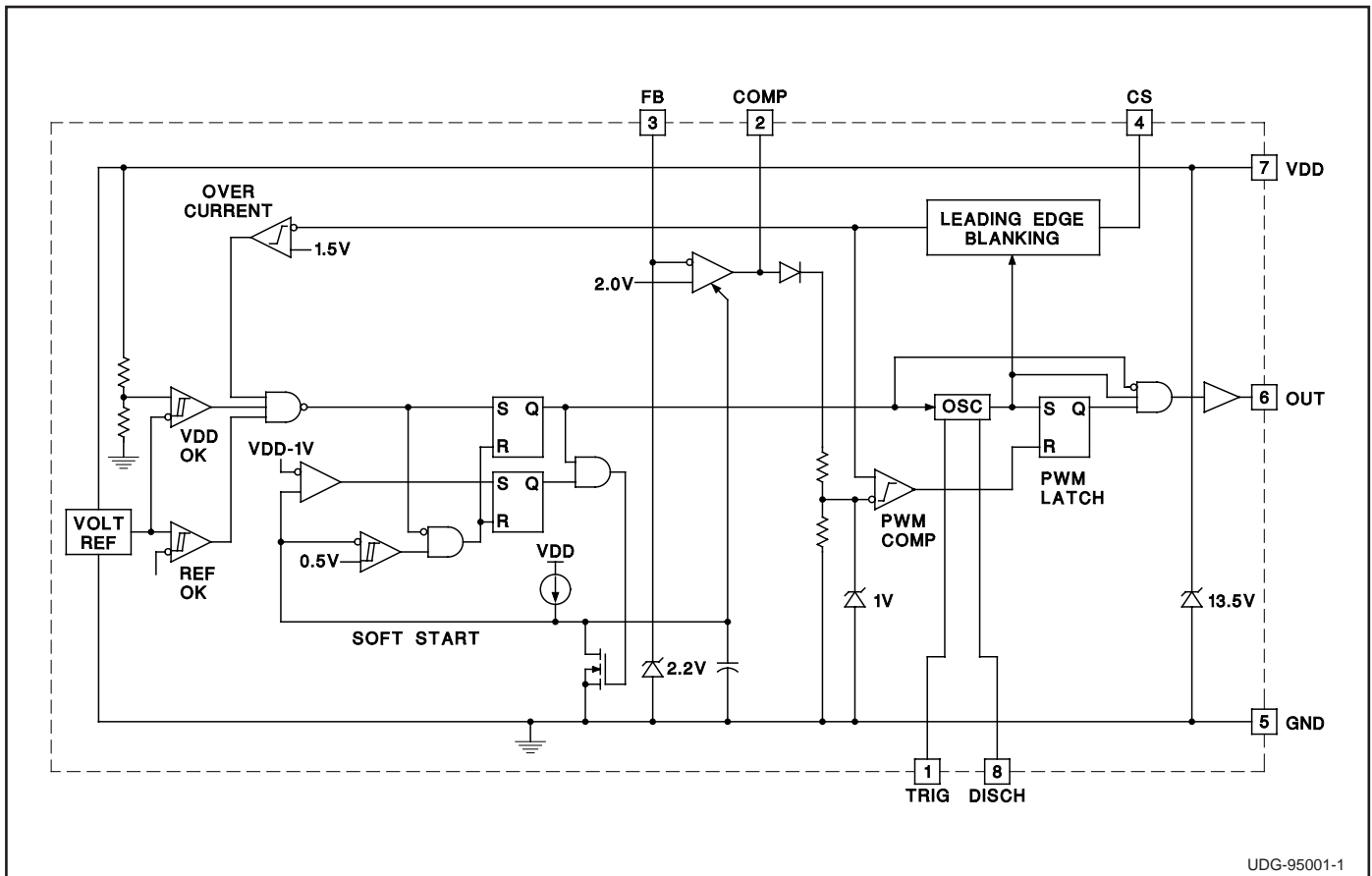

UDG-95001-1

ABSOLUTE MAXIMUM RATINGS

Supply Voltage ($I_{DD} \leq 10\text{mA}$)13.5V
 Supply Current30mA
 OUT Current $\pm 1\text{A}$
 Analog Inputs (FB, CS)-0.3V to (VDD + 0.3V)
 Power Dissipation at $T_A +25^\circ\text{C}$ (N or J packages)1W
 Power Dissipation at $T_A +25^\circ\text{C}$ (D package)0.65W
 Storage Temperature-65°C to +150°C
 Junction Temperature-65°C to +150°C
 Lead Temperature (Soldering, 10 sec.)+300°C
*All currents are positive into, negative out of the specified terminal.
 Consult Packaging Section of Databook for thermal limitations
 and considerations of packages.*

ORDERING INFORMATION

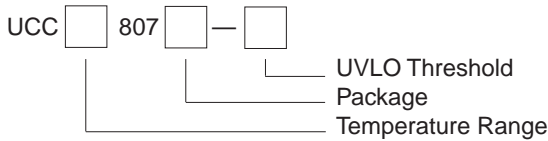

CONNECTION DIAGRAM

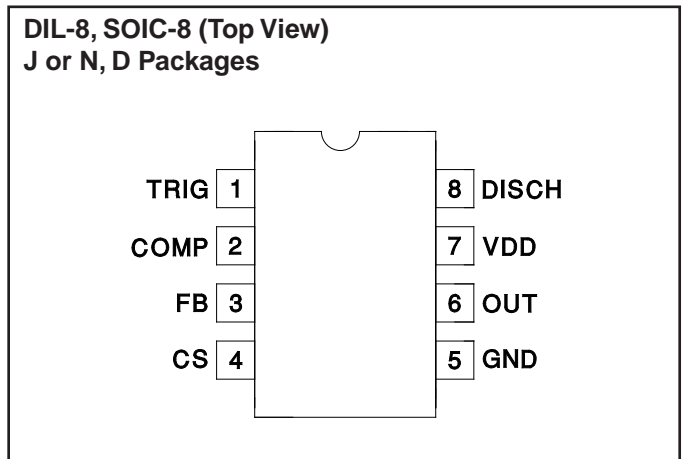

ELECTRICAL CHARACTERISTICS Unless otherwise stated these specifications apply for $T_A = -55^\circ\text{C}$ to $+125^\circ\text{C}$ for UCC1807-1/-2/-3; -40°C to $+85^\circ\text{C}$ for UCC2807-1/-2/-3; and 0°C to $+70^\circ\text{C}$ for UCC3807-1/-2/-3; VDD = 10V (Note 6), $R_A = 12\text{k}\Omega$, $R_B = 4.7\text{k}\Omega$, $C_T = 330\text{pF}$, 1.0 μF capacitor from VDD to GND, $T_A = T_J$.

PARAMETER	TEST CONDITION	MIN	TYP	MAX	UNITS
Oscillator Section					
Frequency		175	202	228	kHz
Temperature Stability	(Note 5)		2.5		%
Amplitude	(Note 1)		1/3VDD		V
Error Amplifier Section					
Input Voltage	COMP = 2.0V	1.95	2.00	2.05	V
Input Bias Current		-1		1	μA
Open Loop Voltage Gain		60	80		dB
COMP Sink Current	FB = 2.2V, COMP = 1.0V	0.3	2.5		mA
COMP Source Current	FB = 1.3V, COMP = 4.0V	-0.2	-0.5		mA
PWM Section					
Maximum Duty Cycle		75	78	81	%
Minimum Duty Cycle	COMP = 0V			0	%
Current Sense Section					
Gain	(Note 2)	1.1	1.65	1.8	V/V
Maximum Input Signal	COMP = 5.0V (Note 3)	0.9	1.0	1.1	V
Input Bias Current		-200		200	nA
CS Blank Time		50	100	150	ns
Overcurrent Threshold		1.4	1.5	1.6	V
COMP to CS Offset	CS = 0V	0.55	1.1	1.65	V
Output Section					
OUT Low Level	$I = 100\text{mA}$		0.4	1	V
OUT High Level	$I = -100\text{mA}$, VDD - OUT		0.4	1	V
Rise/Fall Time	CL = 1nF (Note 5)		20	100	ns

ELECTRICAL CHARACTERISTICS (cont.) Unless otherwise stated these specifications apply for T_A = -55°C to +125°C for UCC1807-1/-2/-3; -40°C to +85°C for UCC2807-1/-2/-3; and 0°C to +70°C for UCC3807-1/-2/-3; V_{DD} = 10V (Note 6), R_A = 12kΩ, R_B = 4.7kΩ, C_T = 330pF, 1.0μF capacitor from V_{DD} to GND, T_A = T_J.

PARAMETER	TEST CONDITION	MIN	TYP	MAX	UNITS
Undervoltage Lockout Section					
Start Threshold	UCCx807-1 (Note 4)	6.6	7.2	7.8	V
	UCCx807-2	11.5	12.5	13.5	V
	UCCx807-3	4.1	4.3	4.5	V
Minimum Operating Voltage After Start	UCCx807-1 (Note 4)	6.3	6.9	7.5	V
	UCCx807-2	7.6	8.3	9.0	V
	UCCx807-3	3.9	4.1	4.3	V
Hysteresis	UCCx807-1	0.1	0.3	0.5	V
	UCCx807-2	3.5	4.2	5.1	V
	UCCx807-3	0.1	0.2	0.3	V
Soft Start Section					
COMP Rise Time	FB = 1.8V, From 0.5V to 4.0V		4		ms
Overall Section					
Startup Current	V _{DD} < Start Threshold (UCCx807-1,-3)		0.1	0.2	mA
	V _{DD} < Start Threshold (UCCx807-2)		0.15	0.25	mA
Operating Supply Current	FB = 0V, CS = 0V, No Load (Note 7)		1.3	2.1	mA
V _{DD} Zener Shunt Voltage	I _{DD} = 10mA	12.0	13.5	15.0	V
Shunt to Start Difference		0.5	1.0		V

Note 1: Measured at TRIG; signal minimum = 1/3 V_{DD}, maximum = 2/3 V_{DD}.

Note 2: Gain is defined by: $A = \frac{\Delta V_{COMP}}{\Delta V_{CS}}$, $0 \leq V_{CS} \leq 0.8V$

Note 3: Parameter measured at trip point of latch with FB at 0V.

Note 4: Start Threshold and Zener Shunt thresholds track one another.

Note 5: Guaranteed by design. Not 100% tested in production.

Note 6: Adjust V_{DD} above the start threshold before setting at 10V for UCC3807-2.

Note 7: Does not include current in external timing RC network.

PIN DESCRIPTIONS

COMP: COMP is the output of the error amplifier and the input of the PWM comparator. The error amplifier in the UCC3807 is a low output impedance, 2MHz operational amplifier. COMP can both source and sink current. The error amplifier is internally current limited, which allows zero duty cycle by externally forcing COMP to GND.

The UCC3807 family features built-in full cycle soft start. Soft start is implemented as a clamp on the maximum COMP voltage.

CS: Current sense input. There are two current sense comparators on the chip, the PWM comparator and an overcurrent comparator.

The UCC3807 also contains a leading edge blanking circuit, which disconnects the external CS signal from the current sense comparator during the 100ns interval immediately following the rising edge of the signal at the OUT pin. In most applications, no analog filtering is required on CS. Compared to an external RC filtering technique, leading edge blanking provides a smaller effective CS to OUT propagation delay. Note, however, that the minimum non-zero on-time of the OUT signal is

directly affected by the leading edge blanking and the CS to OUT propagation delay.

The overcurrent comparator is only intended for fault sensing. Exceeding the overcurrent threshold causes a soft start cycle.

FB: The inverting input to the error amplifier. For best stability, keep connections to FB as short as possible and stray capacitance as small as possible.

GND: Reference ground and power ground for all functions of the part.

OUT: The output of a high current power driver capable of driving the gate of a power MOSFET with peak currents exceeding 1A. OUT is actively held low when V_{DD} is below the UVLO threshold.

The high current power driver consists of MOSFET output devices in a totem pole configuration. This allows the output to switch from V_{DD} to GND. The output stage also provides a very low impedance which minimizes overshoot and undershoot. In most cases, external Schottky clamp diodes are not required.

PIN DESCRIPTIONS (cont.)

TRIG/DISCH: Oscillator control pins. TRIG is the oscillator timing input, which has an RC-type charge/discharge signal controlling the chip's internal oscillator. DISCH is the pin which provides the low impedance discharge path for the external RC network during normal operation. Oscillator frequency and maximum duty cycle are computed as follows:

$$\text{frequency} \approx \frac{1.4}{(R_A + 2R_B)C_T}$$

$$\text{duty cycle} \approx \frac{R_A + R_B}{R_A + 2R_B}$$

as shown in Figure 1.

For best performance, keep the lead from C_T to GND as short as possible. A separate ground connection for C_T is desirable. The minimum value of R_A is 10kΩ, the minimum value of R_B is 2.2kΩ, and the minimum value of C_T is 47pF.

VDD: The power input connection for this device. Total VDD current is the sum of quiescent current and the average OUT current. Knowing the operating frequency and the MOSFET gate charge (Q_g), average OUT current can be calculated from

$$I_{OUT} = Q_g \cdot F, \text{ where } F \text{ is frequency.}$$

To prevent noise problems, bypass VDD to GND with a ceramic capacitor as close to the chip as possible in parallel with an electrolytic capacitor.

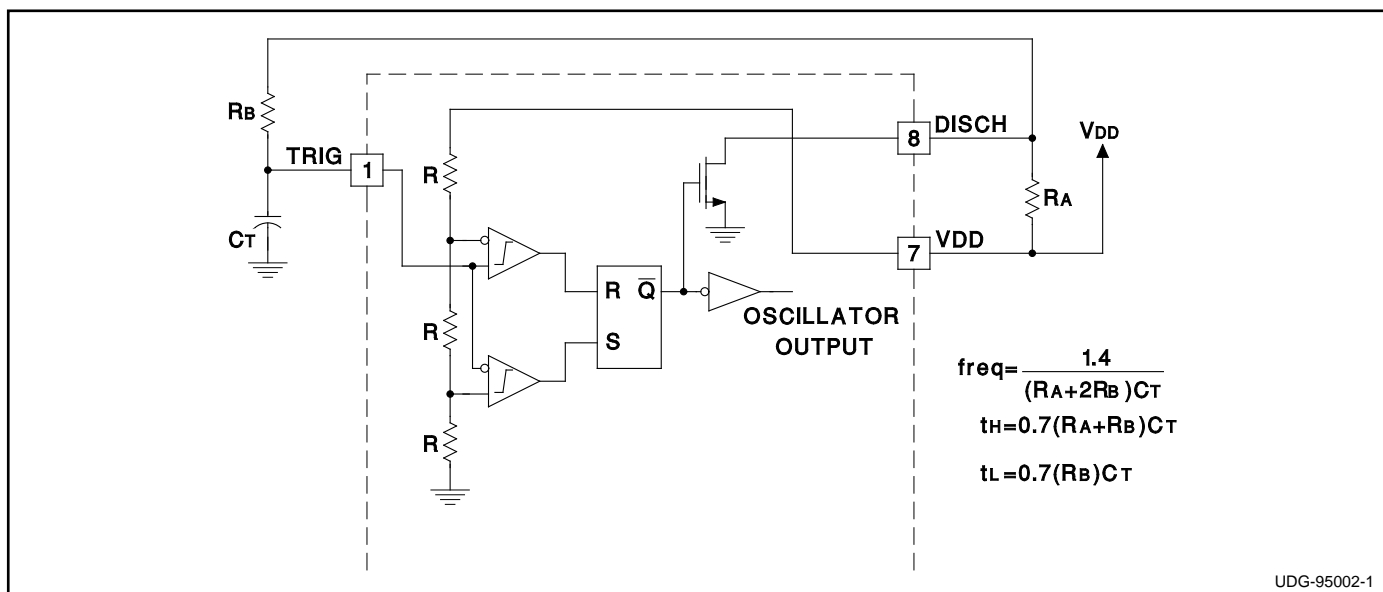

Figure 1. Oscillator Block Diagram

APPLICATIONS INFORMATION

The circuit shown in Figure 2 illustrates the use of the UCC3807 in a typical off-line application. The 100W, 200kHz, universal input forward converter produces a regulated 12VDC at 8 Amps. The programmable maximum duty cycle of the UCC3807 allows operation down to 80VRMS and up to 265VRMS with a simple RCD clamp to limit the MOSFET voltage and provide core reset. In this application the maximum duty cycle is set to about 65%. Another feature of the design is the use of a flyback winding on the output filter choke for both bootstrapping and voltage regulation. This method of loop closure eliminates the optocoupler and secondary side regulator, common to most off-line designs, while providing good line and load regulation.

T1:	
Core:	Magnetics Inc. #P-42625-UG (ungapped)
Primary:	28 turns of 2x #26AWG
Secondary:	6 turns of 50x0.2mm Litz wire
L1:	
Core:	Magnetics Inc. #P-42625-SG-37 (0.020" gap)
Main Winding:	13 turns of 2x #18AWG
Second Winding:	11 turns of #26AWG
Magnetics Inc.	
900 E. Butler Road	
P.O. Box 391	
Butler, PA 16003	
Tel: (412) 282-8282	
Fax: (412) 282-6955	

APPLICATIONS INFORMATION (cont.)

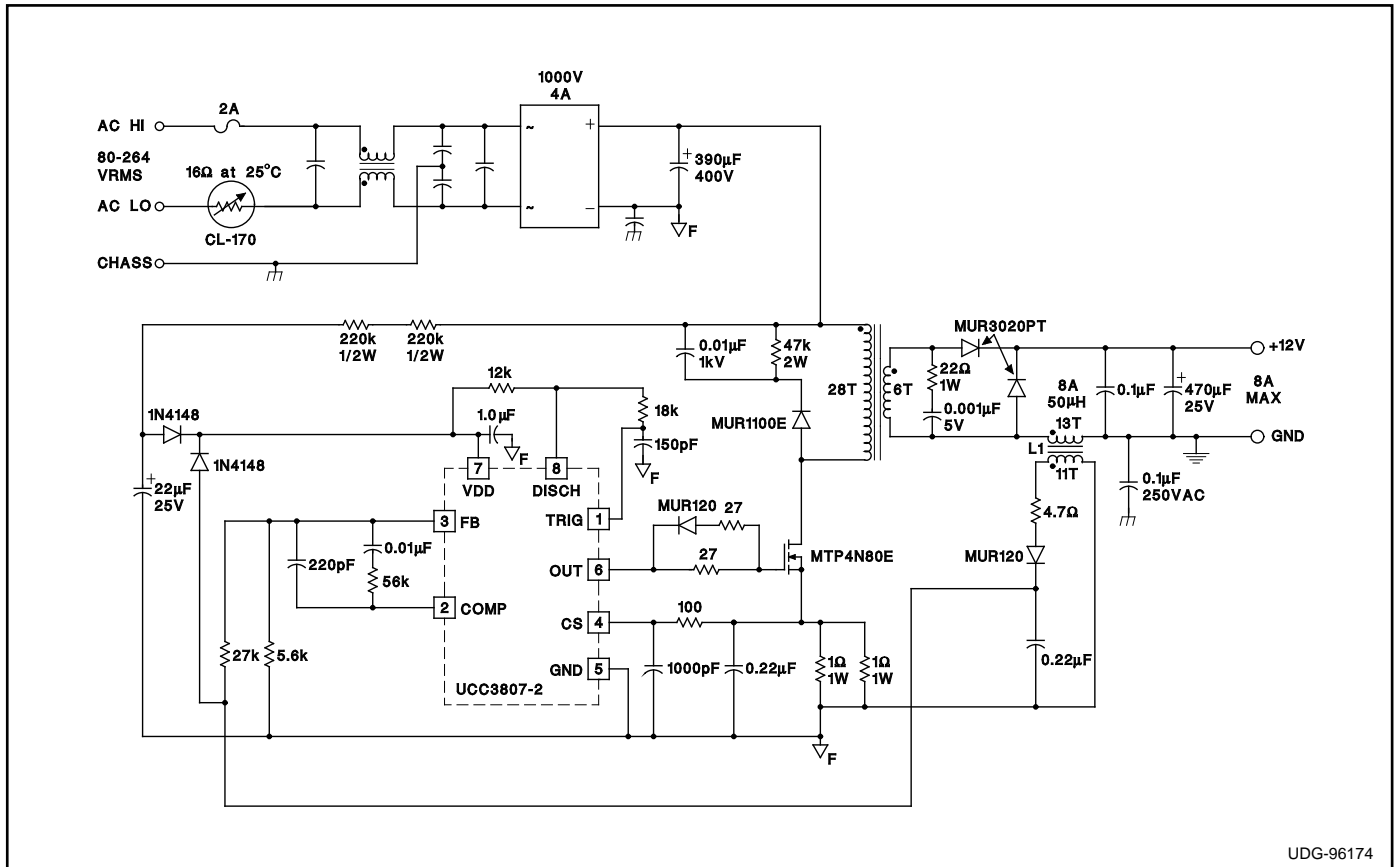

Figure 2. Typical Off-line Application Using UCC3807-2

UDG-96174