

**A. Ferrero, J. Murphy, et. al.. "Voltage Measurement."**

**Copyright 2000 CRC Press LLC. <<http://www.engnetbase.com>>.**

# Voltage Measurement

---

Alessandro Ferrero

*Politecnico di Milano*

Jerry Murphy

*Hewlett Packard Company*

Cipriano Bartoletti

*University of Rome "La Sapienza"*

Luca Podestà

*University of Rome "La Sapienza"*

Giancarlo Sacerdoti

*University of Rome "La Sapienza"*

- 37.1 Meter Voltage Measurement  
Electromechanical Voltmeters • Electronic Voltmeters • Analog Voltmeters
- 37.2 Oscilloscope Voltage Measurement  
The Oscilloscope Block Diagram • The Oscilloscope As a Voltage Measurement Instrument • Analog or Digital • Voltage Measurements • Understanding the Specifications • Triggering • Conclusion • Selecting the Oscilloscope
- 37.3 Inductive Capacitive Voltage Measurement  
Capacitive Sensors • Inductive Sensors • Defining Terms

## 37.1 Meter Voltage Measurement

---

*Alessandro Ferrero*

Instruments for the measurement of electric voltage are called *voltmeters*. Correct insertion of a voltmeter requires the connection of its terminals to the points of an electric circuit across which the voltage has to be measured, as shown in [Figure 37.1](#). To a first approximation, the electric equivalent circuit of a voltmeter can be represented by a resistive impedance  $Z_v$  (or a pure resistance  $R_v$  for dc voltmeters). This means that any voltmeter, once connected to an electric circuit, draws a current  $I_v$  given by:

$$I_v = \frac{U}{Z_v} \quad (37.1)$$

where  $U$  is the measured voltage. The higher the value of the internal impedance, the higher the quality of the voltmeter, since it does not significantly modify the status of the electric circuit under test.

Different operating principles are used to measure an electric voltage. The mechanical interaction between currents, between a current and a magnetic field, or between electrified conductors was widely adopted in the past to generate a mechanical torque proportional to the voltage or the squared voltage to be measured. This torque, balanced by a restraining torque, usually generated by a spring, causes the instrument pointer, which can be a mechanical or a virtual optical pointer, to be displaced by an angle proportional to the driving torque, and hence to the voltage or the squared voltage to be measured. The value of the input voltage is therefore given by the reading of the pointer displacement on a graduated scale. The thermal effects of a current flowing in a conductor are also used for measuring electric voltages, although they have not been adopted as widely as the previous ones. More recently, the widespread diffusion of semiconductor devices led to the development of a completely different class of voltmeters: *electronic* voltmeters. They basically attain the required measurement by processing the input signal by means of electronic semiconductor devices. According to the method, analog or digital, the input signal is processed, the electronic voltmeters can be divided into *analog* electronic voltmeters and *digital*

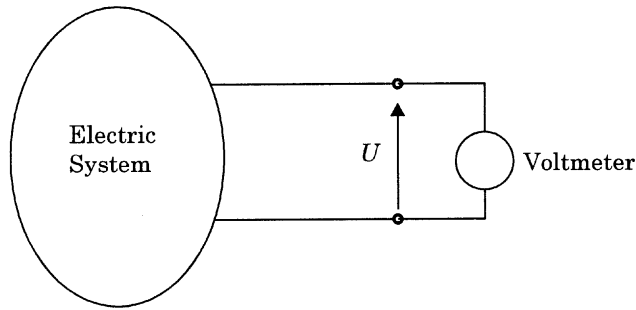

**FIGURE 37.1** Voltmeter insertion.

**TABLE 37.1** Classification of Voltage Meters

Class	Operating principle	Subclass	Application field
Electromagnetic	Interaction between currents and magnetic fields	Moving magnet	Dc voltage
		Moving coil	Dc voltage
		Moving iron	Dc and ac voltage
Electrodynamic	Interactions between currents	—	Dc and ac voltage
Electrostatic	Electrostatic interactions	—	Dc and ac voltage
Thermal	Current's thermal effects	Direct action	Dc and ac voltage
		Indirect action	Dc and ac voltage
Induction	Magnetic induction	—	Ac voltage
Electronic	Signal processing	Analog	Dc and ac voltage
		Digital	Dc and ac voltage

electronic voltmeters. Table 37.1 shows a rough classification of the most commonly employed voltmeters, according to their operating principle and their typical application field.

This chapter section briefly describes the most commonly employed voltmeters, both electromechanical and electronic.

## Electromechanical Voltmeters

Electromechanical voltmeters measure the applied voltage by transducing it into a mechanical torque. This can be accomplished in different ways, basically because of the interactions between currents (*electrodynamic voltmeters*), between a current and a magnetic field (*electromagnetic voltmeters*), between electrified conductors (*electrostatic voltmeters*, or *electrometers*), and between currents induced in a conducting vane (*induction voltmeters*). According to the different kinds of interactions, different families of instruments can be described, with different application fields. Moving-coil electromagnetic voltmeters are restricted to the measurement of dc voltages; moving-iron electromagnetic, electrodynamic, and electrostatic voltmeters can be used to measure both dc and ac voltages; while induction voltmeters are restricted to ac voltages.

The most commonly employed electromechanical voltmeters are the electromagnetic and electrodynamic ones. Electrostatic voltmeters have been widely employed in the past (and are still employed) for the measurement of high voltages, both dc and ac, up to a frequency on the order of several megahertz. Induction voltmeters have never been widely employed, and their present use is restricted to ac voltages.

Therefore, only the electromagnetic, electrodynamic, and electrostatic voltmeters will be described in the following.

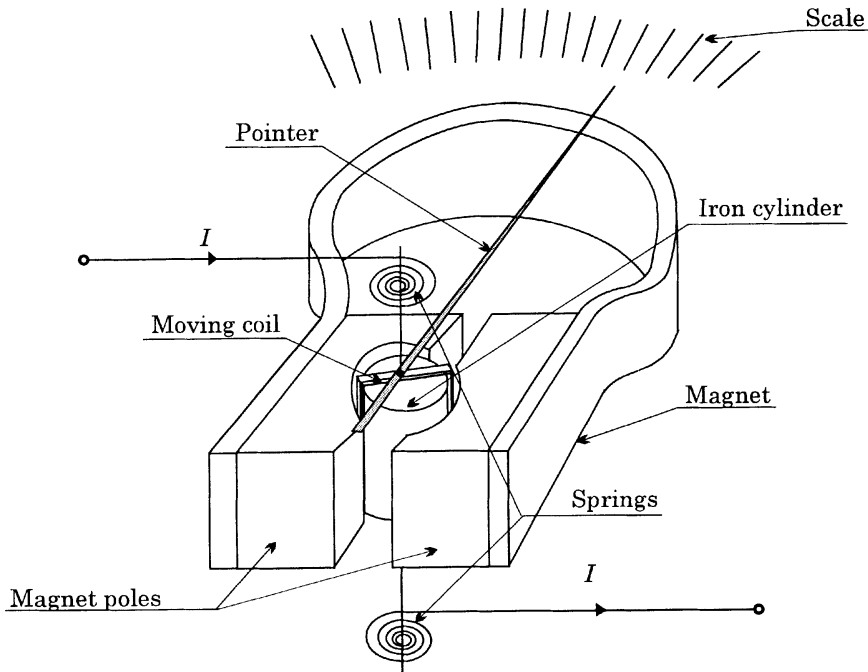

FIGURE 37.2 Dc moving-coil meter.

### Electromagnetic Voltmeters

Dc Moving-Coil Voltmeters.

The structure of a dc moving-coil meter is shown in Figure 37.2. A small rectangular pivoted coil is wrapped around an iron cylinder and placed between the poles of a permanent magnet. Because of the shape of the poles of the permanent magnet, the induction magnetic field  $B$  in the air gap is radial and constant.

Suppose that a dc current  $I$  is flowing in the coil, the coil has  $N$  turns, and that the length of the sides that cut the magnetic flux (active sides) is  $l$ ; the current interacts with the magnetic field  $B$  and a force  $F$  is exerted on the conductors of the active sides. The value of this force is given by:

$$F = NBII \quad (37.2)$$

Its direction is given by the right-hand rule. Since the two forces applied to the two active sides of the coil are directed in opposite directions, a torque arises in the coil, given by:

$$T_i = Fd = NBldI \quad (37.3)$$

where  $d$  is the coil width. Since  $N$ ,  $B$ ,  $l$ ,  $d$  are constant, Equation 37.3 leads to:

$$T_i = k_i I \quad (37.4)$$

showing that the mechanical torque exerted on the coil is directly proportional to the current flowing in the coil itself.

Because of  $T_r$ , the coil rotates around its axis. Two little control springs, with  $k_r$  constant, provide a restraining torque  $T_r$ . The two torques balance when the coil is rotated by an angle  $\delta$  so that:

$$k_i I = k_r \delta \quad (37.5)$$

which leads to:

$$\delta = \frac{k_i}{k_r} I \quad (37.6)$$

Equation 37.6 shows that the rotation angle of the coil is directly proportional to the dc current flowing in the coil. If a pointer with length  $h$  is keyed on the coil axes, a displacement  $\lambda = h\delta$  can be read on the instrument scale. Therefore, the pointer displacement is proportional to the current flowing in the coil, according to the following relationship:

$$\lambda = h \frac{k_i}{k_r} I \quad (37.7)$$

This instrument is hence intrinsically a current meter. A voltmeter can be obtained by connecting an additional resistor in series with the coil. If the coil resistance is  $R_c$ , and the resistance of the additional resistor is  $R_a$ , the current flowing in the coil when the voltage  $U$  is applied is given by:

$$I = \frac{U}{R_a + R_c} \quad (37.8)$$

and therefore the pointer displacement is given by:

$$\lambda = h\delta = h \frac{k_i}{k_r} I = h \frac{k_i}{k_r (R_a + R_c)} U \quad (37.9)$$

and is proportional to the applied voltage. Because of this proportionality, moving-coil dc meters show a proportional-law scale, where the applied voltage causes a proportional angular deflection of the pointer.

Because of the operating principle expressed by Equation 37.3, these voltmeters can measure only dc voltages. Due to the inertia of the mechanical part, ac components typically do not cause any coil rotation, and hence these meters can be also employed to measure the dc component of a variable voltage. They have been widely employed in the past for the measurement of dc voltages up to some thousands volts with a relative measurement uncertainty as low as 0.1% of the full-scale value. At present, they are being replaced by electronic voltmeters that feature the same or better accuracy at a lower cost.

#### Dc Galvanometer.

*General characteristics.* A galvanometer is used to measure low currents and low voltages. Because of the high sensitivity that this kind of measurement requires, galvanometers are widely employed as null indicators in all dc balance measurement methods (like the bridge and potentiometer methods) [1, 2].

A dc galvanometer is, basically, a dc moving coil meter, and the relationship between the index displacement and the current flowing in the moving coil is given by Equation 37.7. The instrument constant:

$$k_a = h \frac{k_i}{k_r} \quad (37.10)$$

is usually called the galvanometer *current constant* and is expressed in  $\text{mm } \mu\text{A}^{-1}$ . The galvanometer *current sensitivity* is defined as  $1/k_a$  and is expressed in  $\mu\text{A mm}^{-1}$ .

According to their particular application field, galvanometers must be chosen with particular care. If  $k_a$  is taken into account, note that once the full-scale current and the corresponding maximum pointer displacement are given, the value of the ratio  $hk_i/k_r$  is also known. However, the single values of  $h$ ,  $k_i$ , and  $k_r$  can assume any value and are usually set in order to reduce the friction effects. In fact, if the restraining friction torque  $T_f$  is taken into account in the balance equation, Equation 37.5 becomes:

$$k_i I = k_r \frac{\lambda}{h} \pm T_f \quad (37.11)$$

where the  $\pm$  sign shows that the friction torque does not have its own sign, but always opposes the rotation.

The effects of  $T_f$  can be neglected if the driving torque  $hk_i I$  and the restraining torque  $k_r \lambda$  are sufficiently greater than  $T_f$ . Moreover, since the galvanometer is employed as a null indicator, a high sensitivity is needed; hence,  $k_a$  must be as high as possible. According to Equations 37.10 and 37.11, this requires high values of  $hk_i$  and low values of  $k_r$ . A high value of  $h$  means a long pointer; a high value of  $k_i$  means a high driving torque, while a low value of  $k_r$  means that the inertia of the whole moving system must be low.

The pointer length can be increased without increasing the moving system inertia by employing virtual optical pointers: a little, light concave mirror is fixed on the moving coil axis and is lit by an external lamp. The reflected light hits a translucent, graduated ruler, so that the mirror rotation can be observed (Figure 37.3). In this way, a virtual pointer is obtained, whose length equals the distance between the mirror and the graduated ruler.

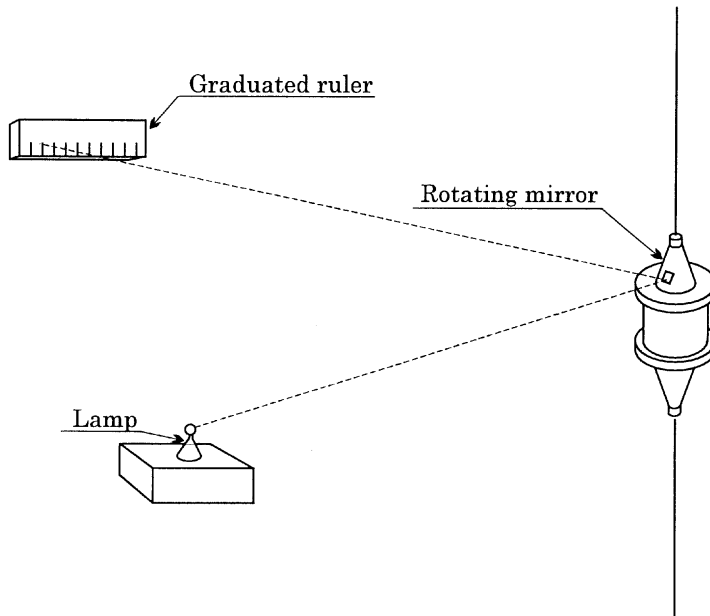

**FIGURE 37.3** Virtual optical pointer structure in a dc galvanometer.

The reduction of the moving system inertia is obtained by reducing the weight and dimension of the moving coil, and reducing the spring constant. This is usually done by suspending the moving coil with a thin fiber of conducting material (usually bronze). Thus, the friction torque is practically removed, and the restraining spring action is given by the fiber torsion.

According to Equations 37.3 and 37.4, the driving torque can be increased by increasing the coil flux linkage. Three parameters can be modified to attain this increase: the induction field  $B$ , the coil section  $ld$ , and the number of turns  $N$  of the coil winding.

The induction field  $B$  can be increased by employing high-quality permanent magnets, with high coercive force, and minimizing the air gap between the magnet's poles. This minimization prevents the use of moving coils with a large section. Moreover, large coil sections lead to heavier coils with greater inertia, which opposes the previous requirement of reduced inertia. For this reason, the coil section is usually rectangular (although a square section maximizes the flux linkage) and with  $l > d$ .

If the galvanometer is used to measure a low voltage  $U$ , the *voltage sensitivity*, expressed in  $\mu\text{V mm}^{-1}$  is the inverse of:

$$k_v = \frac{\lambda}{U} \quad (37.12)$$

where  $k_v$  is called the galvanometer's *voltage constant* and is expressed in  $\text{mm } \mu\text{V}^{-1}$ .

*Mechanical characteristics.* Due to the low inertia and low friction, the galvanometer moving system behaves as an oscillating mechanical system. The oscillations around the balance position are damped by the electromagnetic forces that the oscillations of the coil in the magnetic field exert on the coil active sides. It can be proved [1] that the oscillation damping is a function of the coil circuit resistance: that is, the coil resistance  $r$  plus the equivalent resistance of the external circuit connected to the galvanometer. In particular, the damping effect is nil if the coil circuit is open, and maximum if the coil is short-circuited.

In practical situations, a resistor is connected in series with the moving coil, whose resistance is selected in such a way to realize a critical damping of the coil movement. When this situation is obtained, the galvanometer is said to be *critically damped* and reaches its balance position in the shortest time, without oscillations around this position.

*Actual trends.* Moving-coil dc galvanometers have been widely employed in the past when they represented the most important instrument for high-sensitivity measurements. In more recent years, due to the development of the electronic devices, and particularly high-gain, low-noise amplifiers, the moving-coil galvanometers are being replaced by electronic galvanometers, which feature the same, or even better, performance than the electromagnetic ones.

## Electrodynamic Voltmeters

Ac Moving-coil Voltmeters.

The structure of an ac moving-coil meter is shown in Figure 37.4. It basically consists of a pivoted moving coil, two stationary field coils, control springs, a pointer, and a calibrated scale. The stationary coils are series connected and, when a current  $i_f$  is applied, a magnetic field  $B_f$  is generated along the axis of the stationary coils, as shown in Figure 37.5. A magnetic flux is therefore generated, whose instantaneous values are given by:

$$\varphi_f(t) = k' m_f i_f(t) \quad (37.13)$$

where  $m_f$  is the number of turns of the stationary coil and  $k'$  is a proportionality factor. When a current  $i_m$  is applied to the moving coil, a torque arises, whose instantaneous values are proportional to the product of  $\varphi_f$  and  $i_m$  instantaneous values:

$$T_i(t) = k'' \varphi_f(t) i_m(t) = k i_f(t) i_m(t) \quad (37.14)$$

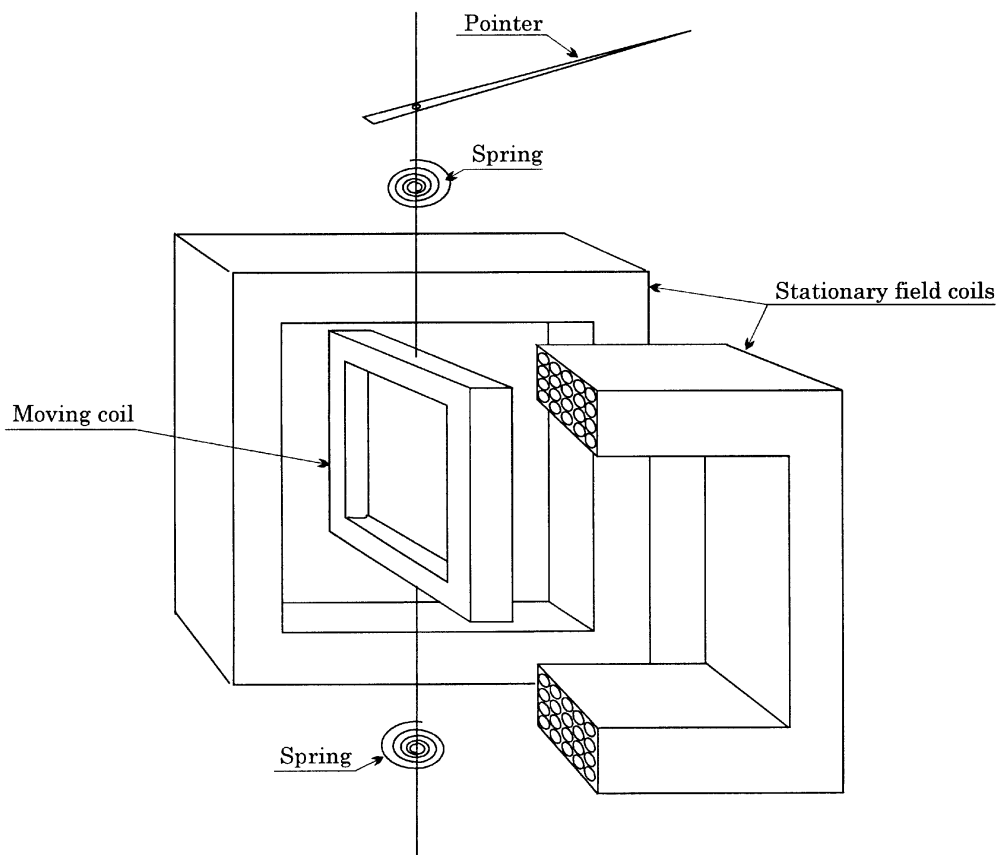

**FIGURE 37.4** Ac moving-coil meter.

The driving torque is therefore proportional to the instantaneous product of the currents flowing in the two coils. Due to this driving torque, the moving element is displaced by an angle ( $\delta t$ ), until the spring restraining torque  $T_s(t) = k_s \delta(t)$  balances the driving torque. The moving element rotation is thus given by:

$$\delta(t) = \frac{k}{k_s} i_f(t) i_m(t) \quad (37.15)$$

and, if the pointer length is  $h$ , the following pointer displacement can be read on the scale:

$$\lambda(t) = h \frac{k}{k_s} i_f(t) i_m(t) \quad (37.16)$$

The proportionality factor  $k$  is generally not constant, since it depends on the mutual inductance between the two coils, and thus on their number of turns, shape and relative position. However, if the two coils are carefully designed and placed, the magnetic field can be assumed to be constant and radial in the rotation area of the moving coil. Under this condition,  $k$  is virtually constant.

Because the bandwidth of the moving element is limited to a few hertz, due to its inertia, the balance position is proportional to the average value of the driving torque when the signal bandwidth exceeds



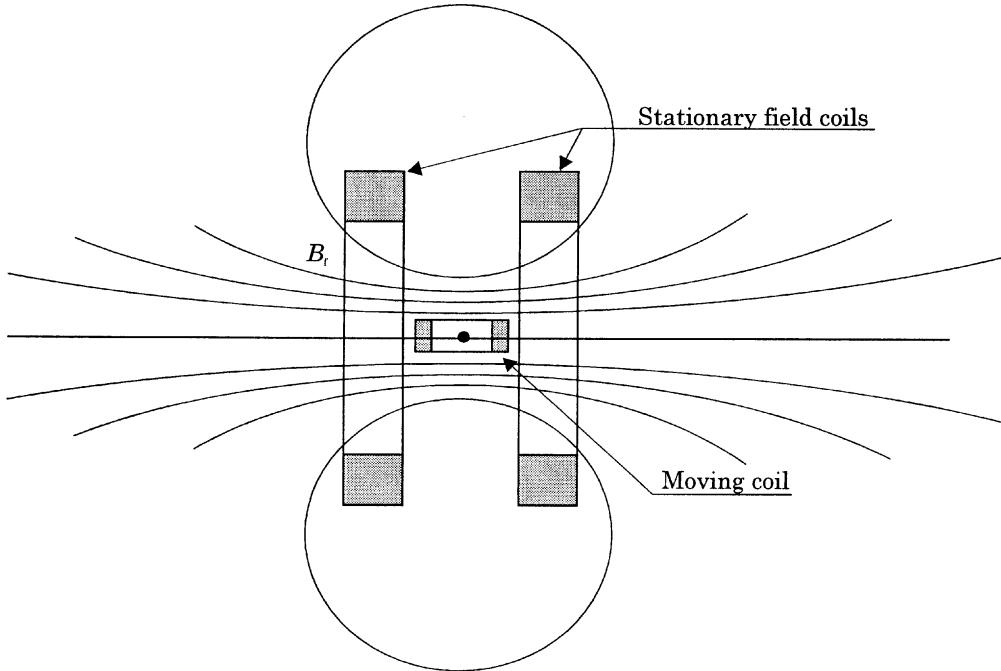

**FIGURE 37.5** Magnetic field generated by the field coils in an ac moving-coil meter.

this limit. If  $i_f$  and  $i_m$  currents are sinusoidal, with  $I_f$  and  $I_m$  rms values, respectively, and with a relative phase displacement  $\beta$ , the driving torque average value is given by:

$$\bar{T}_i = k I_f I_m \cos \beta \quad (37.17)$$

and thus, the pointer displacement in Equation 37.16 becomes:

$$\lambda = h \frac{k}{k_s} I_f I_m \cos \beta \quad (37.18)$$

In order to realize a voltmeter, the stationary and moving coils are series connected, and a resistor, with resistance  $R$ , is also connected in series to the coils. If  $R$  is far greater than the resistance of the two coils, and if it is also far greater than the coil inductance, in the frequency operating range of the voltmeter, the rms value of the coils' currents is given by:

$$I_f = I_m = \frac{U}{R} \quad (37.19)$$

$U$  being the applied voltage rms value. From Equation 37.18, the pointer displacement is therefore given by:

$$\lambda = h \frac{k}{k_s} \frac{U^2}{R^2} = k_v U^2 \quad (37.20)$$

Because of Equation 37.20, the voltmeter features a square-law scale, with  $k_v$  constant, provided that the coils are carefully designed, and that the coils' inductance can be neglected with respect to the resistance

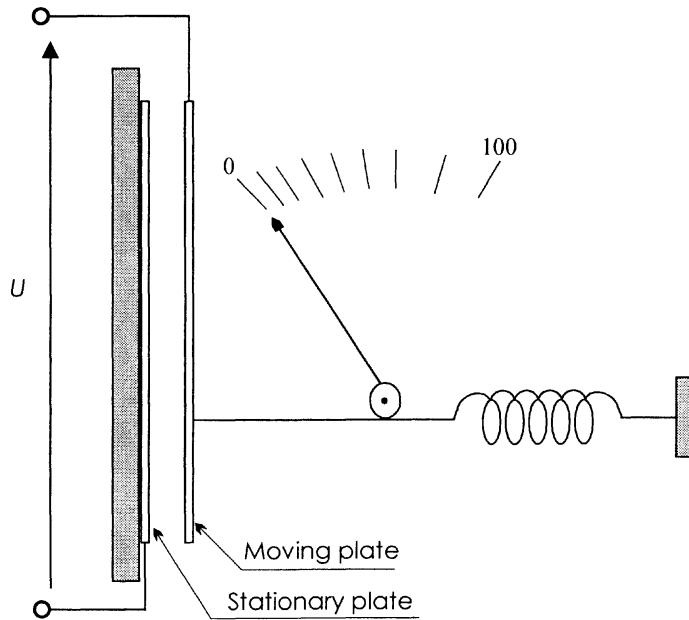

**FIGURE 37.6** Basic structure of an electrostatic voltmeter.

of the coils themselves and the series resistor. This last condition determines the upper limit of the input voltage frequency.

These voltmeters feature good accuracy (their uncertainty can be as low as 0.2% of the full-scale value), with full-scale values up to a few hundred volts, in a frequency range up to 2 kHz.

### Electrostatic Voltmeters

The action of electrostatic instruments is based on the force exerted between two charged conductors. The conductors behave as a variable plate air capacitor, as shown in [Figure 37.6](#). The moving plate, when charged, tends to move so as to increase the capacitance between the plates. The energy stored in the capacitor, when the applied voltage is  $U$  and the capacitance is  $C$ , is given by:

$$W = \frac{1}{2} CU^2 \quad (37.21)$$

This relationship is valid both under dc and ac conditions, provided that the voltage rms value  $U$  is considered for ac voltage.

When the moving plate is displaced horizontally by  $ds$ , while the voltage is held constant, the capacitor energy changes in order to equal the work done in moving the plate. The resulting force is:

$$F = \frac{dW}{ds} = \frac{U^2}{2} \frac{dC}{ds} \quad (37.22)$$

For a rotatable system, Equation 37.21 leads similarly to a resulting torque:

$$T = \frac{dW}{d\vartheta} = \frac{U^2}{2} \frac{dC}{d\vartheta} \quad (37.23)$$

If the action of a control spring is also considered, both Equations 37.22 and 37.23 show that the balance position of the moving plate is proportional to the square of the applied voltage, and hence electrostatic

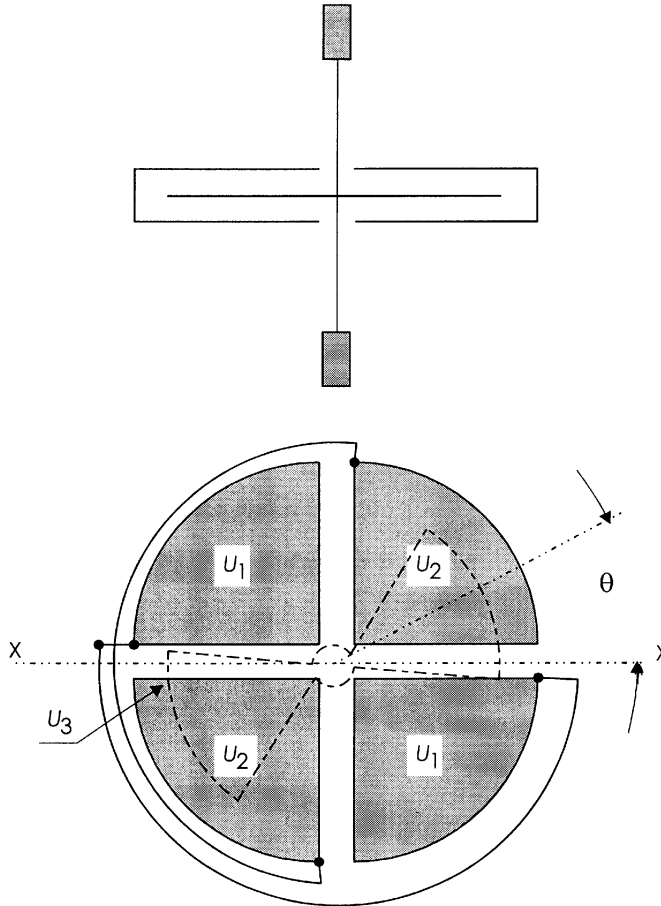

FIGURE 37.7 Quadrant electrometer structure.

voltmeters have a square-law scale. These equations, along with Equation 37.21, show that these instruments can be used for the measurement of both dc and ac rms voltages. However, the force (or torque) supplied by the instrument schematically represented in Figure 37.6 is generally very weak [2], so that its use is very impractical.

#### The Electrometer.

A more useful configuration is the quadrant electrometer, shown in Figure 37.7. Four fixed plates realize four quadrants and surround a movable vane suspended by a torsion fiber at the center of the system. The opposite quadrants are electrically connected together, and the potential difference ( $U_1 - U_2$ ) is applied. The moving vane can be either connected to potential  $U_1$  or  $U_2$ , or energized by an independent potential  $U_3$ .

Let the zero torque position of the suspension coincide with the symmetrical X-X position of the vane. If  $U_1 = U_2$ , the vane does not leave this position; otherwise, the vane will rotate.

Let  $C_1$  and  $C_2$  be the capacitances of quadrants 1 and 2, respectively, relative to the vane. They both are functions of  $\vartheta$  and, according to Equation 37.23, the torque applied to the vane is given by:

$$T = \frac{(U_3 - U_1)^2}{2} \frac{dC_1}{d\vartheta} + \frac{(U_3 - U_2)^2}{2} \frac{dC_2}{d\vartheta} \quad (37.24)$$

Since the vane turns out of one pair of quadrants as much as it turns into the other, the variations of  $C_1$  and  $C_2$  can be related by:

$$-\frac{dC_1}{d\vartheta} = \frac{dC_2}{d\vartheta} = k_1 \quad (37.25)$$

Taking into account the suspension restraining torque  $T_r = k_2\vartheta$ , the balance position can be obtained by Equations 37.24 and 37.25 as:

$$\vartheta = \frac{k_1}{2k_2} \left[ (U_3 - U_2)^2 - (U_3 - U_1)^2 \right] \quad (37.26)$$

If the vane potential  $U_3$  is held constant, and is large compared to the quadrant potentials  $U_1$  and  $U_2$ , Equation 37.26 can be simplified as follows:

$$\vartheta = \frac{k_1}{k_2} U_3 (U_1 - U_2) \quad (37.27)$$

Equation 37.27 shows that the deflection of the vane is directly proportional to the voltage difference applied to the quadrants. This method of use is called the *heterostatic* method.

If the vane is connected to quadrant 1,  $U_3 = U_1$  follows, and Equation 37.26 becomes

$$\vartheta = \frac{k_1}{2k_2} (U_1 - U_2)^2 \quad (37.28)$$

Equation 37.28 shows that the deflection of the vane is proportional to the square of the voltage difference applied to the quadrants, and hence this voltmeter has a square-law scale. This method of use is called the *idiostatic* method, and is suitable for the direct measurement of dc and ac voltages without an auxiliary power source.

The driving torque of the electrometer is extremely weak, as in all electrostatic instruments. The major advantage of using this kind of meter is that it allows for the measurement of dc voltages without drawing current by the voltage source under test. Now, due to the availability of operational amplifiers with extremely high input impedance, they have been almost completely replaced by electronic meters with high input impedance.

## Electronic Voltmeters

Electronic meters process the input signal by means of semiconductor devices in order to extract the information related to the required measurement [3, 4]. An electronic meter can be basically represented as a three-port element, as shown in [Figure 37.8](#).

The input signal port is an input port characterized by high impedance, so that the signal source has very little load. The measurement result port is an output port that provides the measurement result (in either an analog or digital form, depending on the way the input signal is processed) along with the power needed to energize the device used to display the measurement result. The power supply port is an input port which the electric power required to energize the meter internal devices and the display device flows through.

One of the main characteristics of an electronic meter is that it requires an external power supply. Although this may appear as a drawback of electronic meters, especially where portable meters are

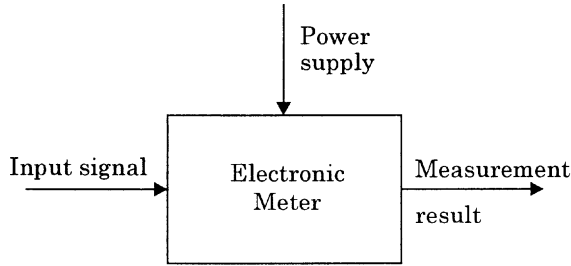

**FIGURE 37.8** Electronic meter.

concerned, note that, this way, the energy required for the measurement is no longer drawn from the signal source.

The high-level performance of modern electronic devices yields meters that are as accurate (and sometime even more accurate) as the most accurate electromechanical meters. Because they do not require the extensive use of precision mechanics, they are presently less expensive than electromechanical meters, and are slowly, but constantly, replacing them in almost all applications.

Depending on the way the input signal is processed, electronic meters are divided into *analog* and *digital* meters. Analog meters attain the required measurement by analog, continuous-time processing of the input signal. The measurement result can be displayed both in analog form using, for example, an electromechanical meter; or in digital form by converting the analog output signal into digital form. Digital meters attain the required measurement by digital processing of the input signal. The measurement result is usually displayed in digital form. Note that the distinction between analog and digital meters is not due to the way the measurement result is displayed, but to the way the input signal is processed.

### Analog Voltmeters

An electronic analog voltmeter is based on an electronic amplifier and an electromechanical meter to measure the amplifier output signal. The amplifier operates to make a dc current, proportional to the input quantity to be measured, flow into the meter. This meter is hence a dc moving-coil milliammeter.

Different full-scale values can be obtained using a selectable-ratio voltage divider if the input voltage is higher than the amplifier dynamic range, or by selecting the proper amplifier gain if the input voltage stays within the amplifier dynamic range.

The main features of analog voltmeters are high input impedance, high possible gain, and wide possible bandwidth for ac measurements. The relative measurement uncertainty can be lower than 1% of full-scale value. Because of these features, electronic analog voltmeters can have better performance than the electromechanical ones.

#### Dc Analog Voltmeters.

[Figure 37.9](#) shows the circuit for an electronic dc analog voltmeter. Assuming that the operational amplifier exhibits ideal behavior, current  $I_m$  flowing in the milliammeter A is given by:

$$I_m = I_o + I_2 = \frac{U_o}{R_o} + \frac{U_o}{R_2} = -U_i \frac{R_2}{R_1} \frac{R_2 + R_o}{R_2 R_o} = -\frac{U_i}{R_1} \left( 1 + \frac{R_2}{R_o} \right) \quad (37.29)$$

If  $R_1 = R_2$ , and the same resistances are far greater than  $R_o$ , Equation 37.29 can be simplified to:

$$I_m = -\frac{U_i}{R_o} \quad (37.30)$$

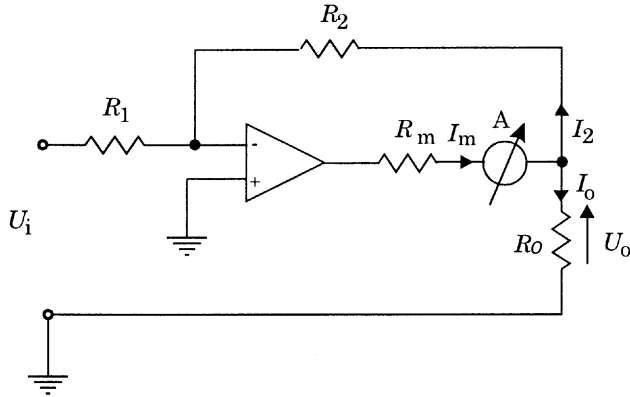

FIGURE 37.9 Electronic dc analog voltmeter schematics.

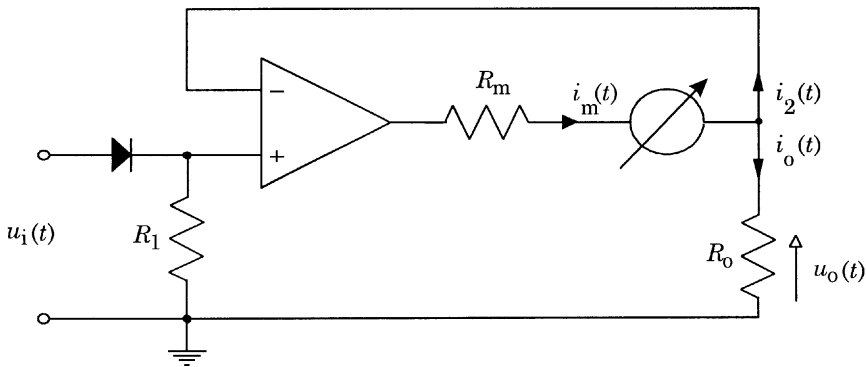

FIGURE 37.10 Electronic, rectifier-based ac analog voltmeter schematics.

Equation 37.30 shows that the millimeter reading is directly proportional to the input voltage through resistance  $R_o$  only. This means that, once the millimeter full-scale value is set, the voltmeter full-scale value can be changed, within the dynamic range of the amplifier, by changing the  $R_o$  value. This way, the meter full-scale value can be changed without changing its input impedance.

#### Rectifier-Based ac Analog Voltmeters.

Analog meters for ac voltages can be obtained starting from the dc analog voltmeters, with a rectifying input stage. Figure 37.10 shows how the structure in Figure 37.9 can be modified in order to realize an ac voltmeter.

Because of the high input impedance of the electronic amplifier,  $i_2(t) = 0$ , and the current  $i_m(t)$  flowing in the millimeter A is the same as current  $i_o(t)$  flowing in the load resistance. Since the amplifier is connected in a voltage-follower configuration, the output voltage is given by:

$$u_o(t) = u_i(t) \quad (37.31)$$

Due to the presence of the input diode, current  $i_m(t)$  is given by:

$$i_m(t) = \frac{u_i(t)}{R_o} \quad (37.32)$$

when  $u_i(t) > 0$ , and

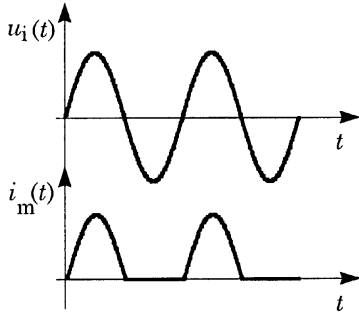

**FIGURE 37.11** Signal waveforms in a rectifier-based ac analog voltmeter when the input voltage is sinusoidal.

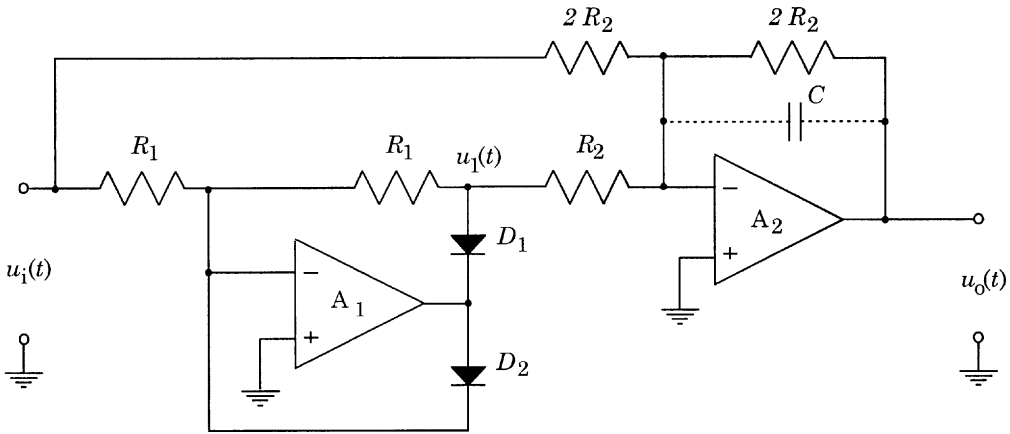

**FIGURE 37.12** Electronic, full-wave rectifier-based ac analog voltmeter schematics.

$$i_m(t) = 0 \tag{37.33}$$

when  $u_i(t) \leq 0$ . If  $u_i(t)$  is supposed to be a sine wave, the waveform of  $i_m(t)$  is shown in [Figure 37.11](#).

The dc moving-coil milliammeter measures the average value  $\bar{I}_m$  of  $i_m(t)$ , which, under the assumption of sinusoidal signals, is related to the rms value  $U_i$  of  $u_i(t)$  by:

$$\bar{I}_m = \frac{2\sqrt{2}}{\pi R_o} U_i \tag{37.34}$$

The performance of the structure in [Figure 37.10](#) can be substantially improved by considering the structure in [Figure 37.12](#) which realizes a full-wave rectifier. Because of the presence of diodes  $D_1$  and  $D_2$ , the output of amplifier  $A_1$  is given by:

$$u_1(t) = \begin{cases} -u_i(t) & \text{for } u_i(t) \geq 0 \\ 0 & \text{for } u_i(t) < 0 \end{cases} \tag{37.35}$$

where  $u_i(t)$  is the circuit input voltage.

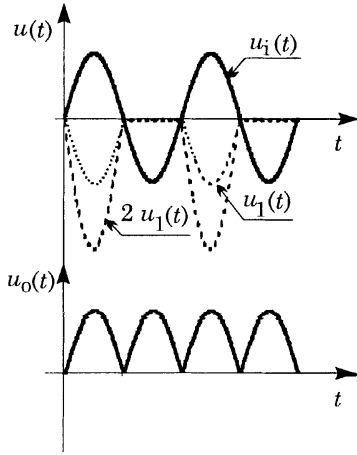

**FIGURE 37.13** Signal waveforms in a full-wave rectifier-based ac analog voltmeter when the input voltage is sinusoidal.

If capacitor  $C$  is supposed to be not connected, amplifier  $A_2$  output voltage is:

$$u_o(t) = -[u_1(t) + 2u_1(t)] \quad (37.36)$$

which gives:

$$u_o(t) = \begin{cases} u_1(t) & \text{for } u_1(t) \geq 0 \\ -u_1(t) & \text{for } u_1(t) < 0 \end{cases} \quad (37.37)$$

thus proving that the circuit in Figure 37.12 realizes a full-wave rectifier.

If  $u_i(t)$  is a sine wave, the waveforms of  $u_i(t)$ ,  $u_1(t)$  and  $u_o(t)$  are shown in [Figure 37.13](#).

Connecting capacitor  $C$  in the feedback loop of amplifier  $A_2$  turns it into a first-order low-pass filter, so that the circuit output voltage equals the average value of  $u_o(t)$ :

$$\bar{U}_o = \left| \overline{u_1(t)} \right| \quad (37.38)$$

In the case of sinusoidal input voltage with rms value  $U_i$ , the output voltage is related to this rms value by:

$$\bar{U}_o = \frac{2\sqrt{2}}{\pi} U_i \quad (37.39)$$

$\bar{U}_o$  can be measured by a dc voltmeter.

Both meters in Figures 37.10 and 37.12 are actually average detectors. However, due to Equations 37.34 and 37.39, their scale can be labeled in such a way that the instrument reading gives the rms value of the input voltage, provided it is sinusoidal. When the input voltage is no longer sinusoidal, an error arises that depends on the signal form factor.

**True rms Analog Voltmeters.**

The rms value  $U_i$  of a periodic input voltage signal  $u_i(t)$ , with period  $T$ , is given by:

$$U_i = \sqrt{\frac{1}{T} \int_0^T u_i^2(t) dt} \quad (37.40)$$



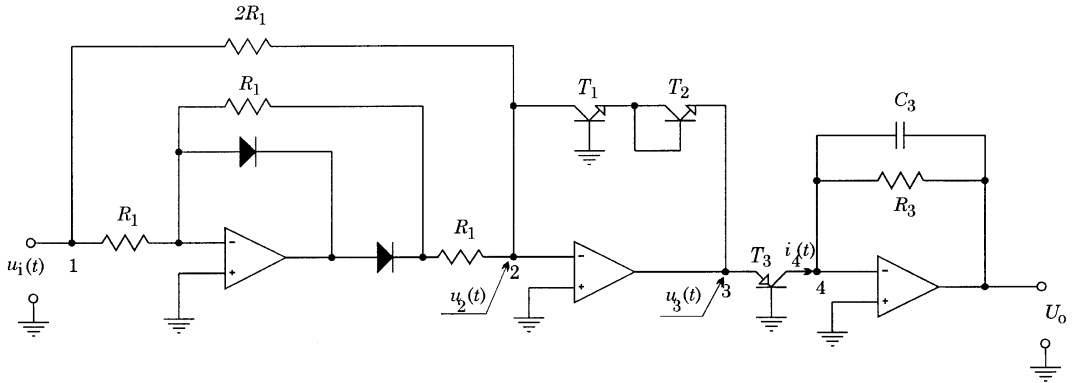

**FIGURE 37.14** True rms electronic ac voltmeter schematics.

The electronic circuit shown in [Figure 37.14](#) provides an output signal  $U_o$  proportional to the squared rms value of the input signal  $u_1(t)$ . The circuit section between nodes 1 and 2 is a full-wave rectifier. Hence, node 2 potential is given by:

$$u_2(t) = |u_1(t)| \quad (37.41)$$

The circuit section between nodes 2 and 4 is a log multiplier. Because of the logarithmic characteristic of the feedback path due to the presence of T1 and T2, node 3 potential is given by:

$$u_3(t) = 2k_1 \log[u_2(t)] = k_1 \log[u_2^2(t)] = k_1 \log[u_1(t)^2] = k_1 \log[u_1^2(t)] \quad (37.42)$$

and, due to the presence of T<sub>3</sub>, the current flowing in node 4 is given by:

$$i_4(t) = k_2 \exp[u_3(t)] = k_3 u_1^2(t) \quad (37.43)$$

The circuit section after node 4 is a low-pass filter that extracts the dc component of the input signal. Therefore, the circuit output voltage is given by:

$$U_o = \frac{k}{T} \int_0^T u_1^2(t) dt = k U_i^2 \quad (37.44)$$

thus providing an output signal proportional to the squared rms value of the input signal  $u_1(t)$  in accordance with Equation 37.40. Quantities  $k_1$ ,  $k_2$ , and  $k$  depend on the values of the elements in the circuit in [Figure 37.14](#). Under circuit operating conditions, their values can be considered constant, so that  $k_1$ ,  $k_2$ , and  $k$  can be considered constant also.

If carefully designed, this circuit can feature an uncertainty in the range of  $\pm 1\%$  of full scale, for signal frequencies up to 100 kHz.

### Digital Voltmeters

A digital voltmeter (DVM) attains the required measurement by converting the analog input signal into digital, and, when necessary, by discrete-time processing of the converted values. The measurement result is presented in a digital form that can take the form of a digital front-panel display, or a digital output signal. The digital output signal can be coded as a decimal BCD code, or a binary code.

The main factors that characterize DVMs are speed, automatic operation, and programmability. In particular, they presently offer the best combination of speed and accuracy if compared with other available voltage-measuring instruments. Moreover, the capability of automatic operations and programmability make DVMs very useful in applications where flexibility, high speed and computer controllability are required. A typical application field is therefore that of automatically operated systems.

When a DVM is directly interfaced to a digital signal processing (DSP) system and used to convert the analog input voltage into a sequence of sampled values, it is usually called an analog-to-digital converter (ADC).

DVMs basically differ in the following ways: (1) number of measurement ranges, (2) number of digits, (3) accuracy, (4) speed of reading, and (5) operating principle.

The basic measurement ranges of most DVMs are either 1 V or 10 V. It is however possible, with an appropriate preamplifier stage, to obtain full-scale values as low as 0.1 V. If an appropriate voltage divider is used, it is also possible to obtain full-scale values as high as 1000 V.

If the digital presentation takes the form of a digital front-panel display, the measurement result is presented as a decimal number, with a number of digits that typically ranges from 3 to 6. If the digital representation takes the form of a binary-coded output signal, the number of bits of this representation typically ranges from 8 to 16, though 18-bit ADCs are available.

The accuracy of a DVM is usually correlated to its resolution. Indeed, assigning an uncertainty lower than the 0.1% of the range to a three-digit DVM makes no sense, since this is the displayed resolution of the instrument. Similarly, a poorer accuracy makes the three-digit resolution quite useless. Presently, a six-digit DVM can feature an uncertainty range, for short periods of time in controlled environments, as low as the 0.0015% of reading or 0.0002% of full range.

The speed of a DVM can be as high as 1000 readings per second. When the ADC is considered, the conversion rate is taken into account instead of the speed of reading. Presently, the conversion rate for 12-bit, successive approximation ADCs can be on the order of 10 MHz. It can be in the order of 100 MHz for lower resolution, flash ADCs [5].

DVMs can be divided into two main operating principle classes: the *integrating* types and the *nonintegrating* types [3]. The following sections give an example for both types.

#### Dual Slope DVM.

Dual slope DVMs use a counter and an integrator to convert an unknown analog input voltage into a ratio of time periods multiplied by a reference voltage. The block diagram in Figure 37.15 shows this operating principle. The switch S1 connects the input signal to the integrator for a fixed period of time  $t_i$ . If the input voltage is positive and constant,  $u_i(t) = U_i > 0$ , the integrator output represents a negative-slope ramp signal (Figure 37.16). At the end of  $t_i$ , S1 switches and connects the output of the voltage reference  $U_R$  to the integrator input. The voltage reference output is negative for a positive input voltage. The integrator output starts to increase, following a positive-slope ramp (Figure 37.16). The process stops when the ramp attains the 0 V level, and the comparator allows the control logic to switch S1 again. The period of time  $t_v$  the ramp takes to increase to 0 V is variable and depends on the ramp peak value attained during period  $t_i$ .

The relationship between the input voltage  $U_i$  and the time periods  $t_v$  and  $t_i$  is given by:

$$\frac{1}{RC} \int_0^{t_i} U_i dt = \frac{t_v}{RC} U_R \quad (37.45)$$

that, for a constant input voltage  $U_i$ , leads to:

$$U_i = U_R \frac{t_v}{t_i} \quad (37.46)$$

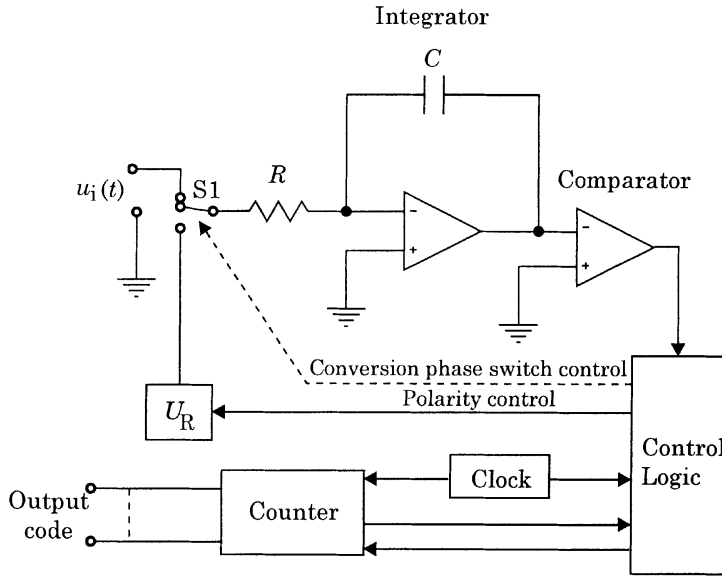

**FIGURE 37.15** Dual slope DVM schematics.

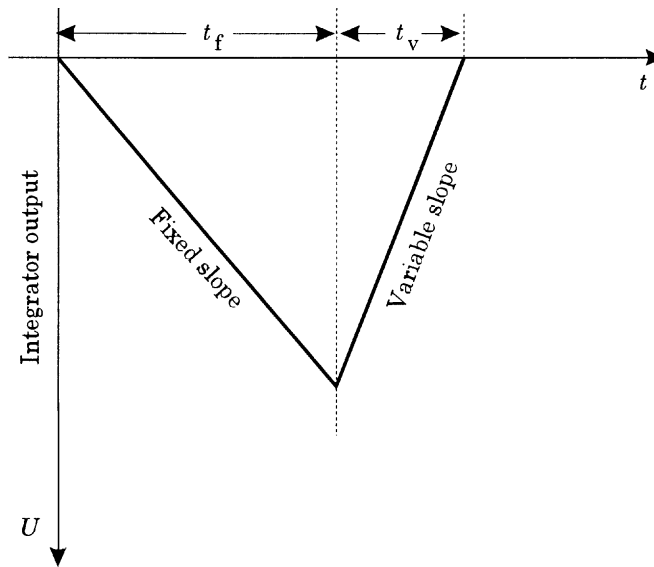

**FIGURE 37.16** Integrator output signal in a dual slope DVM.

Since the same integrating circuit is used, errors due to comparator offset, capacitor tolerances, long-term counter clock drifts, and integrator nonlinearities are eliminated. High resolutions are therefore possible, although the speed of reading is low (in the order of milliseconds).

Slowly varying voltages can be also measured by dual slope DVMs. However, this requires that the input signal does not vary for a quantity greater than the DVM resolution during the reading time. For high-resolution DVMs, this limits the DVM bandwidth to a few hertz.

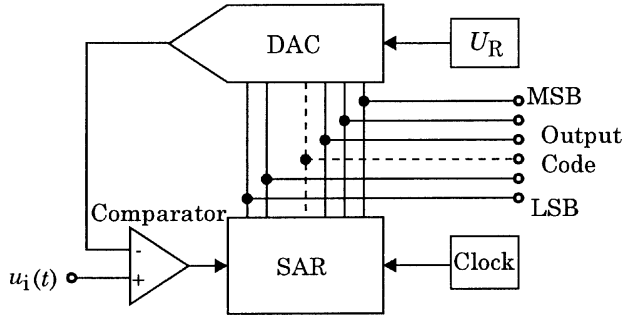

**FIGURE 37.17** Successive approximation ADC schematics.

### Successive Approximation ADC.

The successive approximation technique represents the most popular technique for the realization of ADCs. Figure 37.17 shows the block diagram of this type of converter. The input voltage is assumed to have a constant value  $U_i$  and drives one input of the comparator. The other comparator's input is driven by the output of the digital-to-analog converter (DAC), which converts the binary code provided by the successive approximation register (SAR) into an analog voltage. Let  $n$  be the number of bits of the converter,  $U_R$  the voltage reference output, and  $C$  the code provided by the SAR. The DAC output voltage is then given by:

$$U_c = \frac{C}{2^n} U_R \quad (37.47)$$

When the conversion process starts, the SAR most significant bit (MSB) is set to logic 1. The DAC output, according to Equation 37.47, is set to half the reference value, and hence half the analog input full-scale range. The comparator determines whether the DAC output is above or below the input signal. The comparator output controls the SAR in such a way that, if the input signal is above the DAC output, as shown in Figure 37.18, the SAR MSB is retained and the next bit is set to logic 1.

If now the input signal is below the DAC output (Figure 37.18), the last SAR bit set to logic 1 is reset to logic 0, and the next one is set to logic 1. The process goes on until the SAR least significant bit (LSB) has been set. The entire conversion process takes time  $t_c = nT_c$ , where  $T_c$  is the clock period. At the end of conversion, the SAR output code represents the digitally converted value of the input analog voltage  $U_i$ .

According to Equation 37.47, the ADC resolution is  $U_R/2^n$ , which corresponds to 1 LSB. The conversion error can be kept in the range  $\pm 1/2$  LSB. Presently, a wide range of devices is available, with resolution from 8 to 16 bits, and conversion rates from 100  $\mu$ s to below 1  $\mu$ s.

Varying voltages can be sampled and converted into digital by the ADC, provided the input signal does not vary by a quantity greater than  $U_R/2^n$  during the conversion period  $t_c$ . The maximum frequency of an input sine wave that satisfies this condition can be readily determined starting from given values of  $n$  and  $t_c$ .

Let the input voltage of the ADC be an input sine wave with peak-to-peak voltage  $U_{pp} = U_R$  and frequency  $f$ . Its maximum variation occurs at the zero-crossing time and, due to the short conversion period  $t_c$ , is given by  $2\pi f t_c U_{pp}$ . To avoid conversion errors, it must be:

$$2\pi f t_c U_{pp} \leq \frac{U_R}{2^n} \quad (37.48)$$

Since  $U_{pp} = U_R$  is assumed, this leads to:

$$f \leq \frac{1}{2^n 2\pi t_c} \quad (37.49)$$

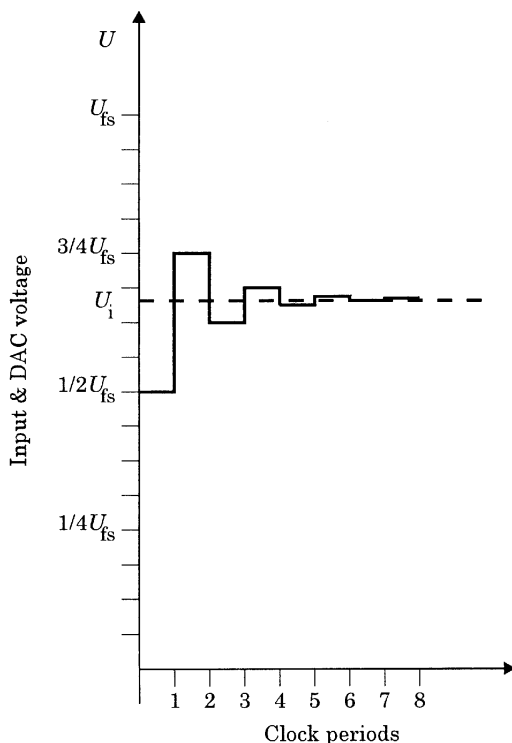

**FIGURE 37.18** DAC output signal in a successive approximation ADC.

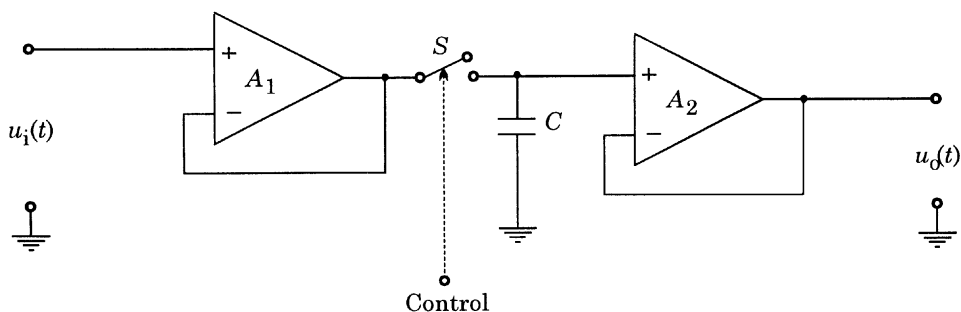

**FIGURE 37.19** Sample and Hold schematics

If  $t_c = 1 \mu\text{s}$  and  $n = 12$ , Equation 37.49 leads to  $f \leq 38.86 \text{ Hz}$ . However, ADCs can still be employed with input signals whose frequency exceeds the value given by Equation 37.49, provided that a *Sample and Hold* circuit is used to keep the input voltage constant during the conversion period.

The *Sample and Hold* circuit is shown in Figure 37.19. When the electronic switch  $S$  is closed, the output voltage  $u_o(t)$  follows the input voltage  $u_i(t)$ . When switch  $S$  is open, the output voltage is the same as the voltage across capacitor  $C$ , which is charged at the value assumed by the input voltage at the time the switch was opened. Due to the high input impedance of the operational amplifier  $A_2$ , if a suitable value is chosen for capacitor  $C$ , its discharge transient is slow enough to keep the variation of the output voltage below the ADC resolution.

#### Ac Digital Voltmeters.

True rms ac voltmeters with digital reading can be obtained using an electronic circuit like the one in Figure 37.14 to convert the rms value into a dc voltage signal, and measuring it by means of a DVM.

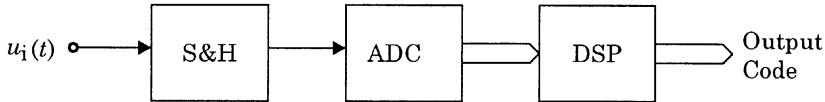

**FIGURE 37.20** Block diagram of a modern digital meter.

However, this structure cannot actually be called a digital structure, because the measurement is attained by means of analog processing of the input signal.

A more modern approach, totally digital, is shown in Figure 37.20. The input signal  $u_i(t)$  is sampled at constant sampling rate  $f_s$ , and converted into digital by the ADC. The digital samples are stored in the memory of the digital signal processor (DSP) and then processed in order to evaluate Equation 37.40 in a numerical way. Assuming that the input signal is periodic, with period  $T$ , and its frequency spectrum is upper limited by harmonic component of order  $N$ , the sampling theorem is satisfied if at least  $(2N + 1)$  samples are taken over period  $T$  in such a way that  $(2N + 1)T_s = T$ ,  $T_s = 1/f_s$  being the sampling period [6, 7]. If  $u_i(kT_s)$  is the  $k^{\text{th}}$  sample, the rms value of the input signal is given by, according to Equation 37.40:

$$U^2 = \sqrt{\frac{1}{2N+1} \sum_{k=0}^{2N} u_i^2(kT_s)} \quad (37.50)$$

This approach can feature a relative uncertainty as low as  $\pm 0.1\%$  of full scale, with an ADC resolution of 12 bits. The instrument bandwidth is limited to half the sampling frequency, according to the sampling theorem. When modern ADCs and DSPs are employed, a 500-kHz bandwidth can be obtained. Wider bandwidths can be obtained, but with a lower ADC resolution, and hence with a lower accuracy.

#### Frequency Response of ac Voltmeters.

When the frequency response of ac voltmeters is taken into account, a distinction must be made between the analog voltmeters (both electromechanical and electronic) and digital voltmeters, based on DSP techniques.

The frequency response of the analog meters is basically a low-pass response, well below 1 kHz for most electromechanical instruments, and up to hundreds of kilohertz for electronic instruments.

When digital, DSP-based meters are concerned, the sampling theorem and aliasing effects must be considered. To a first approximation, the frequency response of a digital meter can be considered flat as long as the frequency-domain components of the input signal are limited to a frequency band narrower than half the sampling rate. If the signal components exceed this limit (the so-called Nyquist frequency), the aliasing phenomenon occurs [6]. Because of this phenomenon, the signal components at frequencies higher than half the sampling rate are folded over the lower frequency components, changing them. Large measurement errors occur under this situation.

To prevent the aliasing, a low-pass filter must be placed at the input stage of any digital meter. The filter cut-off frequency must ensure that all frequency components above half the sampling rate are negligible. If the low-pass, anti-aliasing filter is used, the digital DSP-based meters feature a low-pass frequency response also.

## References

1. M. B. Stout, *Basic Electrical Measurements*, Englewood Cliffs, NJ, Prentice-Hall, 1960.
2. I. F. Kinnard, *Applied Electrical Measurements*, New York, John Wiley & Sons, Chapman & Hall, Ltd. London, 1956.
3. B. M. Oliver and J. M. Cage, *Electronic Measurements and Instrumentation*, London, McGraw-Hill, Inc. 1975.
4. T. T. Lang, *Electronics of Measuring Systems*, New York, John Wiley & Sons, 1987.
5. Analog Devices, *Analog-Digital Conversion Handbook*, Englewood Cliffs, NJ, Prentice-Hall, 1986.

6. A. V. Oppenheim and R. W. Schaffer, *Digital Signal Processing*, Englewood Cliffs, NJ, Prentice-Hall, 1975.
7. A. Ferrero and R. Ottoboni, High-accuracy Fourier analysis based on synchronous sampling techniques. *IEEE Trans. Instr. Meas.*, 41(6), 780-785, 1992.

## 37.2 Oscilloscope Voltage Measurement

---

*Jerry Murphy*

Engineers, scientists, and other technical professionals around the world depend on oscilloscopes as one of the primary voltage measuring instruments. This is an unusual situation because the oscilloscope is not the most accurate voltage measuring instrument usually available in the lab. It is the graphical nature of the oscilloscope that makes it so valued as a measurement instrument — not its measurement accuracy.

The oscilloscope is an instrument that presents a graphical display of its input voltage as a function of time. It displays voltage waveforms that cannot easily be described by numerical methods. For example, the output of a battery can be completely described by its output voltage and current. However, the output of a more complex signal source needs additional information such as frequency, duty cycle, peak-to-peak amplitude, overshoot, preshoot, rise time, fall time, and more to be completely described. The oscilloscope, with its graphical presentation of complex waveforms, is ideally suited to this task. It is often described as the “screwdriver of the electronic engineer” because the oscilloscope is the most fundamental tool that technical professionals apply to the problem of trying to understand the details of the operation of their electronic circuit or device. So, what is an oscilloscope?

The oscilloscope is an electronic instrument that presents a high-fidelity graphical display of the rapidly changing voltage at its input terminals.

The most frequently used display mode is voltage vs. time. This is not the only display that could be used, nor is it the display that is best suited for all situations. For example, the oscilloscope could be called on to produce a display of two changing voltages plotted one against the other, such as a Lissajous display. To accurately display rapidly changing signals, the oscilloscope is a high bandwidth device. This means that it must be capable of displaying the high-order harmonics of the signal being applied to its input terminals in order to correctly display that signal.

### The Oscilloscope Block Diagram

The oscilloscope contains four basic circuit blocks: the vertical amplifier, the time base, the trigger, and the display. This section treats each of these in a high-level overview. Many textbooks exist that cover the details of the design and construction of each of these blocks in detail [1]. This discussion will cover these blocks in enough detail so that readers can construct their own mental model of how their operation affects the application of the oscilloscope for their voltage measurement application. Most readers of this book have a mental model of the operation of the automatic transmission of an automobile that is sufficient for its successful operation but not sufficient for the overhaul or redesign of that component. It is the goal of this section to instill that level of understanding in the operation of the oscilloscope. Those readers who desire a deeper understanding will get their needs met in later sections.

Of the four basic blocks of the oscilloscope, the most visible of these blocks is the display with its *cathode-ray tube* (CRT). This is the component in the oscilloscope that produces the graphical display of the input voltage and it is the component with which the user has the most contact. [Figure 37.21](#) shows the input signal is applied to the vertical axis of a cathode ray tube. This is the correct model for an analog oscilloscope but it is overly simplified in the case of the digital oscilloscope. The important thing to learn from this diagram is that the input signal will be operated on by the oscilloscope’s vertical axis circuits so that it can be displayed by the CRT. The differences between the analog and digital oscilloscope are covered in later sections.

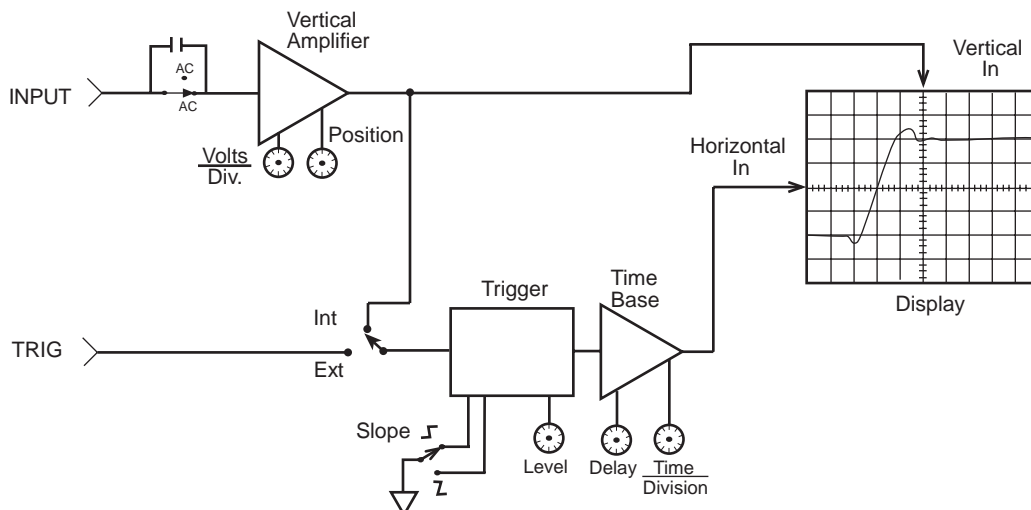

**FIGURE 37.21** Simplified oscilloscope block diagram that applies to either analog or digital oscilloscopes. In the case of the digital oscilloscope, the vertical amplifier block will include the ADC and high-speed waveform memory. For the analog scope the vertical block will include delay lines with their associated drivers and a power amplifier to drive the CRT plates.

The *vertical amplifier* conditions the input signal so that it can be displayed on the CRT. The vertical amplifier provides controls of volts per division, position, and coupling, allowing the user to obtain the desired display. This amplifier must have a high enough bandwidth to ensure that all of the significant frequency components of the input signal reach the CRT.

The *trigger* is responsible for starting the display at the same point on the input signal every time the display is refreshed. It is the stable display of a complex waveform that allows the user of an oscilloscope to make judgments about that waveform and its implications as to the operation of the device under test.

The final piece of the simplified block diagram is the *time base*. This circuit block is also known as the horizontal system in some literature. The time base is the part of the oscilloscope that causes the input signal to be displayed as a function of time. The circuitry in this block causes the CRT beam to be deflected from left to right as the input signal is being applied to the vertical deflection section of the CRT. Controls for time-per-division and position (or delay) allow the user of the oscilloscope to adjust the display for the most useful display of the input signal. The time-per-division controls of most oscilloscopes provide a wide range of values, ranging from a few nanoseconds ( $10^{-9}$  s) to seconds per division. To get a feeling for the magnitude of the dynamic range of the oscilloscope's time base settings, keep in mind that light travels about 1 m in 3 ns.

## The Oscilloscope As a Voltage Measurement Instrument

That the oscilloscope's vertical axis requires a wide bandwidth amplifier and its time base is capable of displaying events that are as short as a few nanoseconds apart, indicates that the oscilloscope can display rapidly changing voltages. Voltmeters, on the other hand, are designed to give their operator a numeric readout of steady-state or slowly changing voltages. Voltmeters are not well suited for displaying voltages that are changing levels very quickly. This can be better understood by examination of the operation of a voltmeter as compared to that of an oscilloscope. The analog voltmeter uses the magnetic field produced by current flowing through a coil to move the pointer against the force of a spring. This nearly linear deflection of the voltmeter pointer is calibrated by applying known standard voltages to its input.



Therefore, if a constant voltage is applied to the coil, the pointer will move to a point where the magnetic force being produced by the current flowing in its coil is balanced by the force of the spring. If the input voltage is slowly changing, the pointer will follow the changing voltage. This mechanical deflection system limits the ability of this measurement device to the measurement of steady-state or very low-frequency changes in the voltage at its input terminals. Higher-frequency voltmeters depend on some type of conversion technique to change higher frequencies to a dc signal that can be applied to the meter's deflection coil. For example, a diode is used to rectify ac voltages to produce a dc voltage that corresponds to the average value of the ac voltage at the input terminals in average responding ac voltmeters.

The digital voltmeter is very much like the analog meter except that the mechanical displacement of the pointer is replaced with a digital readout of the input signal. In the case of the digital voltmeter, the input signal is applied to an analog-to-digital converter (ADC) where it is compared to a reference voltage and digitized. This digital value of the input signal is then displayed in a numerical display. The ADC techniques applied to voltmeters are designed to produce very accurate displays of the same signals that were previously measured with analog meters. The value of a digital voltmeter is its improved measurement accuracy as compared to that of its analog predecessors.

The oscilloscope will display a horizontal line displaced vertically from its zero-voltage level when a constant, or dc voltage is applied to its input terminals. The magnitude of this deflection of the oscilloscope's beam vertically from the point where it was operating with no input being applied is how the oscilloscope indicates the magnitude of the dc level at its input terminals. Most oscilloscopes have a graticule as a part of their display and the scope's vertical axis is calibrated in volts per division of the graticule. As one can imagine, this is not a very informative display of a dc level and perhaps a voltmeter with its numeric readout is better suited for such applications.

There is more to the scope-voltmeter comparison than is obvious from the previous discussion. That the oscilloscope is based on a wide-bandwidth data-acquisition system is the major difference between these two measurement instruments. The oscilloscope is designed to produce a high fidelity display of rapidly changing signals. This puts additional constraints on the design of the oscilloscope's vertical system that are not required in the voltmeter. The most significant of these constraints is that of a constant group delay. This is a rather complex topic that is usually covered in network analysis texts. It can be easily understood if one realizes the effect of group delay on a complex input signal.

Figure 37.22 shows such a signal. The amplitude of this signal is a dc level and the rising edge is made up of a series of high-frequency components. Each of these high-frequency components is a sine wave of specific amplitude and frequency. Another example of a complex signal is a square wave with a frequency of 10 MHz. This signal is made up of a series of odd harmonics of that fundamental frequency. These harmonics are sine waves of frequencies of 10 MHz, 30 MHz, 50 MHz, 70 MHz, etc. So, the oscilloscope must pass all of these high-frequency components to the display with little or no distortion. Group delay is the measure of the propagation time of each component through the vertical system. A constant group delay means that each of these components will take the same amount of time to propagate through the vertical system to the CRT, independent of their frequencies. If the higher-order harmonics take more or less time to reach the scope's deflection system than the lower harmonics, the resulting display will be a distorted representation of the input signal. Group delay (in seconds) is calculated by taking the first derivative of an amplifier's phase-vs.-frequency response (in radians/(l/s)). If the amplifier has a linearly increasing phase shift with frequency, the first derivative of its phase response will be a horizontal line corresponding to the slope of the phase plot (in seconds). Amplifier systems that have a constant group delay are known as Gaussian amplifiers. They have this name because their pass band shape resembles that of the bell curve of a Gaussian distribution function (Figure 37.23). One would think that the oscilloscope's vertical amplifier should have a flat frequency response, but this is not the case because such amplifiers have nonconstant group delay [1].

The oscilloscope's bandwidth specification is based on the frequency where the vertical deflection will be  $-3$  dB (0.707) of the input signal. This means that if a constant 1-V sine wave is applied to the oscilloscope's input, and the signal's frequency is adjusted to higher and higher frequencies, the oscilloscope's bandwidth will be that frequency where its display of the input signal has been reduced to be

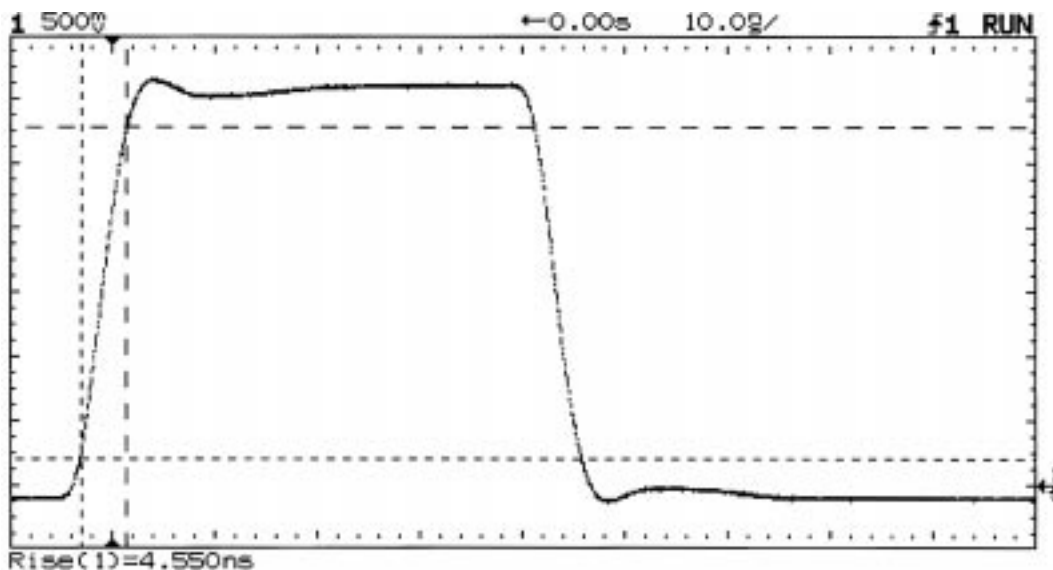

**FIGURE 37.22** A typical complex waveform. This waveform is described by measurements of its amplitude, offset, risetime, falltime, overshoot, preshoot, and droop.

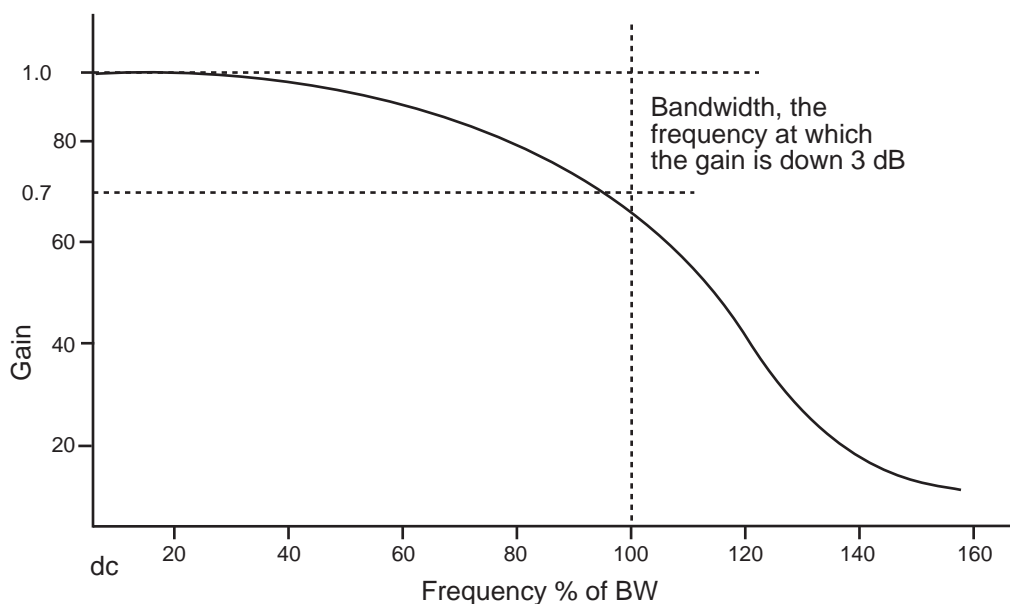

**FIGURE 37.23** The Gaussian frequency response of the oscilloscope's vertical system which is not flat in its pass band. Amplitude measurements made at frequencies greater than 20% of the scope's bandwidth will be in error.

0.707 V. Noticeable errors in amplitude measurements will start at 20% of the scope's bandwidth. The oscilloscope's error-free display of complex waveforms gives it poor voltage accuracy. For the measurement of dc and single frequency signals such as sine waves, other instruments can produce more accurate measurements.

*Conclusion:* The voltmeter makes the most accurate measurements of voltages that are dc, slowly changing, or can be converted to a dc analog of their ac content. The oscilloscope is not the most accurate voltage measurement instrument, but it is well suited to measurements of voltages that are changing very

rapidly as a function of time. Oscilloscopes are the instrument of choice for observing and characterizing these complex voltages.

## Analog or Digital

The world of oscilloscopes is divided into two general categories: analog and digital. The first oscilloscopes were analog. These products are based on the direct-view vector cathode-ray tube (DVVCRT or CRT for short). The analog oscilloscope applies the input signal to the vertical deflection plates of the CRT where it causes the deflection of a beam of high-energy electrons moving toward the phosphor-coated faceplate. The electron beam generates a lighted spot where it strikes the phosphor. The intensity of the light is directly related to the density of the electrons hitting a given area of the phosphor. Because this analog operation is not based on any digitizing techniques, most people have little trouble creating a very accurate and simple mental model in their minds of its operation.

The analog oscilloscope produces a display of the input signal that is bright and easy to see under most conditions. It can also contain as many as 16 shades of gray-scale information. This means that an event that occurs less frequently will appear at a lower intensity in the display than another event that occurs more frequently. This oscilloscope does not produce a continuous display of the input signal. It is blind during retrace and trigger hold-off times. Because the display depends on the production of visible light from the phosphor being excited by an electron beam, the display must be refreshed frequently. This makes the analog oscilloscope a low-dead-time display system that can follow rapidly changing signals. Also, there is little lag time in front panel control settings.

The analog oscilloscope is not without its shortcomings. The strength of the analog oscilloscope is its CRT, but this is also the source of its weaknesses. The biggest problem with analog scopes is their dependence on a display that is constantly being refreshed. This means that these scopes do not have any waveform storage. If the input signal fails to repeat frequently, the display will simply be a flash of light when the beam sweeps by the phosphor. If the signal's repetition rate falls below 100 Hz, the display will flicker annoyingly. [Figure 37.24](#) shows a plot of the range of an input signal's repetition frequency range from a single-shot event to the full bandwidth of a scope vs. the scope's sweep speeds. The result is a map of the scope's operational area. [Figure 37.24](#) shows that the analog oscilloscope fails to map onto the full range of possible input signals and sweep speeds.

Another problem of the analog oscilloscope is its inability to display information ahead of its trigger. This is a problem in applications where the only suitable trigger is at the end of the event of interest. Another limitation of analog scopes is their timing accuracy. The time base of the analog scope is based on the linearity of a voltage ramp. There are other sources of errors in the analog oscilloscope's horizontal axis, but the sweep nonlinearity is the major contributor. This results in these scopes having a timing accuracy of typically  $\pm 3\%$  of their full-scale setting. Therefore, if the time base is set to 100 ns/div, in order to view a 100-ns wide pulse, the full scale will be 1000 ns or 1  $\mu$ s. The accuracy of this pulse width measurement will be  $\pm 30$  ns or  $\pm 30\%$  of the pulse width!

The digital oscilloscope or digital storage oscilloscope (DSO) differs from its analog counterpart in that the input signal is converted to digital data and therefore it can be managed by an embedded microprocessor. The waveform data can have correction factors applied to remove errors in the scope's acquisition system and can then be stored, measured, and/or displayed. That the input signal is converted from analog to digital and manipulations are performed on it by a microprocessor results in people not having a good mental model of the digital oscilloscope's operation. This would not be a problem except for the fact that the waveform digitizing process is not totally free from errors, and a lack of a correct mental model of the scope's operation on the part of its user can increase the odds of a measurement error. To make matters worse, various manufacturers of these products make conflicting claims, making it easy to propagate incorrect mental models of the digital scope's operation. It is the intention of this presentation to give the information needed to create a mental model of the operation of these devices that will enable the user to perform error-free measurements with ease.

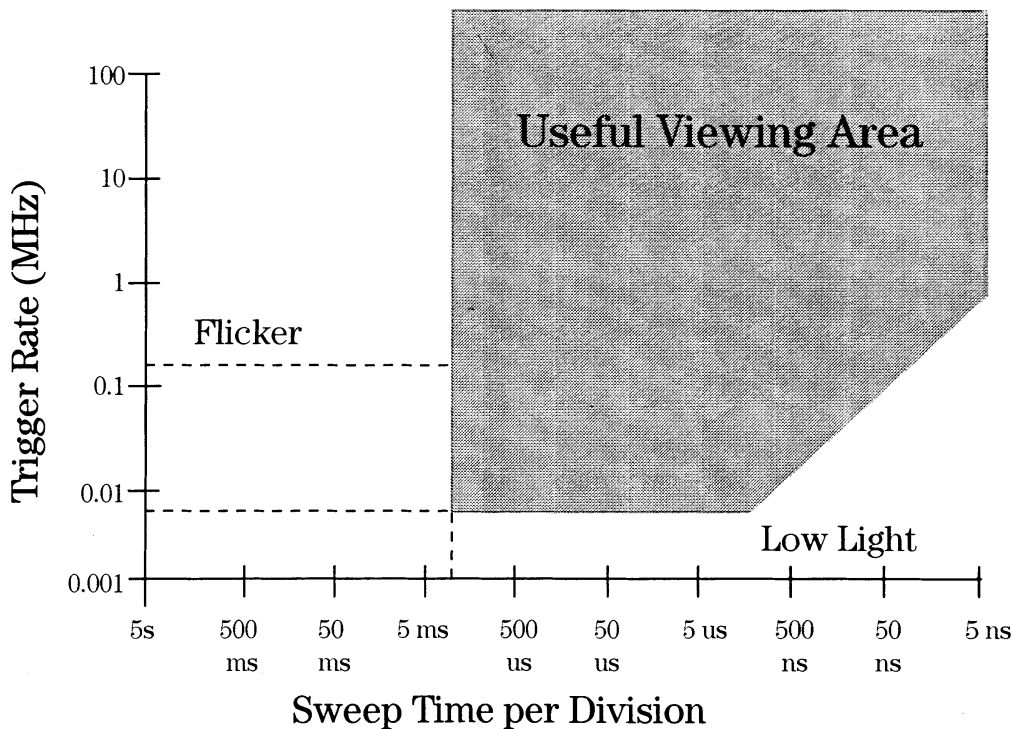

**FIGURE 37.24** The operating range of the analog oscilloscope. This is a plot of input signal repetition rate from the lower limit of single shot to the full bandwidth of the scope plotted against sweep speed. The shaded area is the area where the analog oscilloscope will produce a usable display.

The digital storage oscilloscope offers many advantages over its analog counterpart. The first is accuracy. The voltage measurement accuracy of the digital oscilloscope is better than that of an analog scope because the microprocessor can apply correction factors to the data to correct for errors in the calibration of the scope's vertical system. The timing accuracy of a digital oscilloscope is an order of magnitude better than that of an analog scope. The digital scope can store the waveform data for comparison to other test results or uploading to a computer for analysis or project documentation. The digital oscilloscope does not depend on the input signal being continuously updated to produce an easily viewable display. A single-shot event is displayed at the same brightness level as a signal that repeats in time periods corresponding to the full bandwidth of the scope.

The disadvantages of the digital oscilloscope are its more complex operation, aliasing, and display performance. The analog-to-digital conversion process [1] is used to convert the input signal into a series of discrete values, or samples, uniformly spaced in time, which can be stored in memory. Voltage resolution is determined by the total number of codes that can be produced. A larger number permits a smoother and more accurate reproduction of the input waveform but increases both the cost and difficulty in achieving a high sample frequency. Most digital oscilloscopes provide 8-bit resolution in their ADC. As the ADC's sampling speed is increased, the samples will be closer together, resulting smaller gaps in the waveform record.

All digital scopes are capable of producing an aliased display. Some models are more prone to this problem than others, but even the best will alias under the right conditions. An alias is a lower frequency false reproduction of the input signal resulting from under-sampling, i.e., sampling less than the Nyquist frequency. The display of the digital scope is based on computer display technology. This results in a display that is very bright and easy to see, even under conditions where an analog scope would have difficulty in producing a viewable display. The disadvantage of the digital scope's display is its lower

**TABLE 37.2** A Comparison of Analog and Digital Oscilloscopes

	Analog Oscilloscope	Digital Oscilloscope
Operation	Simple	Complex
Front panel controls	Direct access knobs	Knobs and menus
Display	Real-time vector	Digital raster scan
Gray scales	>16	>4
Horizontal resolution	>1000 lines	500 lines
Dead-time	Short	Can be long
Aliasing	No	Yes
Voltage accuracy	$\pm 3\%$ of full scale	$\pm 3\%$ of full scale
Timing accuracy	$\pm 3\%$ of full scale	$\pm 0.01\%$ of full scale
Single shot capture	None	Yes
Glitch capture	Limited	Yes
Waveform storage	None	Yes
Pretrigger viewing	None	Yes
Data out to a computer	No	Yes

horizontal resolution. Most of the scopes on the market have a raster scan display with a resolution of 500 lines, less than half the resolution of an analog scope's display. This is not a problem in most applications. It could become a factor where very complex waveforms, such as those found in TV systems, are being analyzed. Many digital scopes have display systems that exhibit large dead- or blind-times. Scopes based on a single CPU will be able to display their waveform data only after the CPU has finished all of its operations. This can result a display that is unresponsive to front panel control inputs as well as not being able to follow changes in the input signal.

Table 37.2 shows that both analog and digital oscilloscopes have relative advantages and disadvantages. All the major producers of oscilloscopes are pushing the development of digital scopes in an attempt to overcome their disadvantages. All the major producers of these products believe that the future is digital. However, a few manufacturers produce scopes that are both analog and digital. These products appear to have the best of both worlds; however, they have penalties with respect to both cost and complexity of operation.

One of the driving forces making scope manufacturers believe that the future of the digital oscilloscope is bright is that modern electronic systems are becoming ever more digital in nature. Digital systems place additional demands on the oscilloscope that exceed the capabilities of the analog scope. For example, often in digital electronic systems, there is a need to view fast events that occur at very slow or infrequent rates. Figure 37.24 shows that these events fail to be viewable on analog scopes. Another common problem with digital systems is the location of trigger events. Often the only usable trigger is available at the end of the event being viewed. Analog scopes can only display events that occur after a trigger event. The rapid growth of digital electronics that in the late 1990s is being attributed to the lowering of the cost of single-chip microcontrollers. These devices, which contain a complete microprocessor on one integrated circuit, are responsible for the "electronics everywhere" phenomenon, where mechanical devices are becoming electronic as well as those devices that were previously electrical in nature. In 1996, Hewlett Packard introduced a new class of oscilloscope designed to meet the unique needs of the microcontroller-based applications. This new class of oscilloscope is known as the mixed signal oscilloscope or MSO [2].

## Voltage Measurements

Voltage measurements are usually based on comparisons of the waveform display to the oscilloscope's graticule. Measurements are made by counting the number of graticule lines between the end-points of the desired measurement and then multiplying that number by the sensitivity setting. This was the only measurement available to most analog scope users, and it is still used by those performing troubleshooting with their digital scope as a time-saving step. (Some late-model analog oscilloscopes incorporate cursors

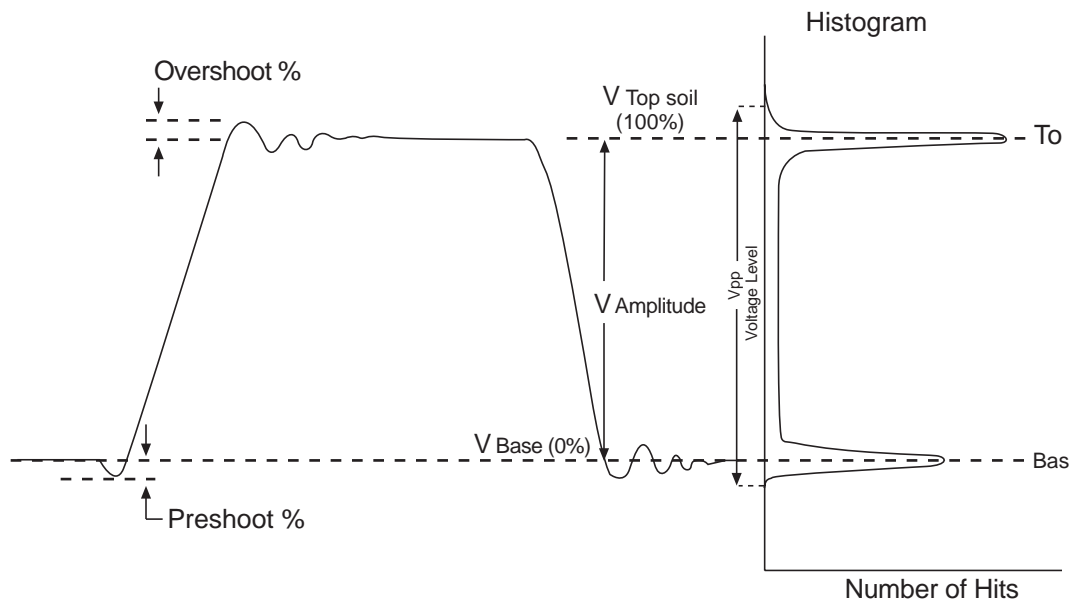

**FIGURE 37.25** Voltage histograms as applied by a digital oscilloscope. The complex waveform is measured by use of the voltage histogram. This histogram is a plot of each voltage level in the display and the number of data points at that level.

to enhance their measurement ability.) For example, a waveform that is 4.5 divisions high at a vertical sensitivity of 100 mV/div would be 450 mV high.

Switching the scope's coupling between ac and dc modes will produce a vertical shift in the waveform's position that is a measurement of its dc component. This technique can be applied to either analog or digital scopes. Simply note the magnitude of the change in waveform position and multiply by the channel's sensitivity.

Additional measurements can be performed with an analog oscilloscope but they usually require more skill on the part of the operator. For example, if the operator can determine the location of the top and base of a complex waveform, its amplitude can be measured. Measurements based on percentages can be made using the scope's vernier to scale the waveform so that its top and bottom are 5 divisions apart. Then, each division represents 20% of the amplitude of the waveform being studied. The use of the vernier, which results in the channel being uncalibrated, prevents performance of voltage measurements. Many analog scopes have a red light to warn the operator that the scope is uncalibrated when in vernier mode.

The digital oscilloscope contains an embedded microprocessor that automates the measurement. This measurement automation is based on a histogramming technique, where a histogram of all the voltage levels in the waveform are taken from the oscilloscope's waveform data. The histogram is a plot of the voltage levels in the waveform plotted against the number of samples found at each voltage level. [Figure 37.25](#) shows the histogramming technique being applied to the voltage measurements of complex waveforms.

## Understanding the Specifications

The oscilloscope's vertical accuracy is one place that a person's mental model of the scope's operation can lead to measurement trouble. For example, the oscilloscope's vertical axis has a frequency response that is not flat across its pass band. However, as noted above, the scope has a Gaussian frequency response

to produce the most accurate picture of complex signals. This means that the oscilloscope's accuracy specification of  $\pm 3\%$  is a dc-only specification. If one were to attempt to measure the amplitude of a signal whose frequency is equal to the bandwidth of the scope, one would have to add another 29.3% to the error term, for a total error of  $\pm 32.3\%$ . This is true for both analog and digital oscilloscopes. This limitation can be overcome by carefully measuring the frequency response of the oscilloscope's vertical channels. One will need to repeat this process every time the scope is serviced or calibrated, because the various high-frequency adjustments that may need to be made in the scope's vertical axis will affect the scope's frequency response. One is probably asking, why don't the manufacturers do this for me? The answer is twofold. The first is cost, and the second is that this is not the primary application of an oscilloscope. There are other instruments that are much better suited to the measurement of high-frequency signals. The spectrum analyzer would be this author's first choice.

Additionally, the vertical accuracy is a full-scale specification. This means that at 1 V/div, the full-scale value is typically 8 V. The measurement error for a scope with a  $\pm 3\%$  specification under these conditions will be  $\pm 0.24$  V. If the signal being measured is only 1 V high, the resulting measurement will be  $\pm 24\%$  of reading. Check the manual for the scope being used, as some manufacturers will specify full-scale as being 10 or even 10.2 divisions. This will increase the error term because the full-scale term is larger.

In digital oscilloscopes, the vertical accuracy is often expressed as a series of terms. These attempt to describe the analog and digital operations the scope performs on the input signal. Terms might include digitizing resolution, gain, and offset (sometimes called as position). They also might be called out as single and dual cursor accuracies. The single cursor accuracy is a sum of all three terms. In the dual cursor case, where the voltage measurement is made between two voltage cursors, the offset term will cancel out, leaving only the digitizing resolution and gain errors. For example, the Hewlett Packard model 54603B has a single cursor accuracy specification of  $\pm 1.2\%$  of full scale,  $\pm 0.5\%$  of position value, and a dual cursor specification of  $\pm 0.4\%$  of full scale.

**HINT:** Always try to make the voltage measurements on the largest possible vertical and widest possible display of the signal.

The horizontal accuracy specifications of analog and digital scopes are very different; however, both are based on a full-scale value. In the analog scope, many manufacturers limit accuracy specifications to only the center eight divisions of their display. This means that a measurement of a signal that starts or ends in either the first or ninth graticule, will be even more error prone than stated in the scope's specifications. To the best of this author's knowledge, this limitation does not apply to digital scopes. The horizontal specifications of digital scopes are expressed as a series of terms. These might include the crystal accuracy, horizontal display resolution, and trigger placement resolution. These can be listed as cursor accuracy. For example, the Hewlett Packard model 54603B has a horizontal cursor accuracy specification of  $\pm 0.01\% \pm 0.2\%$  full-scale  $\pm 200$  ps. In this example, the first term is the crystal accuracy, the second is the display resolution (500 lines), and the final term is twice the trigger placement error. By comparing the analog and digital scopes' horizontal specifications, it can be seen that in either case, the measurement is more accurate if it can be made at full screen. The digital scope is more accurate than its analog counterpart.

Digital scopes also have acquisition system specifications. Here is another place where the operator's mental model of the operation of a digital scope can produce measurement errors. All manufacturers of digital scopes specify the maximum sampling speed of their scope's acquisition system as well as its memory depth and number of bits. The scope's maximum sampling speed does not apply to all sweep speeds, only memory depth and number of bits applies to all sweep speeds. The scope's maximum sampling speed applies only to its fastest sweep speeds.

The complexity of the digital scope results from the problem of having to sample the input. There is more to be considered than Nyquist's Sampling Theorem in the operation of a digital scope. For example, how does the scope's maximum sampling rate relate to the smallest time interval that the scope can capture and display? A scope that samples at  $100 \text{ MSA s}^{-1}$  takes a sample every 10 ns; therefore, in principle, it cannot display any event that is less than 10 ns wide because that event will fall between the samples. In practice, however, this limit can — under certain circumstances — be extended. If the scope is operating in an "equivalent time" or "random repetitive" mode and if the signal is repetitive, even if very

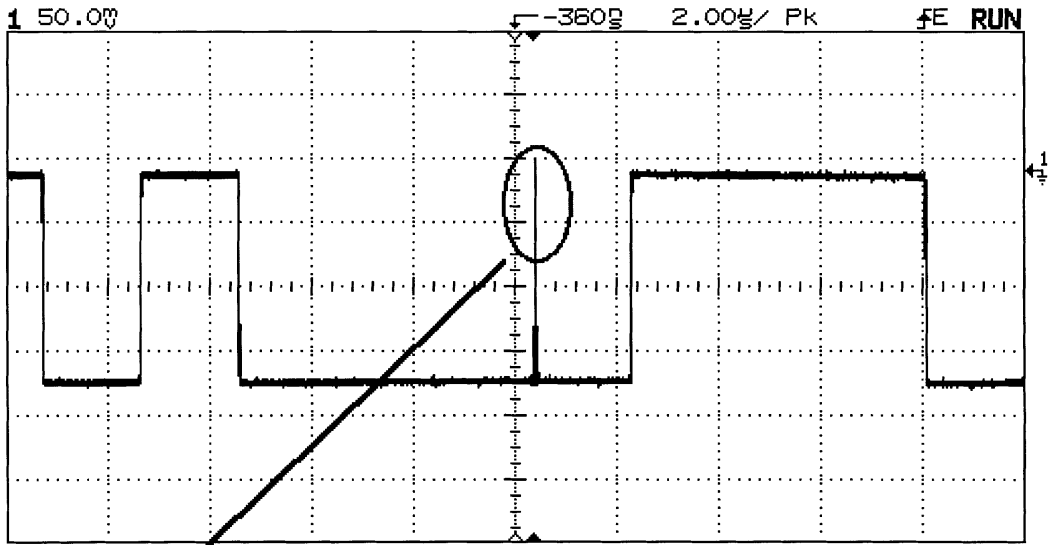

48 ns wide glitch at a 15 Hz rate

(a)

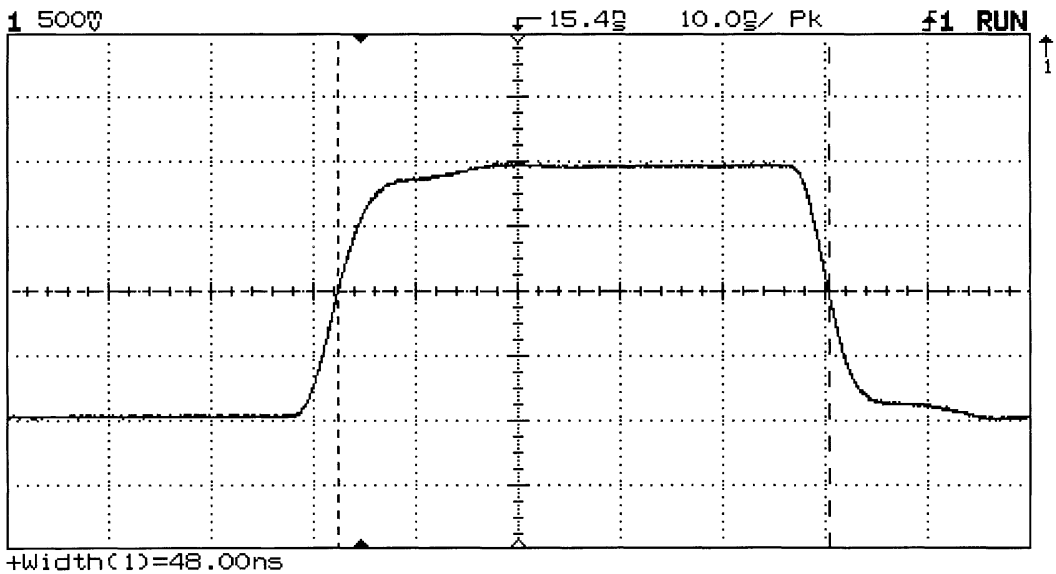

(b)

**FIGURE 37.26** An infrequently occurring event as displayed on a digital oscilloscope with random repetitive sampling. (a): the event embedded in a pulse train. (b): shows the same event at a faster sweep speed. The fact that the waveform baseline is unbroken under the narrow pulse indicates that it does not occur in every sweep. The width of this pulse is less than half the scope's sampling period in (b). Both traces are from a Hewlett Packard model 54603B dual channel 60-MHz scope.

infrequently, the scope will be able to capture any event that is within its vertical system bandwidth. [Figure 37.26](#) shows an infrequently occurring pulse that is 25 ns wide embedded into a data stream being captured and displayed on an oscilloscope with a maximum sampling speed of  $20 \text{ MSA s}^{-1}$  (sampling interval of 50 ns). [Figure 37.26\(b\)](#) shows this pulse at a faster sweep speed. An analog scope would produce



a similar display of this event, with the infrequent event being displayed at a lower intensity than the rest of the trace. Notice that the infrequent event does not break the baseline of the trace.

The correct mental model of the digital scope's ability to capture signals needs to be based on the scope's bandwidth, operating modes, and timing resolution. It is the timing resolution that tells the operator how closely spaced the samples can be in the scope's data record.

The most common flaw in many mental models of the operation of a digital scope is related to its maximum sampling speed specification. As noted, the maximum sampling speed specification applies only to the scope's fastest sweep speeds. Some scope manufacturers will use a multiplex A/D system that operates at its maximum sampling speed only in single-channel mode. The scope's memory depth determines its sampling speed at the sweep speed being used for any specific measurement. The scope's memory depth is always equal to the scope's horizontal full-scale setting. For scopes with no off-screen memory, this is  $10\times$  the time base setting. If the scope has off-screen memory, this must be taken into account. For example, assume that one has two scopes with a maximum sampling speed of  $100 \text{ MSA s}^{-1}$ . One scope has a memory depth of 5 K points and the other only 1 K. At a sweep speed of  $1 \mu\text{s}$  per division, both scopes will be able to store data into their memory at their full sampling speed, and each will be storing 100 data points per division, for a total of 1000 data points being stored. The scope with the 5 K memory will have a data point in one of every 5 memory locations, and the scope with the 1 K memory will have a data point in every memory location. If one reduces the sweep speed to  $5 \mu\text{s}/\text{div}$ , the deeper memory scope will now fill every one of its memory locations with data points separated by 10 ns. The scope with only 1 K of memory would produce a display only 2 divisions wide if its sampling speed is not reduced. Scope designers believe that scope users expect to see a full-length sweep at every sweep speed. Therefore, the 1 K scope must reduce its sampling speed to one sample every 50 ns, or  $20 \text{ MSA s}^{-1}$ , to be able to fill its memory with a full sweep width of data. This 5:1 ratio of sampling speeds between these two scopes will be maintained as their time bases are set to longer and longer sweeps. For example, at  $1 \text{ s}/\text{div}$ , the 5 K scope will be sampling at 500 samples per second, while the 1 K scope will be sampling at only 100 samples per second. One can determine a scope's sampling speed for any specific time base setting from Equation 37.51.

$$S \left( \text{samples/second} \right) = \frac{\text{memory depth (samples)}}{\text{full-scale time base (seconds)}}, \quad (37.51)$$

or the scope's maximum sampling speed, whichever is less

One must look closely at the application to determine if a specific scope is best suited to that application. As a rule, the deeper the memory, the faster the scope will be able to sample the signal at any given time base setting. Memory depth is not free. High-speed memory required to be able to store the data out of the scope's A/D is costly, and deeper memory takes longer to fill, thus reducing the scope's display update rate. Most scopes that provide memory depths of 20 K or more will also give the user a memory depth selection control so that the user can select between fast and deep. (In 1996, Hewlett Packard Co. introduced two scopes based on an acquisition technology known as MegaZoom (TM) [10] that removes the need for a memory depth control.) A correct mental model for the sampling speed of a digital scope is based on Equation 37.51 and not just on the scope's maximum performance specifications.

Some digital oscilloscopes offer a special sampling mode known as *peak detection*. Peak detection is a special mode that has the effect of extending the scope's sampling speed to longer time records. This special mode can reduce the possibility of an aliased display. The performance of this special mode is specified as the minimum pulse width that the peak detection system can capture. There are several peak detection systems being used by the various manufacturers. Tektronix has an analog-based peak detection system in some of its models, while Hewlett Packard has a digital system in all of its models. Both systems perform as advertised, and they should be evaluated in the lab to see which system best meets one's needs. There is a down side to peak detection systems and that is that they display high-frequency noise

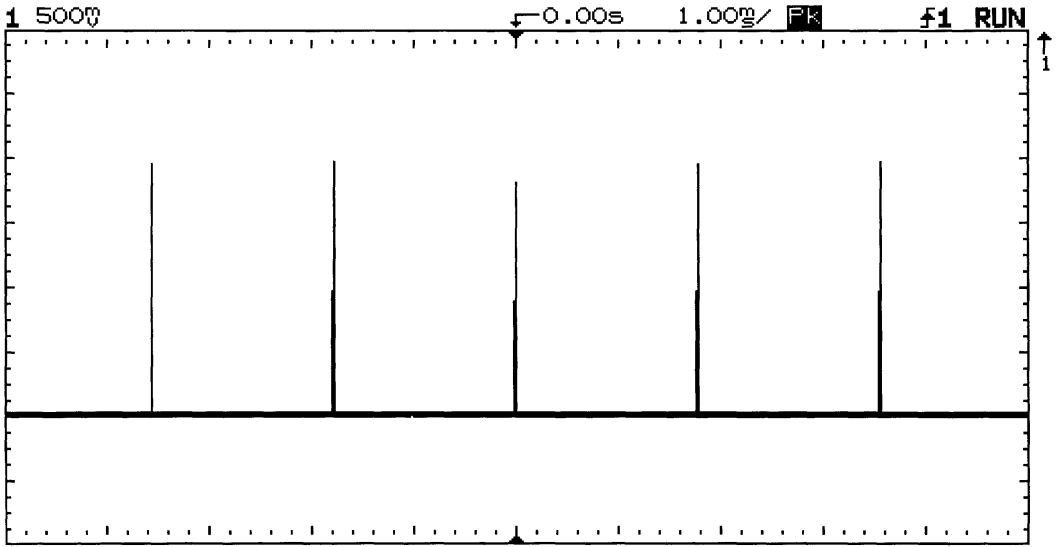

(a)

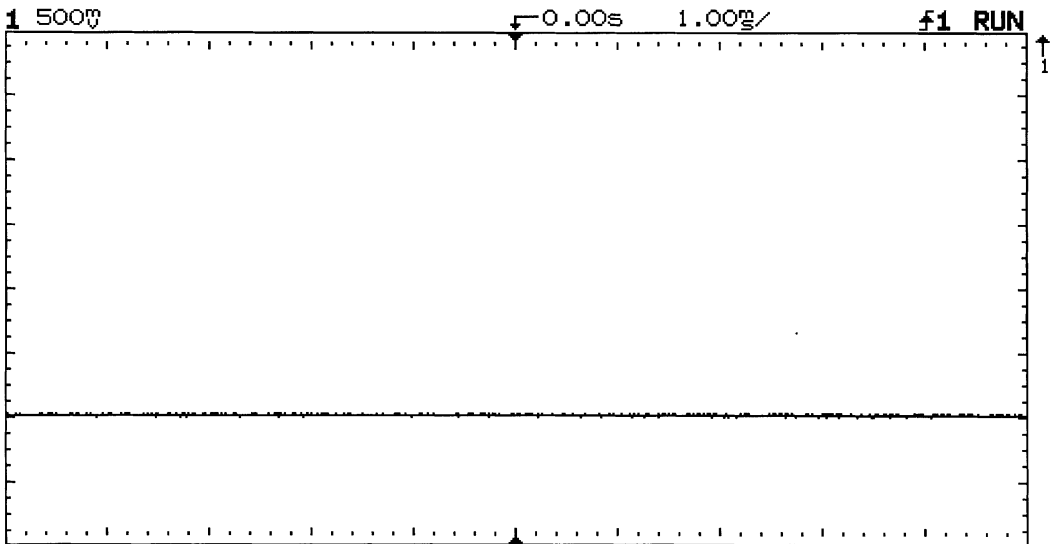

(b)

**FIGURE 37.27** Peak detection. This special mode has the effect of increasing the scope's sampling speed at time base settings where it would be decimated. In operation, each memory location contains either the maximum or minimum value of the waveform at that location in time. (a): a series of 300-ns wide pulses being captured at a slow sweep speed; (b): the same setup with peak detection disabled. These narrow pulses would appear as intermittent pulses if the scope could be seen in operation with peak detection disabled.

that might not be within the bandwidth of the system under test. [Figure 37.27](#) shows a narrow pulse being captured by peak detection and being missed when the peak detection is off.

What effect does display dead-time have on the oscilloscope's voltage measurement capabilities? Display dead-time applies to both analog and digital oscilloscopes, and it is that time when the oscilloscope is not capturing the input signal. This is also a very important consideration in the operation of a digital scope because it determines the scope's ability to respond to front-panel control commands and to follow

changing waveforms. A digital scope that produces an incorrect display of an amplitude-modulated signal is not following this rapidly changing signal because its display update rate is too low. Sampling speed is not related to display update rate or dead-time. Display dead-time is a function of the scope's ability to process the waveform data from its A/D and plot it on the display. Every major oscilloscope manufacturer has been working on this problem. Tektronix offers a special mode on some of its products known as InstaVu (TM) [4]. This special mode allows these scopes to process up to 400,000 waveforms per second to their display. Hewlett Packard has developed a multiple parallel processor technology [5] in the HP 54600 series of benchtop scopes that provides a high-speed, low dead-time display in a low-cost instrument. These instruments can plot 1,500,000 points per second to their display and they have no dead-time at their slower sweep speeds. LeCroy has been applying the Power PC as an embedded processor for its scopes to increase display throughput. There are other special modes being produced by other vendors, so be sure to understand what these can do before selecting an oscilloscope. [Figure 37.28](#) shows the effect of display update rate on a rapidly changing waveform. An amplitude-modulated signal is displayed with a high-speed display and with the display speed reduced by the use of hold-off.

## Triggering

The trigger of the oscilloscope has no direct effect on the scope's ability to measure a voltage except that the trigger does enable the oscilloscope to produce a stable display of the voltage of interest. Ref. [6] presents a thorough discussion of this subject.

## Conclusion

The mental model that oscilloscope users have created in their minds of the oscilloscope's operation can be helpful in reducing measurement errors. If the operator's mental model is based on the following facts, measurement errors can be minimized:

- Oscilloscopes have a frequency response that affects measurement accuracy.
- Digital scopes are more accurate than analog scopes.
- Analog scopes do not have continuous displays.
- Oscilloscope accuracy specifications always contain a percent of full-scale term.
- Measurements should be made at the largest possible deflection in order to minimize errors.
- Maximum sampling speed is available only at the scope's fastest sweep speeds.
- Deeper memory depth allows faster sampling at more sweep speeds.
- All digital scopes can produce aliases, some more than others.
- Display dead-time is an important characteristic of digital scopes that is often not specified.
- Display dead-time affects measurement accuracy because it can cause a distorted display.
- The scope with the highest maximum sampling speed specification might not be the most accurate or have the lowest display dead-time.
- The operator must have some knowledge of the signals being measured to be able to make the best possible measurements.

The person who has the mental model of the oscilloscope that takes these factors into account will be able to purchase the scope that is best suited to his/her application and not spend too much money on unnecessary performance. In addition, that person will be able to make measurements that are up to the full accuracy capabilities of the scope.

## Selecting the Oscilloscope

There are ten points to consider when selecting an oscilloscope. This author has published a thorough discussion of these points [7] and they are summarized as follows:

1. **Analog or Digital?** There are a few places where the analog scope might be the best choice, and the reader can make an informed selection based on the information presented here.

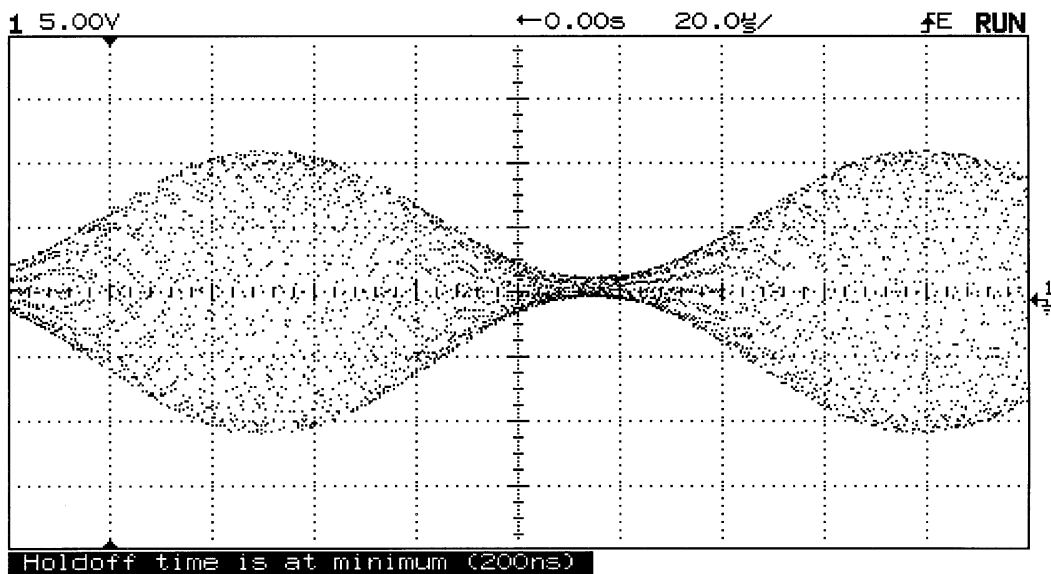

(a)

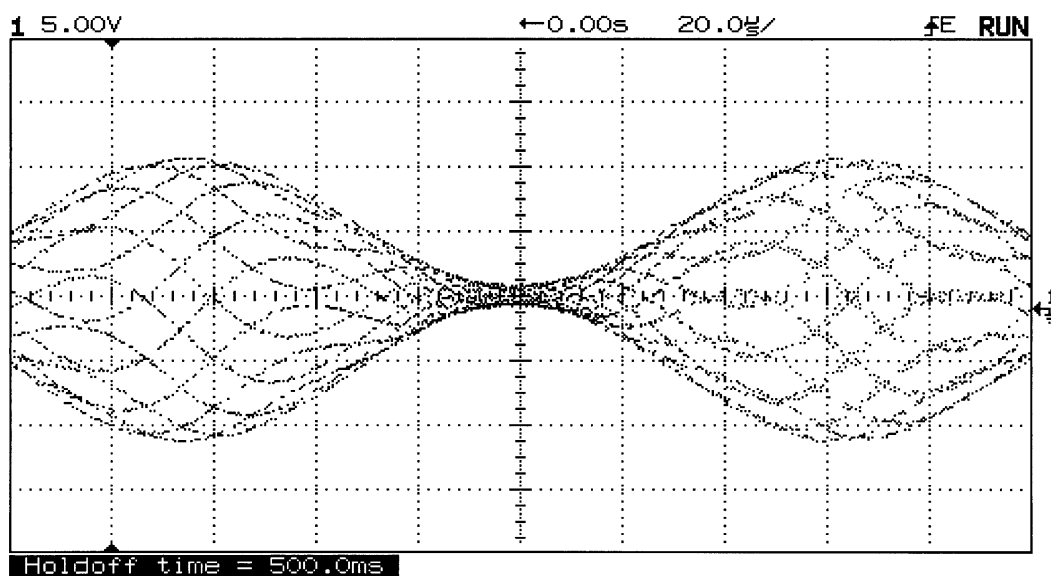

(b)

**FIGURE 37.28** Display dead-time. The time that an oscilloscope is blind to the input signal has an effect on the scope's ability to correctly display rapidly changing signals. (a): an amplitude-modulated signal with a high-speed display; (b): the same signal with the dead-time increased by use of hold-off.

2. **How much bandwidth?** This is a place where the person selecting an oscilloscope can save money by not purchasing more bandwidth than is needed. When analog oscilloscopes were the only choice, many people were forced to purchase more bandwidth than they needed because they needed to view infrequent or low repetition signals. High bandwidth analog scopes had brighter CRTs so that they were able to display high-frequency signals at very fast time base settings. At a sweep speed of 5 ns/div, the phosphor is being energized by the electron beam for 50 ns, so the electron beam had

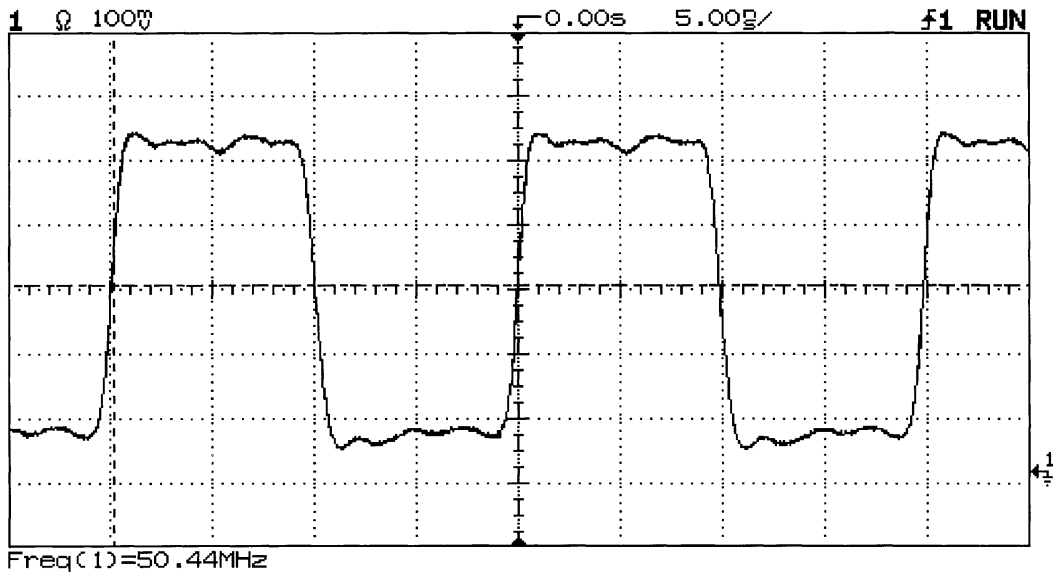

(a) BW = 500 Mhz

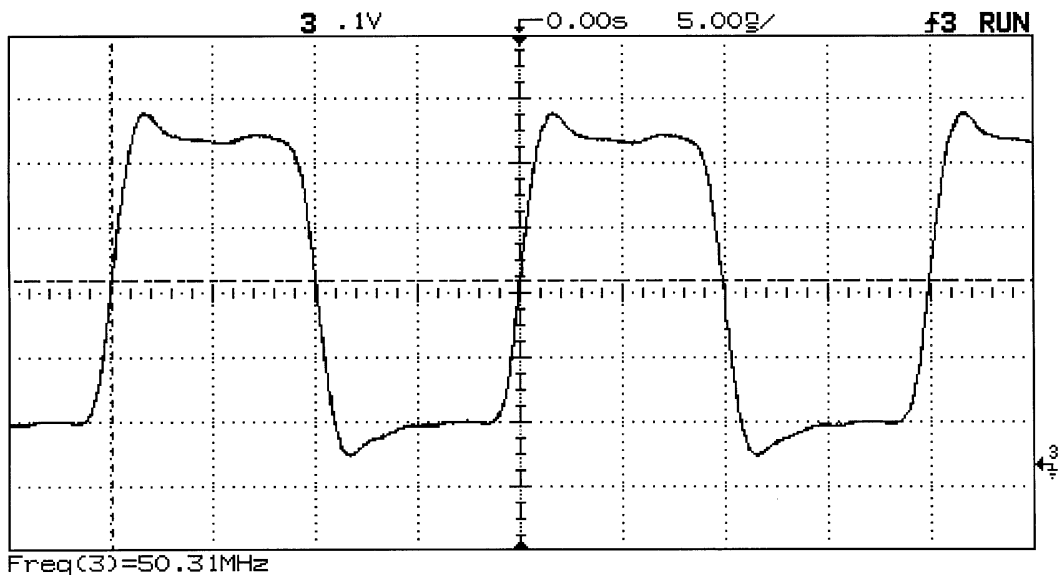

(b) BW = 250 Mhz

**FIGURE 37.29** The effect of the scope's bandwidth is shown in this set of waveforms. The same 50-MHz square wave is shown as it was displayed on scopes of 500 MHz in Figure 37.28(a) all the way down to 20 MHz in Figure 37.29(e). Notice that the 100-MHz scope produced a usable display although it was missing the high-frequency details of the 500-MHz display. The reason that the 100-MHz scope looks so good is the fact that its bandwidth is slightly greater than 100 MHz. This performance, which is not specified on any data sheet, is something to look for in any evaluation.

to be very high energy to produce a visible trace. This situation does not apply to digital scopes. Now, one needs to be concerned only with the bandwidth required to make the measurement.

Figure 37.29 shows the effect of oscilloscope bandwidth on the display of a 50-MHz square wave.

The oscilloscope's bandwidth should be  $>2\times$  the fundamental highest frequency signal to be measured.

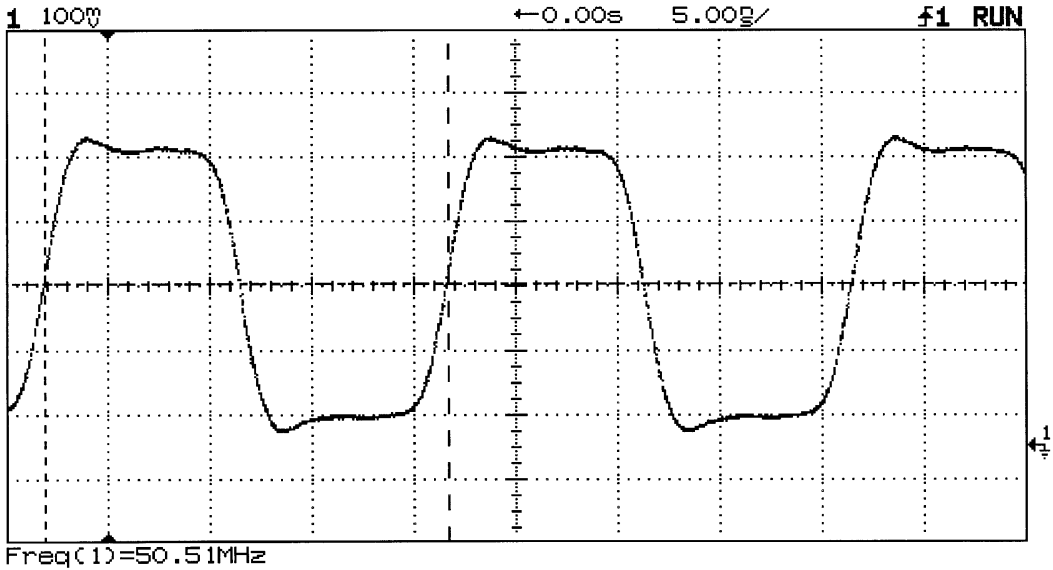

(c) BW = 100 MHz

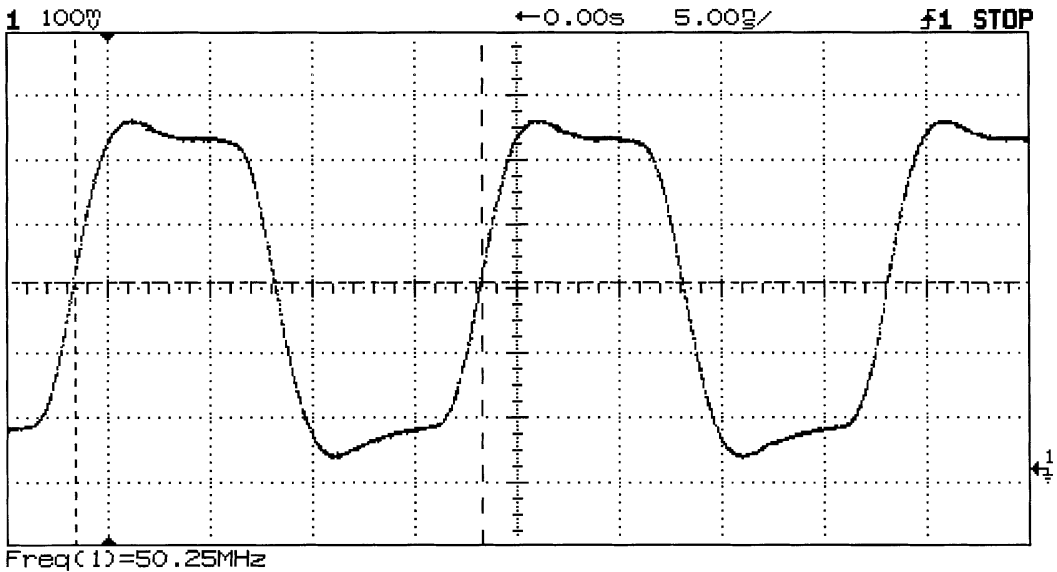

(d) BW = 60 MHz

FIGURE 37.29 (continued)

The bandwidth of the scope's vertical system can affect the scope's ability to correctly display narrow pulses and to make time interval measurements. Because of the scope's Gaussian frequency response, one can determine its ability to correctly display a transient event in terms of risetime with Equation 37.52.

$$t_r = 0.35/BW \quad (37.52)$$

Therefore, a 100-MHz scope will have a rise time of 3.5 ns. This means that if the scope were to have a signal at its input with zero rise time edges, it would be displayed with 3.5-ns edges.

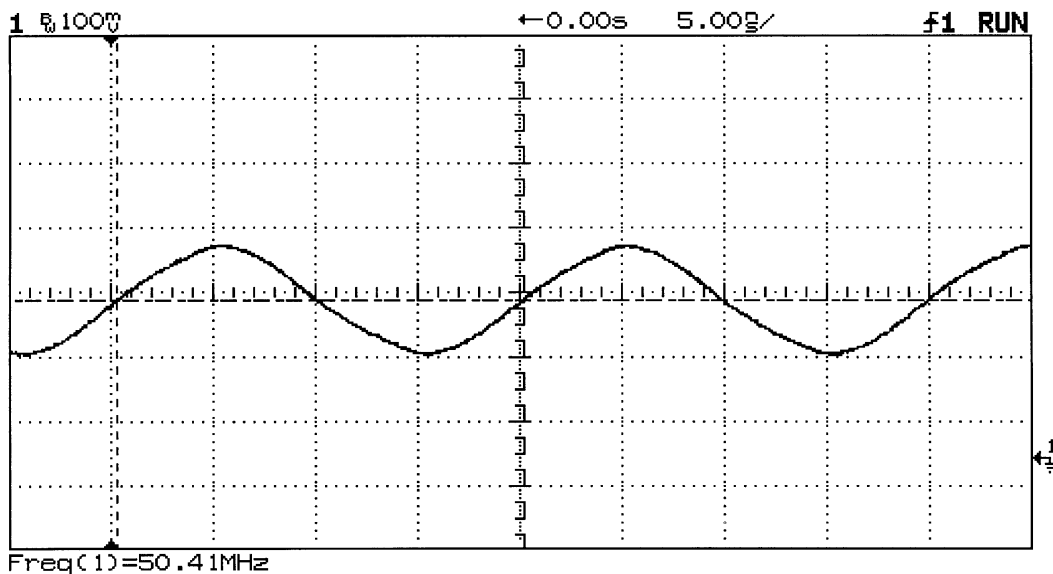

(e) BW = 20 Mhz

FIGURE 37.29 (continued)

This will affect the scope's measurements in two ways. First is narrow pulses. Figure 37.30 shows the same 5-ns wide pulse being displayed on oscilloscopes of 500 MHz and 60 MHz bandwidths, and the effect of the lower bandwidth on this event that is closest to the risetime of the slower scope is apparent.

The second is fast time interval measurements. A measurement of signal risetime is an example. The observed risetime on the scope's display is according to Equation 37.53.

$$t_{\text{observed}} = \left( t_{\text{signal}}^2 + t_{\text{scope}}^2 \right)^{1/2} \quad (37.53)$$

If a 10-ns risetime were to be measured with a 100-MHz scope, one would obtain a measurement of 10.6 ns based on Equation 37.53. The scope would have made this measurement with a 6% reading error before any other factors, such as time base accuracy, are considered.

The scope's risetime should be at least no more than 1/5 of the shortest time interval to be measured. For time interval measurements, this should be >1/10.

3. **How many channels?** Most oscilloscopes in use today are dual-channel models. In addition, there are models described as being 2+2 and four channels. This is one time where 2+2 is not equal to 4. The 2+2 models have limited features on two of their channels and cost less than 4-channel models. Most oscilloscope suppliers will hold the 4-channel description only for models with four full-featured channels, but user should be sure to check that the model under consideration so as to be sure if it is a 4- or 2+2 model. Either of the four channel classes is useful for applications involving the testing and development of digital-based systems where the relationship of several signals must be observed.

Hewlett Packard introduced a new class of oscilloscopes that is tailored for the applications involving both analog and digital technologies, or mixed-signal systems. The mixed signal oscilloscope (MSO) [4] provides two scope channels and 16 logic channels so that it can display both the analog and digital operation of a mixed-signal system on its display.

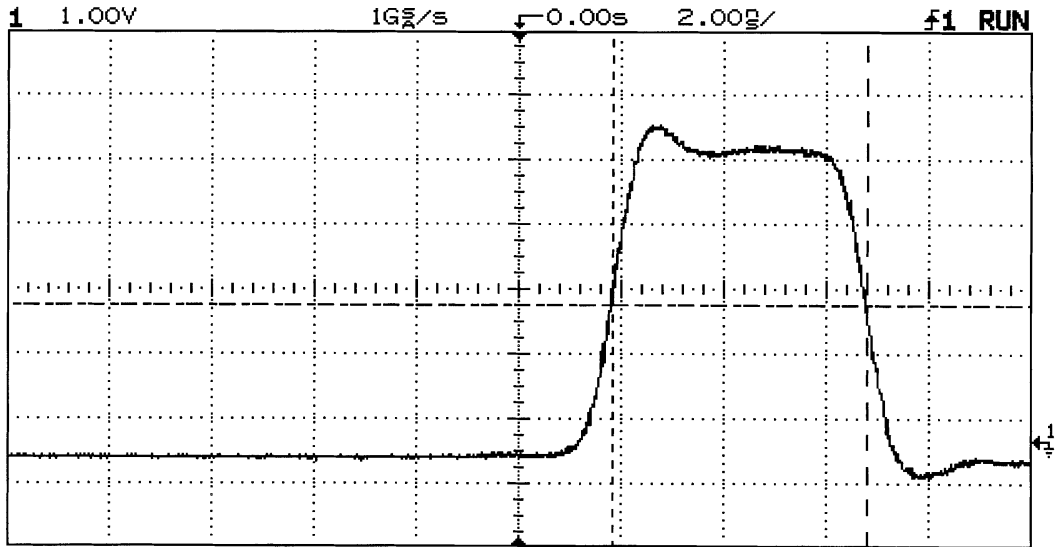

(a)

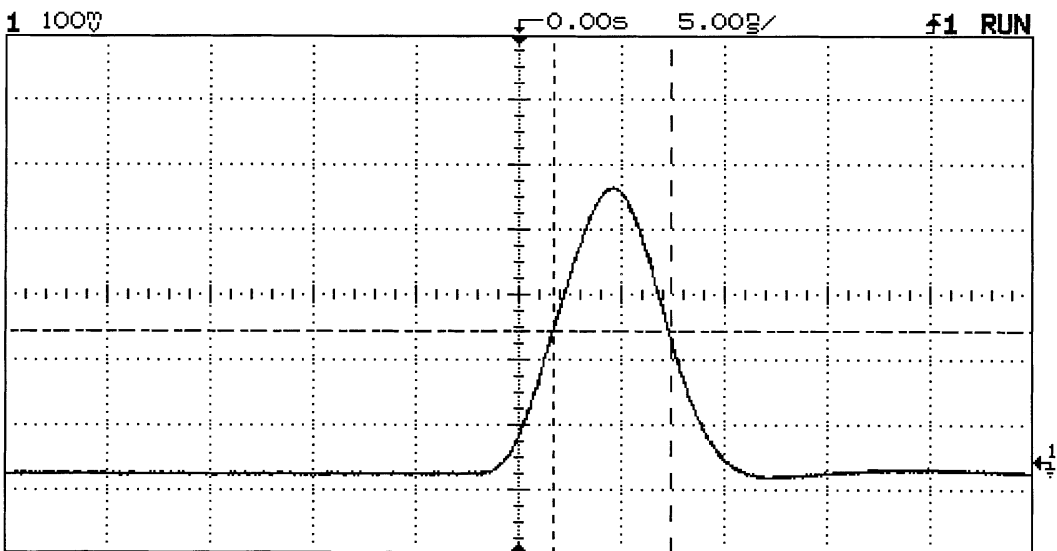

(b)

**FIGURE 37.30** Bandwidth and narrow events. (a): a 5-ns wide pulse as displayed on a 500-MHz scope; (b): the same pulse displayed on a 60-MHz scope. The 60-MHz scope has a risetime of 5.8 ns, which is longer than the pulse width. This results in the pulse shape being incorrectly displayed and its amplitude being in error.

4. **What sampling speed?** Do not simply pick the scope with the highest banner specification. One needs to ask, what is the sampling speed at the sweep speeds that my application is most likely to require? As observed in Equation 37.51 the scope's sampling speed is a function of memory depth and full-scale time base setting. If waveforms are mostly repetitive, one can save a lot of money by selecting an oscilloscope that provides equivalent time or random repetitive sampling.
5. **How much memory?** As previously discussed, memory depth and sampling speed are related. The memory depth required depends on the time span needed to measure and the time resolution required. The longer the time span to be captured and the finer the resolution required, the more



memory one will need. High-speed waveform memory is expensive. It takes time to process a longer memory, so the display will have more dead time in a long memory scope than a shallow memory model. All the suppliers of deep memory scopes provide a memory depth control. They provide this control so that the user can choose between a high-speed display and deep memory for the application at hand. Hewlett Packard introduced MegaZoom (TM) technology [3] in 1996; it produces a high-speed low dead-time display with deep memory all the time.

6. **Triggering?** All scope manufacturers are adding new triggering features to their products. These features are important because they allow for triggering on very specific events. This can be a valuable troubleshooting tool because it will let the user prove whether a suspected condition exists or not. Extra triggering features add complexity to the scope's user interface; so be sure to try them out to make sure that they can be applied.
7. **Trustworthy display?** Three factors critically affect a scope's ability to display the unknown and complex signals that are encountered in oscilloscope applications. If the user loses confidence in the scope's ability to correctly display what is going on at its probe tip, productivity will take a real hit. These are display update rate, dead-time, and aliasing.

Because all digital scopes operate on sampled data, they are subject to aliasing. An alias is a false reconstruction of the signal caused by under-sampling the original. An alias will always be displayed as a lower frequency than the actual signal. Some vendors employ proprietary techniques to minimize the likelihood of this problem occurring. Be sure to test any scope being considered for purchase on your worst-case signal to see if it produces a correct or aliased display. Do not simply test it with a single-shot signal that will be captured at the scope's fastest sweep speed because this will fail to test the scope's ability to correctly display signals that require slower sweep speeds.

8. **Analysis functions?** Digital oscilloscopes with their embedded microprocessors have the ability to perform mathematical operations that can give additional insight into waveforms. These operations often include addition, subtraction, multiplication, integration, and differentiation. An FFT can be a powerful tool, but do not be misled into thinking it is a replacement for a spectrum analyzer. Be sure to check the implementation of these features in any scope being considered. For example, does the FFT provide a selection of window functions? Are these analysis functions implemented with a control system that only their designer could apply?
9. **Computer I/O?** Most of the digital scopes on the market today can be interfaced to a PC. Most of the scope manufacturers also provide some software that simplifies the task of making the scope and PC work together. Trace images can be incorporated into documents as either PCX or TIF files. Waveform data can be transferred to spreadsheet applications for additional analysis. Some scope models are supplied with a disk drive that can store either waveform data or trace images.
10. **Try it out?** Now one has the information to narrow oscilloscope selection to a few models based on bandwidth, sampling speed, memory depth, and budget requirements. Contact the scope vendors (Table 37.3) and ask for an evaluation unit. While the evaluation unit is in the lab, look for the following characteristics:

- Control panel responsiveness: Does the scope respond quickly to inputs or does it have to think about it for a while?
- Control panel layout: Are the various functions clearly labeled? Does the user have to refer to the manual even for simple things?
- Display speed: Turn on a couple of automatic measurements and check that the display speed remains fast enough to follow changing signals.
- Aliasing: Does the scope produce an alias when the time base is reduced from fast to slow sweep speeds? How does the display look for the toughest signal?

The oscilloscope is undergoing a period of rapid change. The major manufacturers of oscilloscopes are no longer producing analog models and the digital models are evolving rapidly. There is confusion in the oscilloscope marketplace because of the rapid pace of this change. Hopefully, this discussion will prove valuable to the user in selecting and applying oscilloscopes in the lab in the years to come.

**TABLE 37.3** Major Suppliers of Oscilloscopes and their Web Addresses

Vendor	Description	Web address
B&K Precision 6460 W. Cortland St. Chicago, IL 60635	Analog and digital scopes and Metrix scopes in France	<a href="http://bkprecision.com">http://bkprecision.com</a>
Boonton Electronics Corp. 25 Estmans Road P.O. Box 465 Parsippany, NJ 07054-0465	U.S. importer for Metrix analog, mixed analog, and digital scopes from France	<a href="http://www.boonton.com">http://www.boonton.com</a>
Fluke P.O. Box 9090 Everett, WA 98206-9090	Hand-held, battery-powered scopes (ScopeMeter), analog scopes, and CombiScopes(R)	<a href="http://www.fluke.com">http://www.fluke.com</a>
Gould Roebuck Road, Hainault, Ilford, Essex IG6 3UE, England	200-MHz DSO products	<a href="http://www.gould.co.uk">http://www.gould.co.uk</a>
Hewlett Packard Co. Test & Measurement Mail Stop 51LSJ P.O. Box 58199 Santa Clara, CA 95052-9952	A broad line of oscilloscopes and the Mixed Signal oscilloscope for technical professionals	<a href="http://www.tmo.hp.com/tmo/pia">http://www.tmo.hp.com/tmo/pia</a> search on "oscilloscopes"
LeCroy Corp. 700 Chestnut Ridge Road Chestnut Ridge, NY 10977	Deep memory oscilloscopes for the lab	<a href="http://www.lecroy.com">http://www.lecroy.com</a>
Tektronix Inc. Corporate Offices 26600 SW Parkway P.O. Box 1000 Watsonville, OR 97070-1000	The broad line oscilloscope supplier with products ranging from hand-held to high-performance lab scopes	<a href="http://www.tek.com/measurement">http://www.tek.com/measurement</a> search on "oscilloscopes"
Yokogawa Corp. of America Corporate offices Newnan, GA 1-800-258-2552	Digital oscilloscopes for the lab	<a href="http://www.yca.com">http://www.yca.com</a>

## References

1. A. DeVibiss, Oscilloscopes, in C. F. Coombs, Jr. (ed.), *Electronic Instrument Handbook*, 2nd ed., New York, McGraw-Hill, 1995.
2. R. A. Witte, A family of instruments for testing mixed-signal circuits and systems, *Hewlett Packard J.*, April 1996, Hewlett Packard Co., Palo Alto, CA.
3. M.S. Holcomb, S.O. Hall, W.S. Tustin, P.J. Burkart, and S.D. Roach, Design of a mixed signal oscilloscope, *Hewlett Packard J.*, April 1996, Hewlett Packard Co., Palo Alto, CA.
4. InstaVu acquisition mode, *Tektronix Measurement Products Catalog*, Tektronix Inc., Beaverton, OR, 1996, 69.
5. M.S. Holcomb and D.P. Timm, A high-throughput acquisition architecture for a 100 MHz digitizing oscilloscope, *Hewlett Packard J.*, February 1992, Hewlett Packard Co., Palo Alto, CA.
6. R.A. Witte, *Electronic Test Instruments, Theory and Applications*, Englewood Cliffs, NJ, Prentice-Hall, 1993.
7. J. Murphy, Ten points to ponder in picking an oscilloscope, *IEEE Spectrum*, 33(7), 69-77, 1996.

## 37.3 Inductive and Capacitive Voltage Measurement

*Cipriano Bartoletti, Luca Podestà, and Giancarlo Sacerdoti*

This chapter section addresses electrical measurements where the voltage range to be measured is very large — from  $10^{-10}$  V to  $10^7$  V. The waveform can be continuous, periodic, or impulsive. If it is periodic, the spectrum components can vary for different situations, and within the same electric power network there may be subharmonic components. In impulsive voltage measurement, it is often important to get maximum value, pulse length, etc. Capacitive and inductive voltage sensors are mainly utilized in low-frequency electric measurements.

### Capacitive Sensors

The voltage to be measured can be reduced by means of capacitive dividers (Figure 37.31). Capacitive dividers are affected by temperature and frequency and therefore are not important, at least in Europe. Capacitive sensors detect voltage by different methods:

1. Electrostatic force (or torque)
2. Kerr or Pockels effect
3. Josephson effect
4. Transparency through a liquid crystal device
5. Change in refractive index of the optic fiber or in light pipe

1. The relations that rule the listed capacitive voltage sensors are reported below. The force between two electrodes is (Figure 37.32):

$$F = \epsilon_0 \frac{S}{d} (V_1 - V_2)^2 \quad (37.54)$$

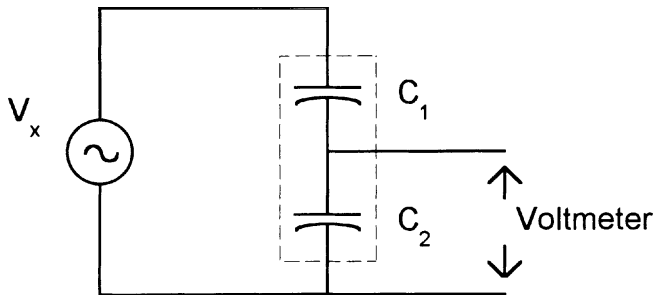

**FIGURE 37.31** Schematic arrangement of a capacitive divider.

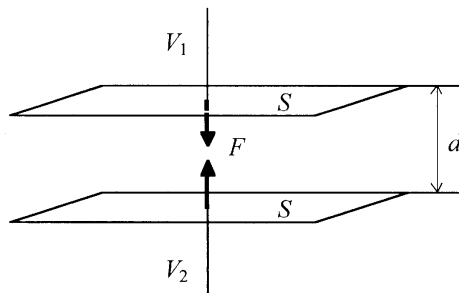

**FIGURE 37.32** Force between two electrodes with an applied voltage.

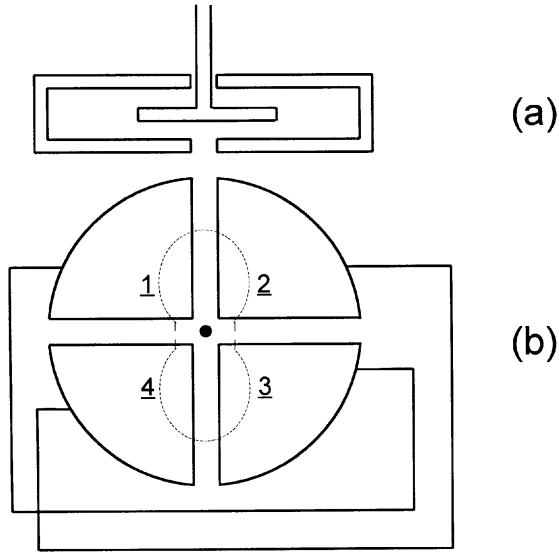

**FIGURE 37.33** Scheme of an electrostatic voltmeter. (a) lateral view, (b) top view: (1), (2), (3), (4) are the static electrodes; the moving vane is shown in transparency.

where  $\epsilon_0$  = Dielectric constant  
 $S$  = Area of the electrode  
 $d$  = Distance  
 $V_1, V_2$  = Potentials of the electrodes

The *torque* between electrostatic voltmeter quadrants (Figure 37.33) is given by:

$$T = \frac{1}{2} \frac{\partial C}{\partial \theta} (V_1 - V_2)^2 \quad (37.55)$$

where  $C$  = Capacitance  
 $\theta$  = Angle between electrodes

To get the torque from the rate of change (derivative) of electrostatic energy vs. the angle is easy. Obtaining the torque by mapping the electric field is difficult and requires long and complex field computing.

2. The rotation of the polarization plane of a light beam passing through a KDP crystal under the influence of an electric field (*Pockels effect*) is expressed by (Figure 37.34):

$$\theta = k_p I (V_1 - V_2) \quad (37.56)$$

where  $k_p$  = Electro-optic constant  
 $I$  = Length of crystal

One obtains a rotation of  $\pi/2$  by applying a voltage of the order of 1 kV to a KDP crystal of a few centimeters in length.

If a light beam passes through a light pipe that performs the *Kerr effect*, one observes a quadratic dependence of the rotation vs.  $V$ .

$$\theta \equiv kE^2 \equiv k'V^2 \quad (37.57)$$

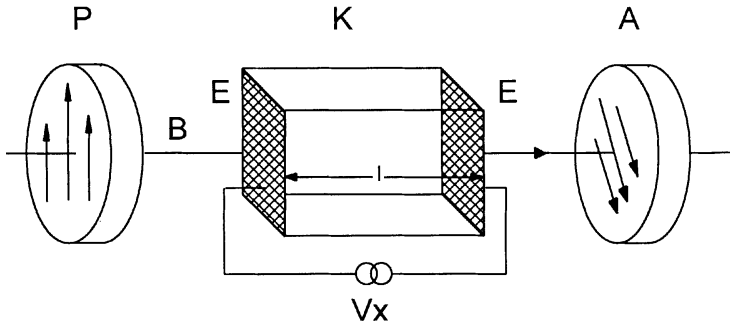

**FIGURE 37.34** Scheme of an electrooptic KDP device. The parts are labeled as: (B) a light beam, (P) a polarizer, (A) an analyzer, (K) a KDP crystal, with the voltage to be measured  $V_x$  applied to its (E) transparent electrodes.

3. The *Josephson effect* consists of translation of a voltage into a periodical signal of a certain frequency, carried out by a special capacitive sensor. There is an array of  $N$  layers of Josephson superconducting junctions; the frequency of emitted signal, when a voltage  $V$  is applied, is given by:

$$v = \frac{2eV}{Nh} \quad (37.58)$$

4. The *transparency* of a liquid crystal device depends on the difference of potential applied. There are liquid crystal devices working in transmission or in reflection. A change in transparency is obtained when a difference of potential of a few volts is applied.

5. The *change in refractive index* due to the presence of an electric field can be detected by:

- Interferometric methods (where the velocity of light is equal to  $c/n$ )
- Change in light intensity in a beam passing through an optical wave guide device like [Li-Nb](#) (Figure 37.35).

By means of method 1, many kinds of instruments (voltmeters) can be realized. Methods 2 through 5 are used in research laboratories but are not yet used in industrial measurements.

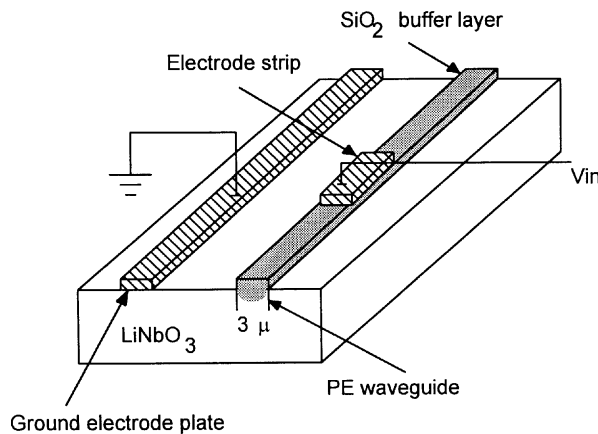

**FIGURE 37.35** Li-Nb optical wave guide device.

## Inductive Sensors

### Voltage Transformers (VTs)

Voltage transformers have two different tasks:

- Reduction in voltage values for meeting the range of normal measuring instruments or protection relays
- Insulation of the measuring circuit from power circuits (necessary when voltage values are over 600 V)

Voltage transformers are composed of two windings — one primary and one secondary winding. The primary winding must be connected to power circuits; the secondary to measuring or protection circuits. Electrically, these two windings are insulated but are connected magnetically by the core.

One can define:

$$\text{Nominal ratio} = K_n = \frac{V_{1n}}{V_{2n}} \quad (37.59)$$

as the ratio between the magnitude of primary and secondary rated voltages.

$$\text{Actual ratio} = K = \frac{V_1}{V_2} \quad (37.60)$$

as the ratio between the magnitudes of primary and secondary actual voltages.

*Burden* is the value of the apparent power (normally at  $\cos\phi = 0.8$ ) that can be provided on the secondary circuit (instruments plus connecting cables).

Burden limits the maximum value of secondary current and then the minimum value of impedance of the secondary circuit is:

$$Z_{\min} = \frac{V_{2n}^2}{A_n} \quad (37.61)$$

where  $A_n = \text{VT burden}$

For example, if  $A_n = 25 \text{ VA}$  and  $V_{2n} = 100 \text{ V}$ , one obtains:

$$Z_{\min} = \frac{100}{0.25} = 400 \text{ W} \quad (37.62)$$

There are two kinds of errors:

1. *Ratio error* =  $h_{\%} = \frac{K_n - K}{K}$  (37.63)
2. *Angle error* = the phase displacement between the primary voltage and the secondary voltage (positive if the primary voltage lags the secondary one).

Voltage transformers are subdivided into accuracy classes related to the limits in ratio and angle error (according to [CEI](#) and [IEC](#) normative classes 0.1, 0.2, 0.5, 1, 3; see [Table 37.4](#)). To choose the voltage transformer needed, the following technical data must be followed:

**TABLE 37.4** Angle and Ratio Error Limit Table Accepted by CEI-IEC Standards

Class	Percentage voltage (ratio)	Phase displacement	
	error ( $\pm$ )	Minutes ( $\pm$ )	Centiradians ( $\pm$ )
0.1	0.1	5	0.15
0.2	0.2	10	0.3
0.5	0.5	20	0.6
1	1	40	1.2
3	3	—	—
3P	3	120	3.5
6P	6	240	7

- Primary and secondary voltage (rated transformation ratio). Normally, the secondary value is 100 V.
- Accuracy class and rated burden in VA: e.g., cl. 0.5 and  $A_n = 10$  VA.
- Rated working voltage and frequency
- Insulation voltage
- Voltage factor: the ratio between maximum operating voltage permitted and the rated voltage. The standard voltage factor is  $1.2 V_n$  (i.e., the actual primary voltage) for an unlimited period of time (with VT connected with phases), and is  $1.9 V_n$  for a period of 8 h for VT connected between phase and neutral.
- Thermal power is the maximum burden withstood by VT (errors excluded).

For extremely high voltage values, both capacitive dividers and voltage transformers are normally used, as shown in [Figure 37.36](#). The capacitive impedance must compensate for the effect of the transformer's internal inductive impedance at the working frequency.

**Other Methods**

The ac voltage inductive sensors act by interaction between a magnetic field (by an electromagnet excited by voltage to be measured) and the eddy current induced in an electroconductive disk, producing a force or a torque. This can be achieved by the scheme shown in [Figure 37.37](#). The weight of many parts of the indicator can be some tens of grams. The power absorbed is on the order of a few watts. The precision is not high, but it is possible to get these sensors or instruments as they are similar to the widely produced induction energy meters. They are quite robust and are priced between \$50 and \$100, but they are not widely used. The relation between torque and voltage is quadratic:

$$T = k_i V^2 \tag{37.64}$$

The proportionality factor  $k_i$  depends on magnet characteristics and disk geometry.

G.E.C., Landys & Gyr, A.B.B., Schlumberger, etc. are the major companies that furnish components and instruments measuring voltage by inductive and capacitive sensors.

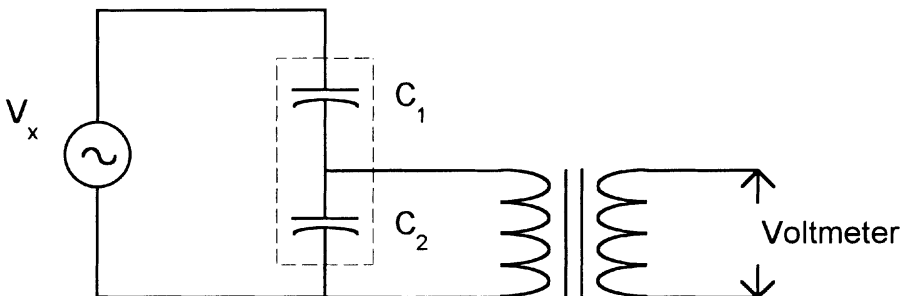

**FIGURE 37.36** Capacitive divider and voltage transformer device for extremely high voltage.

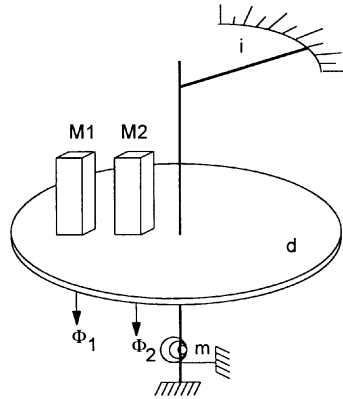

**FIGURE 37.37** Schematic inductive voltmeter. The parts are labeled as: (i) index, (d) metallic disk, (M1) and (M2) electromagnets, (m) spring, ( $\Phi_1$ ) and ( $\Phi_2$ ) generated fluxes.

## Defining Terms

**CEI:** Comitato Elettrotecnico Italiano.

**IEC:** International Electric Committee.

**KDP:** Potassium dihydrogen phosphate.

**Li-Nb:** ( $\text{LiNbO}_3$ ) lithium niobate.

## Further Information

J. Moeller and G. Rosenberger, Instrument transformers for HV Systems, Siemens Power Engineering III (1981) Special Issue, *High-Voltage Technology*.

G. Sacerdoti, O. Jappolo, and R. Paggi, *Misure Elettriche, Vol. I Strumenti*, Bologna, Zanichelli, 1994.

G. Zingales, *Metodi e Strumenti per le Misure Elettriche*, Bologna, UTET, 1976.